

Chilled Water & Plumbing Application

Valves Technical Guide



A History of Innovation

The Strength of Watts



"A tradition of quality and reliability, technology for the future"

The history of WATTS, dated back to 1874 in the United States, was always distinguished for its important and continuous contribute to the technological development of the market through the research and development of valves and related products that became a milestone in water and HVAC installations.

Our product range promotes the comfort and safety of people and the quality, conservation and control of water used in commercial, residential, industrial and municipal applications.

Watts does not limit to design products technologically advanced with premium quality. Watts implement a wide program of research and development, strictly integrated to market demand analysis and world development policies. This results I our research centers continuous effort to develop more efficient products and integrated solutions oriented to energy saving.

Watts has been chosen to supply the technological leading companies operating in the market as OEM (Operating Equipment Manufacturer) and as ODM (Original Design Manufacturer).

Watts, a synergic partner for the plumbing and HVAC application development since 1874.



a History of Innovation

<p>Watts Regulator Company founded by Joseph Watts in Lawrence, Massachusetts</p> 	<p>Received first of 18 patents</p>	<p>Burchard Home acquires Watts Regulator</p>	<p>Introduced T&P relief valve</p> 	<p>Opened first manufacturing facilities in Canada and England</p> 	<p>Relocated manufacturing facility from Lawrence, MA to Franklin, NH</p>	<p>Entered backflow market</p>	<p>Became a publicly traded company as Watts Industries</p> <p>WTS LISTED NYSE</p>	<p>Opened first manufacturing facility in China</p>	<p>Watts enters cast iron drain market</p>	<p>Watts hits \$1 billion sales mark</p>	<p>Entered stainless steel drains market</p>	<p>Expanded water safety presence in Europe</p>	<p>Expanded global footprint in New Zealand/Australia markets</p>	<p>Watts Works™ Learning Center opens in No. Andover, MA</p>	<p>Driving innovation with smart products & connected customers</p>	<p>Completed the acquisition of AVG</p>	<p>Completed the acquisition of The Detection Group</p>
1874	1880s	1918	1930s	1959/1960s	1970s	1986	1994	2006	2008	2011	2013	2014-2016	2015	2016	2018	2020	2021



MISSION

To improve comfort, safety, and quality of life for people around the world through our expertise in a wide range of water technologies.

To be the best in the eyes of our associates, customers, and shareholders.



A **WATTS** Brand



Founded 1949



Founded 1910



Founded 1982



Founded 1978



Founded 1965



Founded 1946



Founded 1924



Founded 1980



Founded 1974



Founded 1891



Founded 1989



Founded 1961



Founded 1956



Founded 1989



Founded 1956



Founded 1984



Founded 1987



Founded 1995



Founded 2006



Founded 1874



Watts Works Learning Program

Our state-of-the-art classrooms staffed with highly-qualified instructors will give you the hands-on training you need to better understand the right product for the job and how to use and maintain it.

Learn From The Best

- Understand how to choose the right product for a job
- Learn how to use and maintain our products correctly
- Achieve valuable accreditation
- Enhance proficiency with plumbing technologies and products
- Mix hands-on industrial lab experience with classroom instruction

In The Worldwide

- North Andover, MA
- St. Pauls, NC
- Woodland, CA
- Biassono, Italy
- Dubai, UAE
- Seoul, South Korea
- Ningbo, China

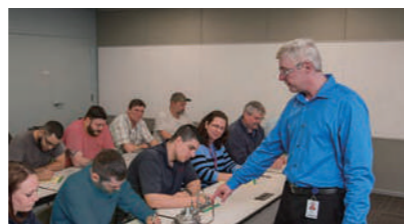

Product Select Tool



Product Selection Made Easy! Try our new online platform, to select products and quote them. Chilled water, Plumbing & Fire Protection packages.

Selexit



The Watts Selexit Configurator is an online tool designed to help designers and owners size, configure, and select products faster than ever before.

Design Stencils

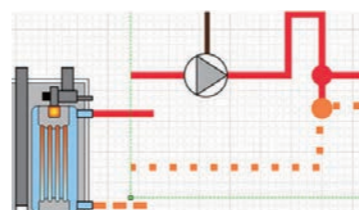

Create your own mechanical and electrical drawings in Microsoft Vision® using this free library of shapes from tekmar. Mechanical system shapes and electrical terminal layouts for controls and thermostats are included.

BIM & CAD Drawings



Preview and download 3D & 2D files including BIM files in a variety of industry formats including Revit, stp, dwg, jpeg, pdf, etc.

Product Cross-reference Tool



Use our cross-reference guides to match Watts model numbers with other manufactures model numbers.

WPRV Sizing Calculator



Use our water pressure reducing valve (WPRV) sizing calculator to properly size your valve to prevent noisy operation or premature valve failure.



Where We Installed – Iconic Projects



Atlantis Palm Jumeirah
Dubai, UAE



City Walk
Dubai, UAE



Habtoor City
Dubai, UAE



AL Masah Hotel New
Capital Cairo, Egypt



Galleria Mall,
Bahrain



Doha Festival
City, Qatar



Oman Convention Center
Oman, UAE

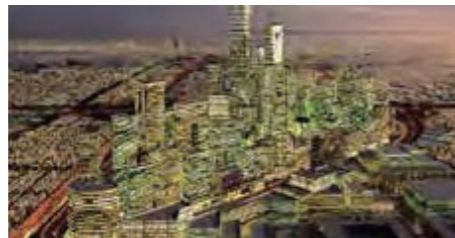

King Abdullah Financial
District, Saudi Arabia



Muscat International
Airport Muscat, Oman



Aramco Housing



Qatar Metro



Burj Khalifa Dubai,
UAE



Sang Housing,
KSA



Lusail Stadium,
Doha, Qatar



KFUPM, Saudi
Arabia

Where We Installed – Iconic Projects



Royal Atlantis,
Dubai, UAE



Al Thumama Stadium,
Doha, Qatar



Traditional Souq,
Abu Dhabi



Marsa Al Arab,
Dubai



Oberoi Skycity,
India



Sea World,
Abu Dhabi



Ajdhan Rise,
KSA



Ajyal Aramco Dhahyal
Housing, KSA



SANG Hospitals,
KSA

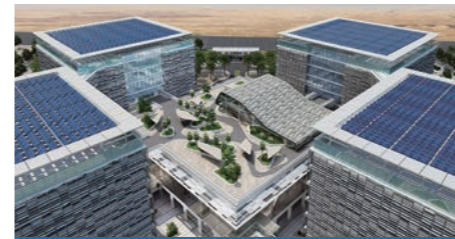

SEC Headquarters,
KSA



Jabal Omar
Development, KSA



Royal Commission MOD
Project C21, KSA



Sharma Hotels,
KSA



KAP 4 & 5 Project,
KSA

Project Reference List



KEY PROJECTS	COUNTRY	KEY PROJECTS	COUNTRY
CRESCENT Project	Azerbaijan	HYDE PARK CLUSTER 14	Egypt
Canal View Project	Bahrain	Jalala Mountain Project	Egypt
KHAYBAR Substation	Bahrain	Japanese University	Egypt
Mall of Dilmunia	Bahrain	Juhyna EGY food	Egypt
Marrassi Project	Bahrain	Lagoon Golden Coast	Egypt
Salmaniya Medical Center	Bahrain	Mall bein zayed MZ ,	Egypt
New Capital Project - all phases/segments	Egypt	Mall of Egypt	Egypt
5th District Conference Hall	Egypt	Marassi Project	Egypt
Administrative Control Building	Egypt	Medical MUP	Egypt
Al Alameen Towers	Egypt	Ministries building	Egypt
Al Kayan District cooling project	Egypt	Miracle Factory	Egypt
Al Mansoura 2, 4 & 5	Egypt	Misr Makasa	Egypt
Alamein tower Orascom	Egypt	Mivida park	Egypt
Alexandria International Airport	Egypt	NCP Nile Corniche	Egypt
Algeria Club house	Egypt	New Al Almain Towers	Egypt
Almassa al alamien	Egypt	New Cairo Festival City	Egypt
Americana mall shiekh zaid	Egypt	New Cairo Mall	Egypt
Aphche Procurement Kattamya Airbase	Egypt	New Capital Gama	Egypt
Bernice civil airport	Egypt	New parliament building	Egypt
BNP Paribas Bank	Egypt	Nile Corniche St.Regis Cairo Project	Egypt
Cairo Airport APM	Egypt	opera 5000 New capital	Egypt
Cairo Airport T3	Egypt	Parliament building	Egypt
Cairo Festival City	Egypt	Polygon Project	Egypt
Camp Zafer herat	Egypt	Project Service Building in Administrative entity,	Egypt
CFC Oriana villa phase 3	Egypt	Qatameya Airport	Egypt
CFC Project	Egypt	Sea Shell project	Egypt
City star sharm el sheikh	Egypt	Secon Nile Towers Seimens Egypt Task	Egypt
Club One Wadi ElNakhil Project	Egypt	Service Buildding Project Haikstep	Egypt
Coca cola	Egypt	Service Smart Village Office Complex Phase I	Egypt
Dar EL Eshara	Egypt	Sharm el sheikh Hotel	Egypt
Dar El Fouad Hospital	Egypt	Smart Village Egyptian Financial	Egypt
Dar El Fouad Nasr City	Egypt	SOCIAL CLUB	Egypt
Dar New premises	Egypt	sodic (Strip II)	Egypt
East suburb mall	Egypt	Sodic 40 west	Egypt
Edita 6 Of October	Egypt	Targa Algeria Project	Egypt
El Azhra Mosque	Egypt	The Grand Egyptian Museum	Egypt
El Burullus Station	Egypt	The Nile Ritz	Egypt
El Gezeira Sporting Club	Egypt	Triumph Hotel	Egypt
El kayan 110 District Cooling,	Egypt	Uniliver Mashreq	Egypt
El Mansoura 2 zone (3, 4)	Egypt	UP Town mokkatam	Egypt
El Masa Hotel	Egypt	Uptown Cairo	Egypt
El rawan -Ozey	Egypt	Villa Yassin Mansour	Egypt
El Rehab Mall	Egypt	Wadi El Nakheil	Egypt
El Shabab Power Station	Egypt	West Damiata power Station	Egypt
El Tahrir Complex	Egypt	Zeweil City	Egypt
Engineering house warehouse	Egypt	Ethiopia Airport	Ethiopia
Entertainment City	Egypt	Al Basheer Hospital	Jordan
ERC Refinery project – Mostorod	Egypt	Dar Al Hikma HQ	Jordan
ERC Musturod	Egypt	SINOGULF ABDALI TOWER	Jordan
Four Seasons Hotel Building	Egypt	Ahlia KIPIC NRP AL ZOUR	KSA
Four seasons sharm elshiekh	Egypt	AJDAN RISE TOWER	KSA
Galala Resort Al Kayan Defense Force	Egypt	Al Shaya Riyadh Warehouse	KSA
Galeria 40	Egypt	ARAMCO DHADRAN Housing PKG 1,2,3&4	KSA
Ghabbour Service Center	Egypt	ARAMCO - Jubail project	KSA
Golden Dome	Egypt	C32 ROYAL Comm & SEPCO	KSA
Grand Museum	Egypt	CMC Hospital	KSA
H6 Marassi	Egypt	CRCC project	KSA
Horus Factory	Egypt	Diplomatic HQ	KSA
Hurghada International Airport	Egypt	Farabi Project	KSA

Project Reference List



KEY PROJECTS	COUNTRY	KEY PROJECTS	COUNTRY
Ghamata Mall	KSA	LOWER FARS HEAVY OIL DEVELOPMENT PROJECT	Kuwait
HHR Mekkah Bin Laden Makkah project	KSA	MINISTRY OF EDUCATION HEADQUARTERS	Kuwait
Jabal Omar Development Makkah	KSA	MULTIPURPOSE HALL BAYAN PALACE	Kuwait
JIZAN Hospital 500 Bed	KSA	National Housing H.Q.	Kuwait
Jumaiza Hotel	KSA	NBK NEW HEADQUARTERS	Kuwait
KAP King Abdul Aziz Project	KSA	South Abudlla Al Mubarak Booster Pump Station	Kuwait
KAP 1 project	KSA	TALA HOTEL	Kuwait
KAP 2 project	KSA	YAAL COMPLEX	Kuwait
KAP 5 project	KSA	Intercontinental Senegal	Lebanon
KAUST project	KSA	Al Fardan project	Oman
KFSH Part 1 Kabbani	KSA	Mall of Oman	Oman
Landmark Warehouse	KSA	mazone daiary	Oman
Metro "sharqawi"	KSA	Oman museum	Oman
MOD Kifah project	KSA	ROP academy and city center	Oman
Park Inn Riyadh	KSA	ROP central prison	Oman
Riyadh Metro project	KSA	salalah grand mall	Oman
ROYAL COMMISSION Jubail Alhoda	KSA	Sohar city center	Oman
Royal Commission	KSA	Bahria Tower Icon	Pakistan
SABIC Headquarter Project	KSA	Al Baker Towers	Qatar
Sail Tower "Jaffali"	KSA	Ashghal Static Lab	Qatar
SANG Hospital & Royal Commission	KSA	Const of Contarct Package ISF	Qatar
SEC HQ	KSA	ISF Camp Solar System	Qatar
Sharma Hotels Azmeel	KSA	JW Marriott Qatar	Qatar
SHARMA Bawani	KSA	Lusail Plaza	Qatar
SRCC Abha	KSA	Lusail Stadium	Qatar
Sulaiman Habib Hospital	KSA	Msheirb Down Town project	Qatar
Tadaul Tower & Metro project	KSA	Qatar Foundation Stadium	Qatar
Wadi Al Hada	KSA	Qatar Gas Development	Qatar
Academic Support Facilities	Kuwait	Refinery Admin. Bldgs At Mesaieed, Doha Qatar	Qatar
ADMINISTRATION BUILDING BAYAN PALACE	Kuwait	Takyeeff & CCC Qatar Jersey	Qatar
AL AMIRI HOSPITAL EXPANSION	Kuwait	Thumama stadium	Qatar
AL KOUT MALL FAHAHEEL	Kuwait	(G+2+R)LABOR ACCOMMODATION	UAE
ASSIMA TOWER & HOTEL	Kuwait	(G+S+R) RESIDENTIAL BUILDINGS AT DIC, DUBAI	UAE
AVENUES PHASE 4	Kuwait	10 Vills At Jumeirah	UAE
C4I AHMEDI BUILDING	Kuwait	2 Vilas (G+1) For H.E. Khalifa Juma Al Naboodah	UAE
CENTRAL UTILITY PLANT 1 & 2 SABAH AL SALEM UNIVERSITY CITY	Kuwait	224 VILLAS AT AKOYA PARK BY DAMAC	UAE
COLLEGE OF ARTS & EDUCATION SABAH AL SALEM UNIVERSITY CITY	Kuwait	2B+G+11 Furnished Apartment P320 rafia.	UAE
COLLEGE OF BUSINESS & WOMEN	Kuwait	2B+G+23 Res/Comm. Bldg. Al Majaz, Shj. For Mr. Munir Kaloti.	UAE
College of Sharia	Kuwait	2B+G+29 & 2B+G+6 Tower Bldgs. On Pl# 392 447& 392 8 At Marsa Dubai For Mr.	UAE
DECKED PARKING, SHELTER AND ANCILLARY BUILDINGS BID PACK 6A&B	Kuwait	2B+G+3 For Kazim Al Khafaji	UAE
DESIGN, DEVELOPMENT, CONSTRUCTION AND MAINTENANCE OF AL SHAHEED PARK FOR AMIRI DIWAN	Kuwait	2B+G+4 Bldg. At Al Garhood, Dubai For M/S. Real Estate Bank.	UAE
FARWANIYA COURT COMPLEX	Kuwait	2B+G+7 Bldg. For Jamal Al Ghurair.	UAE
FARWANIYA HOSPITAL	Kuwait	2B+G+7 Bldg. For Mr. Mohd.	UAE
HASSAWI MANSION	Kuwait	2B+G+M+1 Sun & Sand Sports Center On Pl# 332 901 And Nael Sulouh Mixed Use Devprnt	UAE
Hawally Court	Kuwait	3 RES BUILDINGS@ IMPZ	UAE
JABER AL AHMAD AL JABER AL SABAH HOSPITAL (Package 2)	Kuwait	3 VILLAS, SWIMMING POOL & GYM AT	UAE
KISR ADMINISTRATION BUILDING & MOSQUE PROJECT	Kuwait	3B+G+39 Fl. Comm/Res. Ui & U2 Jumeirah Lake Tower Dubai	UAE
KNPC CFP PROJECT: MAB2 PACKAGE	Kuwait	3B+G+6P+1 Storey Comm/Off Bldg On Pl# Ph1, C.019, Business Bay, Dubai	UAE
KNPC Al Zour Refinery	Kuwait	3B+G+7 Bldg. For Mr. Ahmed Al Attar	UAE
KOC CONSTRUCTION OF OIL & GAS EXHIBITION CENTER	Kuwait	3STAR HOTEL UAE	UAE
Kuwait Airport New Passengers Terminal	Kuwait	43 Storey Hotel Bldg Dubai Mall Hotel	UAE
KUWAIT CANCER CENTER	Kuwait	48 Villas At Al Garhoud	UAE
Kuwait Finance House	Kuwait	90 TYPICAL VILLAS FOR JUMEIRAH VILLAGE L.L.C	UAE
Kuwait International Airport	Kuwait	Abu Dhabi Co Operative Society.	UAE
KUWAIT INVESTMENT AUTHORITY HEADQUARTERS	Kuwait	ABU DHABI ISLAMIC BANK HQ	UAE
KUWAIT NATIONAL MUSEUM	Kuwait	Ac/2B+G+M+7Storey Bldg. Dubai	UAE
KUWAIT NEW REFINERY	Kuwait	Adnoc Business Center UAE EI	UAE
Kuwait University Administrative Facilities	Kuwait	Ahmed Al Owais Building Dubai.	UAE
LEVEL TOWER SALMIYA	Kuwait	Al Roumi Building Dubai.	UAE

Project Reference List



KEY PROJECTS	COUNTRY	KEY PROJECTS	COUNTRY
AL OW AIS TOW ER	UAE	CENTRAL PARK CP08	UAE
Al Abbasi Tower Building Dubai.	UAE	Cinema Complex In Jabel Ali Free Zone.	UAE
AL BADAIA RESIDENTIAL BUILDING AL SATWA	UAE	CITY WALK - PLOT 1,5,6 & 8	UAE
AL BADRAH WATER FRONT, JABEL ALI	UAE	City Walk Residences	UAE
Al bonian Dubai	UAE	Comm/Res. Bldg On Pl# 373 1352, Al Barsha First	UAE
Al Durra Center – Sharjah	UAE	COMMERCIAL BLG FOR H.E HAMAD MOHAMMED AL SUWAIDI	UAE
Al Fardan Twin Tower At West Bay Doha	UAE	COMMERCIAL BUILDING FOR MR. THANI OBAID KHALIFA AL MUHAIRI	UAE
AL FATTAN CRYSTAL TOWERS, DUBAI	UAE	Commercial/Res For Mr. Khalid Al Ghurair	UAE
al garhood mixed complex. Dubai hydo point	UAE	CONSTRUCTION OF 10 RESIDENTIAL BUILDING MEYDAN 1 AZIZI	UAE
Al Habtoor City Project	UAE	Creek Horizon	UAE
AL MAKTOUM HOSPITAL SITE REDEVELOPMENT PHASE II.	UAE	DALMA TOWER, DUBAI	UAE
Al Marfa Hospital At Abu Dhabi.	UAE	DAMAC GOLF GLUB	UAE
Al Nakheel Village Abudhabi	UAE	Damac Part Tower	UAE
Al Phamed New Extension Dubai	UAE	DC DRY PORT UP GRADATION FOR DUBAI CUSTOM AT AL AWEER, DUBAI	UAE
AL RAHA BEACH DEVELOPMENT	UAE	Deena Island.	UAE
AL REEM ISLAND AREA 1 ZONED	UAE	Defense Job Job No. T 357.	UAE
Al Ruwais Refinery.	UAE	Deira Water Front	UAE
Al Sayer Building.	UAE	DFC SALSA MALL EXTENSION	UAE
al shahama 250 villa Dubai point	UAE	DIFC LIBERTY HOUSE	UAE
Al Warqa 544 Key Villas	UAE	DISCOVERY GARDENS	UAE
Al Wasl RAK UAE Val HP	UAE	Dubai Silicon Oasis	UAE
Ali Bajjash	UAE	DUBAI AIRPORT EXPANSION	UAE
ALMAS TOWER, JLT, DUBAI	UAE	Dubai Airport Freezone	UAE
AMMROC, ALAIN	UAE	DUBAI CREEK HARBOUR DEVELOPMENT	UAE
Andaz Hotel UAE VAL CHW HP	UAE	Dubai Creek Tower	UAE
Appartment Retail Complex Hamriya.	UAE	Dubai For Mr. Sameer Mohammed Gargash	UAE
Arabian Ranches 158 Villas	UAE	DUBAI HILL ESTATE	UAE
Arabian Ranches 594 & 88 Villas, Dubai	UAE	Dubai Investment park	UAE
ARCADIA ACADEMY SECONDARY SCHOOL	UAE	DUBAI MARINA MALL	UAE
ATLANTIS, PALM ISLAND, DUBAI	UAE	DUBAI METRO DEPOTS, JABEL ALI & QUASIS	UAE
Automobile Showroom For Mr. Khalid Juma Al Majid At Al Khabeesi.	UAE	DUBAI METRO STATIONS	UAE
B+G+? Res. Bldg. At Zareebab Doi.	UAE	DUBAI SUSTAINABLE CITY	UAE
B+G+1 Villa At Emirates Hills For Mr. Zafer Iqbal	UAE	DUBAI TRADE CENTRE DISTRICT PHASE 1A6	UAE
B+G+14 Mr. Razouk Bldg. Sharjah.	UAE	DUBAI WHARF AT CULTURE VILLAGE DUBAI	UAE
B+G+20 Beach Resort P No: 5	UAE	DUBAI WORLD CENTRAL PHASE I	UAE
B+G+21 Ghurair Al Qubaisi	UAE	Duniya Tower UAE HP	UAE
B+G+3 Bldg. For H. H. M. Al Nhyan.	UAE	Duo425, Ekfc New Laundry Plot# 598 896 At Dubai Investment Park	UAE
B+G+3 Story Comm. & Res. Complex.	UAE	EMERALD PALACE, PALM ISLAND	UAE
B+G+36 Res. Bldg For Mr. Mohd Khalfan Kharbash Abdulla , Dubai	UAE	EMIR ATI HOUSING DEVEL OPMENT, AL AIN	UAE
B+G+4+R RESIDENTIAL BLDG@ JUMEIRAH VILLAGE TRIANGLE	UAE	EMIRATES FLIGHT CATERING	UAE
B+G+II+R RESIDENTIAL BUILDING	UAE	Emirates Flight Catering Facility & Emirates Crew Training College	UAE
BAY SQUARE BUSINES BAY	UAE	Emirates Hill Majlis Res. Complex Pa 10 T1, Apartment Bldgs.	UAE
Beach Vista	UAE	Emirates Lakes Hattan Luxury & Executive Villas	UAE
Bin Mujrein Building	UAE	EMIRATES PARK TOW ER HOTEL	UAE
Bldg For Mr. Mohammed Ahmad Al Humeiri Pl# C 14, Zone	UAE	Emirates Warehouse Dxb Airport Free Zone	UAE
BRIGHT STAR HOT	UAE	Emrill Maintenance	UAE
BRIGHT START BEACH RESORT	UAE	Energy SO2	UAE
BURJ AL SALAM, TRADE CENTRE	UAE	ETISALAT Building	UAE
BURJ DUBAI, PLOT 29 & 30	UAE	EXPO2020	UAE
BURJ VIEWS	UAE	FAIRMONT HOTEL & SERVICED APARTMENTS	UAE
BUSINESS BAY ROADS & INFRASTRUCTURE	UAE	FAIRWAY VISTAS, EMAAR 65 VILLAS, DUBAI HILL ESTATE	UAE
Business Park Phase 1 & 2	UAE	Fardan Bin Ali Fardan Al Fardan.	UAE
BVLGARI HOTEL RESIDENCE PROJECT	UAE	Fujairah Airport	UAE
C2504 Schlumberger Mic Mea Learning Center	UAE	G+13 Building Gulf Insurance.	UAE
CANAL POINT HOSPITAL	UAE	G+2 PRIMARY & NURSERY SCHOOL	UAE
CAR PARKING AT E 11 IN ABUDHABI, DEPARTMENT OF TRANSPORT	UAE	G+3 Res & commercial Bldg. At AL Karama	UAE
Car Showroom, Spareparts Center & Work shop O Plot No 368 397 Al Goze Ind Area 3Rd	UAE	G+4 Bldg On Pl#319 040 Oud Metha For MIS. Al Naser Sports Club	UAE
CAYAN CANTARA RESIDENTAL & SERVICED APARTMENT TOWERS	UAE	G+4 Bldg. For Juma Al Majid	UAE
Centara Hotel UAE	UAE	G+6 Al Wasl Al Shirawi	UAE

Project Reference List



KEY PROJECTS	COUNTRY	KEY PROJECTS	COUNTRY
G+I CLUB VISTA & MARE AT PALM JUMEIRAH	UAE	NEW YORK UNIVERSITY, ABU DHABI	UAE
G+M+18 Floors Building.	UAE	NIKKI BEACH RESORT DEVELOPMENT	UAE
G+M+3P+40 Res. Towr At Al Majaz Sharjah. (Danat Al Buhairah).	UAE	Obaid Bel Rashid Bldg.	UAE
G+M+9 Floor Bldg. For Mr. Ghurair Mohd Al Ojan Qubaisi On P#E 16102, Adh	UAE	Obstetrics & Gynecology Dept Mr#D 5782, Job# 5022300 Fujairah Hospital	UAE
Ghadeer villas	UAE	Opera Tower UAE	UAE
GROSSVENOR BUILDING	UAE	PN1303 DICEC NEW HALLS EXPANSION	UAE
HABIB BANK AG ZURICH HQ, DUBAI	UAE	Porsche Car Workshop	UAE
Hampton Hotel Al Barsha	UAE	PORSHE SHOWROOM	UAE
HARBOUR VIEWS	UAE	PORT VIEW RESIDENTIAL BUILDING MADINAT DUBAI AL MELAHEYAH	UAE
Health Care Center At Khalifa «A» City And Health Care Center At Baniyas, Abu Dhabi	UAE	Rashid Hospital Accident & Emergency / Trauma Centre	UAE
Holiday Inn Hotel Dubai.	UAE	REEF TOWER, JLT, DUBAI	UAE
Hs 103 Jbr Hotel H04 Tower (C07)	UAE	Reem mall/Military camp Abu Dahbi	UAE
IBN BATTUTA MALL EXPA NSION N CONSTRUCTION OF HOTEL	UAE	RENAISSANCE HOTEL	UAE
IKEA, DOHA QATAR	UAE	Res. Building For Mr. Abul Haj.	UAE
IMPZ ROADS & INFRASTRUCTURE	UAE	RESIDENTIAL BUILDING FOR REGAL PROPERTY INVESTMENT	UAE
INDIGO TOWER JLT	UAE	RESIDENTIAL PLOTS AT AL QUOZ, 9 TOWERS	UAE
JBR 01 HOTEL	UAE	ROSE WOOD HOTEL, ABU DHABI	UAE
JBR 02 HOTEL	UAE	Royal Atlantis UAE	UAE
JEWEL OF CREEK DEVELOPMENT	UAE	Sahara Shopping Center Sharjah	UAE
Jumeira Beach Complex	UAE	SARAYA AQOBA JORDAN	UAE
Jumeirah Gate Project	UAE	SERENIA RESIDENCE	UAE
JUMEIRAH OPEN BEACH - LA MER	UAE	Sharjah Court Complex	UAE
JVC District Cooling	UAE	Sharjah Twin Tower.	UAE
KENT COLLEGE AT DUBAI	UAE	SHEIKH KHALIFA CENTRAL HOSPITAL FUJAIRAH	UAE
KHALIDIYA PLAZA VIEW	UAE	Sheraton Creek Hotelrenovation	UAE
Khalidiya Tower	UAE	SHERATON CREEK HOTELREVNATION	UAE
khalidya Tower	UAE	SRS School	UAE
Korfakkan Police Station	UAE	Tabreed District Cooling - Zayed Military City	UAE
LABOUR CAMP @ AL TTAY	UAE	TAJ RESIDENSES, PALM JUMEIRAH	UAE
LADYBIRD EARLY LEARNING CENTER	UAE	Tariq Al Masood Villa Project	UAE
Landmark Headquarter Building	UAE	Tech Tower UAE	UAE
Icu, Smu & New Kitchen Facilities At Al Tawam Hospital & Al Marfa AUAE	UAE	THE ADDRESS RESIDENCE	UAE
LOGISTIC FACILITY FOR REAL FZE	UAE	THE ARCADIA PRIMARY SCHOOL	UAE
LOGO ISLAND	UAE	THE AVENUE RETAIL DEVELOPMENT	UAE
Lulu Mall	UAE	The Onyx Complex	UAE
MADINA HOTEL	UAE	THE PAD TOWER, BUSINESS BAY	UAE
MAMSHA AL SAADIYAT ISLAND ABU DHABI	UAE	THE POINTE AT PALM JUMEIRAH	UAE
MARINA MALL OFFICE TOW ER	UAE	THE ROYAL ATLANTIS RESORT AND RESIDENCES	UAE
marsa al seef dubai hpoint	UAE	The Waves Residential Tower On Plot 4A At Dubai Marina	UAE
MARYAH PLAZA PHASE 1@ MARYAH ISLAND	UAE	TIARA HOTEL@ PALM JUMERIAH	UAE
MASHREQ BANK HQ TOWER	UAE	TIFFANI TOWERS JLT	UAE
Mayan Development UAE	UAE	TILAL AL GHAF SHOW VILLAS & SALES PAVILION	UAE
maydan beach hotel dubai	UAE	TOWN SQUARE DEVELOPMENT RAWDA APARTEMENT DUBAI	UAE
MBR CITY DISTRICT 1 PHASE 1	UAE	TRADITIONAL SOUQ	UAE
MEDICLINIC HOSPITAL EXPA NSION , AIRPORT ROAD ABU DHABI	UAE	Twin Commercial Bldgs On Plot #C65&C65 Sector E 25, Abu Dhabi	UAE
Mercato Mall – Jumeirah	UAE	Umm UI Quain Court Complex	UAE
MEYDAN HEIGHTS PHASE B, DUBAI	UAE	Union Co Operative Society Bldg.	UAE
MEYDAN HEIGHTS, DUBAI	UAE	Uraqi Al Theray Military Camp Mw/2118,Dubai.	UAE
MILITARY HOSPITAL@ MALIHA	UAE	Villa & Majlis Bl. For Mr. Jamal Al Ghurair.	UAE
Military Survey Dept	UAE	Villa Nova Trinity UAE	UAE
MIRFA IWPP	UAE	W HOTEL & RESIDENCE	UAE
MOVENPICK HOTEL, PALM JUMEIRAH	UAE	WAFI CITY MAL EXTENSION	UAE
NASARENA	UAE	WAFI HOTEL COMPLE X & MALL EXPA NSION PHASE 8	UAE
Nasser Lootha Building.	UAE	WARNER BROS. THEME PARK AT ABU DHABI	UAE
NATIONAL REHABILITATION CENTRE, ABU DHABI	UAE	Water Desalination Plant .	UAE
Naturalisation & Res. Bldg At Ajman	UAE	Water Front Tower, Dubai. (Proposed Bldg. B3+Gr+1St+18 Flo+Roof. At Marsa Dubai	UAE
New Factory For Gulf Craft At Umm Al Quwain	UAE	WOW Hotel	UAE
New Lab Sharjah University	UAE	Uganda airport new terminal	Uganda
NEW VISITOR CENTRE AT SHK. ZAYED MOSQUE	UAE	UNION PLACE APARTMENTS	UAE

Contents

General Valves

GATE VALVE

B3001/B3001N	1
W-WB131	2
W-WB132	3
W-WZ15W-25T	4
R3001/R3001N	5
E3243	6
405-NRS	7
W-Z45H-16Q	8
W-Z45H-25Q	9
W-Z45H-125Q	10
W-Z41H-16Q	11
W-Z41H-25Q	12
W-Z41H-125Q	13

BALL VALVE

FBV-25/FBV-25N	14
LF-FBV	15
W-L-FBV-BSPT	16
LFFBV-3C-M1	17
FBV-3C	18
R6001	19
286W/287W	20
290	22

BUTTERFLY VALVES

W-W1911-L/G	23
W-W1924-L/G	25
BF-03	26
W-W1111-L/G	28
W-W1124-L/G	30
BF-04	32

STRAINERS

YG11-20/YG11-20N	34
LF777S	35
R2001/R2001N	36
W-W4112	37
W-YG41-25C	39
77F-DI-125/77F-FDA-DI-125	40
97FB-CI	41

AIR VENT

FV-4M1	42
MVD	44
MV	45
2161C	46
MXV	47

CHECK VALVE

B5002/B5002N	48
R5001/R5001N	49
R5002/R5002N	50
W-H77X-16Q	51
815	52
402	53
W-H44T-16Q	54
W-H44T-125Q	55
R5003	56
60S	57
302	58

302P	59
302Z	60

GLOBE VALVE

W-WB251-25T	61
W-J41T-16Z	62

HOSE BIB

LFSC	63
LFSC8	64

Protection Valves

Pressure Regulators

LFN45B	65
LF25AUB-Z3	67
LFN223	69
DRV	70
DRVN	71
DRVM	72
DRVMN	73
DRVD	74
7BIS	76
10BIS	77
11BIS	78

Automatic Control Valves

W-M115	79
W-M115-74	81
PR500	83
W-200X-25C	85
W-M110-10	86
W-M110-14	88
W-M116	90
W-500X-25C	92
W-M113-12/6	93

Backflow Preventor

LF007	95
LF709	97
774	99
LF009	101
LF909-FS-small	105
LF909-FS	108
757	111
BA-BM	114
BA4760	116
LF7R	118
LF8/LF8B	119

Mixing Valves

LFMMV	120
LFN170/LFN170 CSUT	121
LF1170	122
61C/62C/63C	123
T70	125
INTELLISTATION JR.	126
INTELLISTATION	127



Contents

Relief Valves

LF174A	130
LF530C	131
LFN36	132
"Series 1L, 1XL, 10L and 100XL"	133
FP53L	134

Float Valves

R1001	135
-------	-----

Expansion Tanks

DET-A	136
PLT	137
ETX	138

Balancing Valves

Motorized Valves

W-W1111-EK/ET	139
W-W1911-EK/ET	141
W-W1924-EK/ET	143
W-W1124-EK/ET	145
W-ECBV-20T	147
W-ECBV-16Q	149
W-942-16/25Q	151
W-943-16/25Q	153
2131	155
3131	157
4131	159
EMUJC-010 24V	161
22CX	166

Static Balancing Valve

STBV-25/STBV-25N	169
W-STBV-16Q	171
W-STBV-25Q	176
SERIES CF	181
CSM-61-T	182
CSM-91	183

Differential Pressure Control Valve

W-DPBV-20T	184
W-DPBV-16Q/25Q (DN65-DN150)	186
W-DPBV-16Q/25Q (DN200-DN250)	188

Pressure Independent Control Valve

W-PICVXXX-25T/25Q	190
W-AR	193
W-PICVXXX-16Q/25Q (DN65-DN150)	195
W-PICVXXX-16Q/25Q (DN200-DN250)	196
W-AR12	197
W-A11	199
WATTS VAL-KIT	202

Intelligent Control Valve

W-SCBV-20T/16Q	204
----------------	-----



Metering Station

W-WMS-16P/25P	206
---------------	-----

Flow Switch

FLU 25PL	207
FS-200-W/FS-204-W	208

Triple Duty Valve

W-TDV-16Q/25Q	209
721/722	211
TDV	213

Suction Diffuser

W-JZG44-16Q	215
1011, 1012	216

Test Points

W-STBV-TP	217
LFTP	218

Fittings

Expansion Joints

W-ZKB	219
W-ZKT	220

Dielectric Unions

LF4001E	221
LF3003	222
LF3001A	223
LF3100	224

Gauges

Expansion Joints

LFDPG-1	225
LFDPG-5	226
M1-ABS	227
MG1-INOX 63-100	231

Temperature Gauge

LFTBR	234
LFTL	235
LFTA	236
TBR-VE	237

General Valves

- Gate Valve
- Ball Valve
- Butterfly Valves
- Strainers
- Air Vent
- Check Valve
- Globe Valve
- Hose Bib



B3001/ B3001N-EN-201909

Series B3001/ B3001N

Bronze Non-Rising Gate Valve

Size: DN15-DN50

The Watts B3001 Bronze Gate Valve is designed for the isolation of clean water and other non-corrosive fluids that are compatible with the material of construction. It's generally used in building services, water treatment etc.

Features

- Compact structure, reliable sealing
- Threaded bonnet
- Non-rising stem to minimize installation height
- Low pressure drop

Pressure-Temperature

- Nominal Pressure: PN20
- Temperature Range: 0 °C ~170 °C

Test Pressures

Pneumatic	Hydraulic
Shell: 6 bar	Shell: 30 bar
Seat: 6 bar	Seat: 22 bar

Material

NO.	Component	Material
1	Nut	Brass
2	I.D Plate	Aluminium
3	HandWheel	Aluminium
4	Stem	DZR Brass
5	Packing Nut	Brass
6	Ring	Brass
7	Packing	PTFE
8	Stem Bush	DZR Brass
9	Bonnet	Bronze
10	Body	Bronze
11	Disc	Bronze

Installation Dimensions

DN	d	L	H	D	A	Weight(kg)
15	12.7	49.5	74	56.5	15	0.26
20	19.1	53.5	85	69	16.3	0.37
25	25.4	62	106	75.5	19.1	0.55
32	31.8	70	113	81	21.4	0.83
40	38.2	77	132	94	21.4	1.23
50	50.9	87	155	100	25.7	1.84

*Available in both connection standard BSPT & NPT



Specification

- Design standard: BSEN 12288/ MSS SP-80
- Connection Standard: Threaded to ISO 7-1 BSPT. Available with NPT threading Model B3001N
- Test Standard: BS6755
- Medium: water

Approval

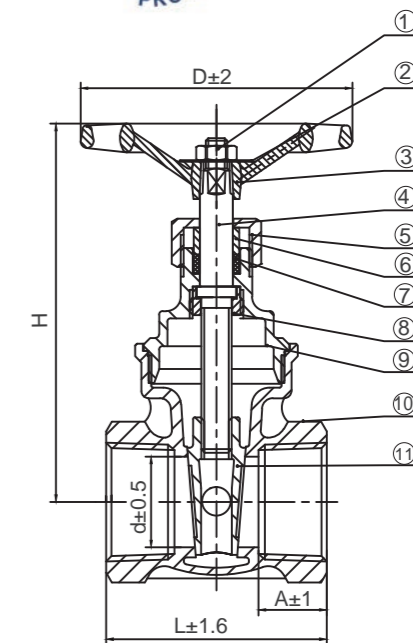



W-WB131-EN-202209

Series W-WB131

Bronze Non-Rising Gate Valve

Size: DN15-DN50

The Watts W-WB131 Bronze Gate Valve is designed for the isolation of clean water and other non-corrosive fluids that are compatible with the material of construction. It's generally used in building services, residential, etc.,

Features

- Compact structure, reliable sealing
- Threaded bonnet
- Solid wedge disc
- Unrestricted flow direction
- Low pressure drop

Pressure - Temperature

- Nominal Pressure: PN25
- Temperature Range: -20°C~120°C

Test Pressures

Pneumatic	Hydraulic
Shell: 6 bar	Shell: 37.5bar
Seat: 6 bar	Seat: 27.5 bar

Material

NO.	Component	Material
1	Body	Bronze
2	Bonnet	Bronze
3	Stem	DZR Brass
4	Disc	Bronze
5	Stuffing box	DZR Brass
6	Packing ring	PTFE
7	Gland	Brass
8	Packing nut	Brass
9	Handwheel	Aluminium
10	Name plate	Aluminium
11	Handwheel nut	Brass

Installation Dimensions

Connection Dimensions: ASME B1.20.1

DN	L*	H*	D*	Wt.(kg)
15	51	82	52	0.341
20	55	95	65	0.582
25	63	118	70	0.878
32	71	144	79	1.360
40	73	166	92	1.750
50	83	190	103	2.810

*All dimensions are in mm



Specification

- Connection Standard: BSPT to ISO 7-1, NPT to ASME 1.20.1
- Design Standard: BS5154/MSS SP-80
- Medium: water

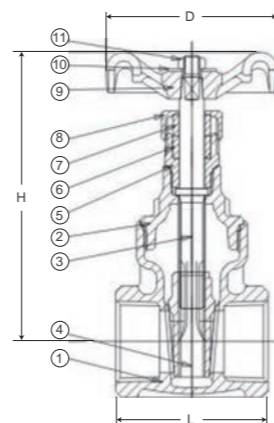

W-WB132-EN-202209

Series W-WB132

Bronze Rising Stem Gate Valve

Size: DN15-DN50

The Watts W-WB132 Bronze Rising Stem Gate Valve is designed for the isolation of clean water and other non-corrosive fluids that are compatible with the material of construction. It's generally used in building services, residential, etc.,

Features

- Compact structure, reliable sealing
- Threaded bonnet
- Solid wedge disc
- Unrestricted flow direction
- Low pressure drop
- Ease maintenance

Pressure - Temperature

- Nominal Pressure: PN32
- Temperature Range: -20°C~120°C

Test Pressures

Pneumatic	Hydraulic
Shell: 6 bar	Shell: 48 bar
Seat: 6 bar	Seat: 35.2 bar

Material

NO.	Component	Material
1	Body	Bronze
2	Bonnet	Bronze
3	Stem	Bronze
4	Disc	Bronze
5	Packing	PTFE
6	Clamping ring	Brass
7	Packing nut	Brass
8	Handwheel	Aluminium
9	Name plate	Aluminium
10	Handwheel nut	Brass

Installation Dimensions

DN	A*	B*	C*	Wt.(kg)
15	51	129	52	0.400
20	55	159	65	0.643
25	63	189	70	0.998
32	72.5	219	78	1.519
40	73	246	92	2.064
50	83	301	92	3.191

*All dimensions are in mm



Specification

- Connection Standard: BSPT to ISO 7-1, NPT to ASME 1.20.1
- Design Standard: BS5154/MSS SP-80
- Medium: water

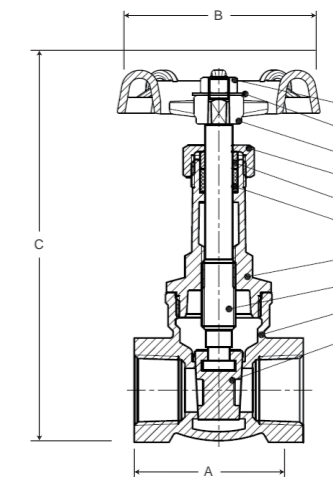



W-Z15W-25T-EN-202112

Series W-Z15W-25T

DZR Brass Gate Valve

Size: DN15-DN50

The Watts W-Z15W-25T Full-flow DZR Brass Gate Valve is designed to cut off or connect water, noncorrosive liquid in the pipeline. It's generally used in building services, water treatment, etc.

Features

- Compact structure, reliable sealing
- Simple structure, convenient maintenance
- In the closed state, the disc seal face and body seal face are not easily to erode by medium
- Convenient operation, short on-off time, easy to maintenance
- Unrestricted medium flow direction
- Small fluid resistance

Pressure - Temperature

- Nominal Pressure: PN25
- Working Temperature: 0°C~95°C

Working Principles

The stem nut installed on the gate drives the gate to rise and fall by stem rotation while the stem itself does not rise or fall.

Material

No.	Component	Material
1	Body	DZR Brass
2	Bonnet	DZR Brass
3	Disc	DZR Brass
4	Stem	DZR Brass
5	Handwheel	Cast Iron

Installation Dimensions

Size DN(mm)	Dimensions(mm)				
	L	H	A	B	G*
15	41	76	Ø13.5	Ø52	1/2"
20	46	84	Ø19	Ø58	3/4"
25	51	92	Ø25	Ø58	1"
32	58	110	Ø30	Ø78	1 1/4"
40	58	116	Ø35	Ø78	1 1/2"
50	70	145	Ø45	Ø100	2"

*Available in both connections standard BSPT & NPT

Installation Instructions

- The valve's rated parameters should match the equipment's. Make sure that the valve's rated flow satisfies the actual demand;
- The installer must be trained or experienced so as to operate the installation correctly;
- When installing the valve, valve should be fully closed ;
- A thorough check after installation is needed to ensure no errors;
- A thorough cleaning before installation is needed (chemical reagent can be applied if it is necessary) to ensure that there is not any rusting or dirt in the pipe. All the filters must be removed before washing to keep the pipe smoothly open;
- When beginning to wash the system, it is suggested to install the valve on a temporary pipe. After finishing system cleaning, move the valve back and install it on the system's pipe;
- This product should not be used when the fluid medium has high viscosity (contains much grease or mineral oil), or under corrosive circumstances;
- Valves are not allowed to be installed at the end of the pipe;
- Use threaded connector that meets the standard to connect the valve.



Specification

- Connection Standard: BSPT to ISO 7-1, NPT to ASME 1.20.1
- Test Standard: BS EN 12266-1/ MSS SP-80
- Working Medium: Water, noncorrosive liquid

Typical Application

- Water plant and water source project
- Environmental protection
- Municipal facilities
- Electric power and utilities
- Construction industry

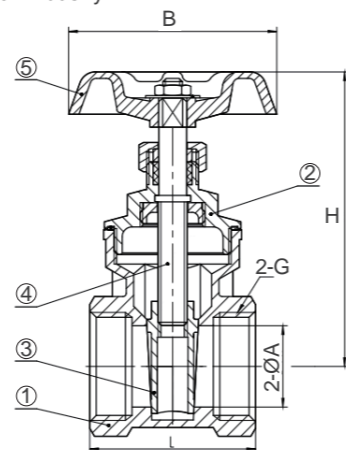

R3001/R3001N-EN-202105

Series R3001/R3001N

Brass Non-Rising Gate Valve

Size: DN15-DN50

The Watts R3001/R3001N Brass Gate Valve is designed for the isolation of clean water and other non-corrosive fluids that are compatible with the material of construction. It's generally used in building services, residential, etc.,

Features

- Compact structure, reliable sealing
- Threaded bonnet
- Non-rising stem to minimize installation height
- Low pressure drop

Pressure - Temperature

- Nominal Pressure: PN16
- Temperature Range: -20°C~110°C

Test Pressures

Pneumatic	Hydraulic
Shell: 6 bar	Shell: 24bar
Seat: 6 bar	Seat: 17.6 bar

Material

NO.	Component	Material
1	Body	Brass
2	Disc	Brass
3	Spindle	Brass
4	Bonnet	Brass
5	O-Ring	EPDM
6	Compression nut	Brass
7	Hand Wheel	Cast Iron
8	Nameplate	Aluminum
9	Nut	Steel

Installation Dimensions

Size DN(mm)	Dimensions(mm)						Wt.(kg)
	A	B	D	(H)	L	G*	
15	53	13	11	66	39	1/2"	0.21
20	53	15	11.5	68	44	3/4"	0.26
25	59	19.5	12	76	45.5	1"	0.35
32	72	26	13	90	49	1-1/4"	0.51
40	72	32	13.5	103.5	52.5	1-1/2"	0.64
50	78	38	16	115	58	2"	0.98

*Available in both connections standard BSPT & NPT



Specification

- Connection Standard: BSPT to ISO 7-1, NPT to ASME B1.20.1
- Medium: water
- Design Standard: BS EN 12288/ MSS SP-80

Approval

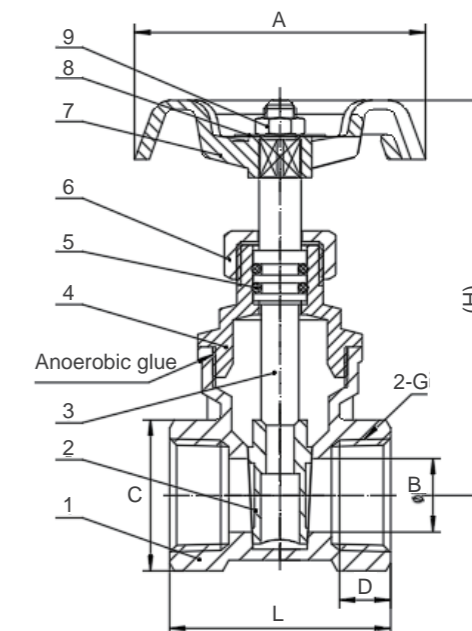



E3243-EN-202212

Series E3243

NRS Gate Valve, Resilient Seated

Size: DN50-DN600

The main function of Series E3243 is to realize the on-off function of pipeline system. It can be used in plumbing, HVAC, irrigation, commercial and industrial application.

Features

- Resilient seating
- Inside screw
- Superior stem packing with three O ring, one primary O ring seal and dust seal
- High strength thrust collar
- Epoxy Coating

Typical Application

- Water Works
- Environmental Protection
- Public Facilities
- Electricity and Utilities
- Building
- Paper industry

Material

NO.	Component	Material
1	Body	Ductile Iron GGG50
2	Disc	Ductile Iron + EPDM
3	Stem Nut	Brass Hpb59-1
4	Bonnet Gasket	EPDM
5	Stem	SS420
6	Bonnet	Ductile Iron GGG50
7	O ring	EPDM
8	Gland	Ductile Iron GGG50
9	Handwheel	Ductile Iron GGG50
10	Bolts	C45E/1045
11	Washers	C45E/1045
12	Dust Ring	EPDM
13	O Ring	EPDM
14	Axle Sleeve	Nylon 66
15	O Ring	EPDM
16	Screw	C45E/1045

Installation Dimensions

DN	L	H	D	K	n-Φd
50	178	270	165	125	4-Φ19
65	190	310	185	145	4-Φ19
80	203	325	200	160	8-Φ19
100	229	365	220	180	8-Φ19
125	254	400	250	210	8-Φ19
150	267	460	285	240	8-Φ23
200	292	560	340	295	12-Φ23
250	330	650	405	355	12-Φ28
300	356	740	460	410	12-Φ28
350	381	820	520	470	16-Φ28
400	406	900	580	525	16-Φ31
450	432	990	640	585	20-Φ31
500	457	1070	715	650	20-Φ34
600	508	1270	840	770	20-Φ37



Specifications

- Nominal Pressure: PN16
- Temperature Range: 0°C~80°C
- Design Standard: BS5163, EN1171, EN1074-2
- Connection Standard: EN1092-2
- Test Standard: EN12266-1
- Working Medium: Water

Test Pressure

Hydraulic
Shell: 24 bar
Seat: 17.6 bar

Approval

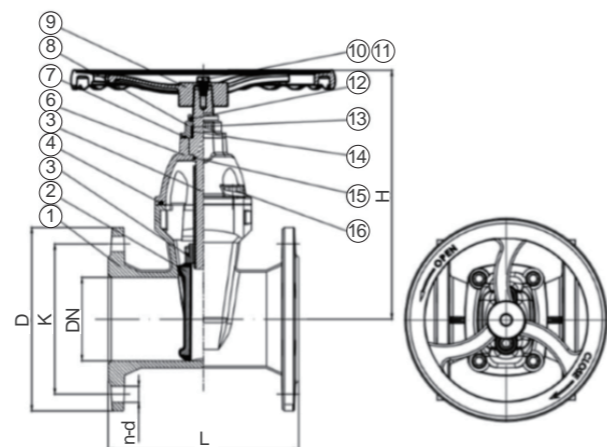

405-NRS-RW-EN-202003

Series 405-NRS-RW

Non-Rising Stem, Resilient Wedge, Flanged Gate Valves

Size: DN50-DN300

Series 405-NRS-RW Non-Rising Stem Resilient Wedge Gate Valves are available in sizes 2"-12" (50-300mm) flanged by flanged and 2½"-10" (65-250mm) flanged by grooved configurations. The valve body is epoxy coated internally and externally. The valve is operated by a Handwheel or an operating nut and valve key. The resilient wedge disc design offers both positive seating and resistance against high differential pressure. The Series 405-NRS-RW is best suited for service in either the fully open or closed position but is suitable for use as a throttling valve. This series is recommended for irrigation, potable water, water distribution service, feed lines and sewage disposal facilities.

Features

- Full port flow, low head loss
- Epoxy coated, internal and external
- Vulcanized encapsulated resilient wedge
- In-line serviceable
- Boss-tapped and plugged
- MSS-SP-70 conformance

Material

NO.	Component	Material
1	Body	Cast Iron
2	Bonnet	Cast Iron
3	Wedge	Cast Iron & Rubber (EDPM)
4	Hand Wheel	Cast Iron
5	Stem	Stainless Steel
6	Stuffing Bo	Cast Iron
7	O-ring A	Rubber
8	O-ring B	Rubber
9	Bonnet Gasket	Rubber
10	Stem Nut	Bronze
11	Wiper Ring	Rubber
12	Bonnet Bolt & Nut	Steel
13	Stud & Nut	Steel
14	Hand Wheel Washer	Steel
15	Top Nu	Steel
16	Operating Nut	Cast Iron
17	TAP Plug	Bronze

Installation Dimensions

Size (DN)	Flange Dimensions							405 (Fxf) Weight				
	L	D	C	h	n	T	W	H (NRS)	H1	S	lbs.	kgs.
2 50	7 178	6 152	4¼ 121	¾ 19	4	⅝ 16	7¼ 179	7¼ 179	3 76	⅝ 16	22	10
2½ 65	7½ 191	7 178	5½ 140	¾ 19	4	11/16 18	7¼ 179	9¼ 259	3½ 89	⅝ 16	29	13
3 80	8 200	7½ 191	6 152	¾ 19	4	¾ 19	7⅞ 200	10¼ 289	3¾ 95	11/16 18	40	18
4 100	9 229	9 229	7½ 191	¾ 19	8	15/16 24	8¼ 224	12½ 352	4½ 114	13/16 21	62	28
6 150	10½ 267	11 279	9½ 241	7/8 22	8	1 25	11 279	16¼ 470	5½ 140	15/16 24	111	50
8 200	11½ 292	13½ 343	11¼ 298	7/8 22	8	1½ 29	11 279	20⅞ 575	6¾ 171	1 25	194	88
10 250	13 330	16 406	14¼ 362	1 25	12	1¾ 30	12¾ 316	23⅞ 657	8 203	1¼ 32	272	123
12 300	14 356	19 483	17 432	1 25	12	1¾ 32	14 356	28¾ 773	9½ 241	1¼ 32	383	274



Specification

- Connection Standard: ASME B16.1 Class 125 & AWWA Class D - Flange end connection
AWWA C515 & C606 - Grooved end connection
- Flanged by flanged valve bodies shall comply with ASTM A126
- Flanged by grooved valve bodies shall comply with ASTM A536

Pressure - Temperature

- Nominal Pressure: 200psi (14 bar) CWP
- Maximum Temperature: 140°F (60°C)

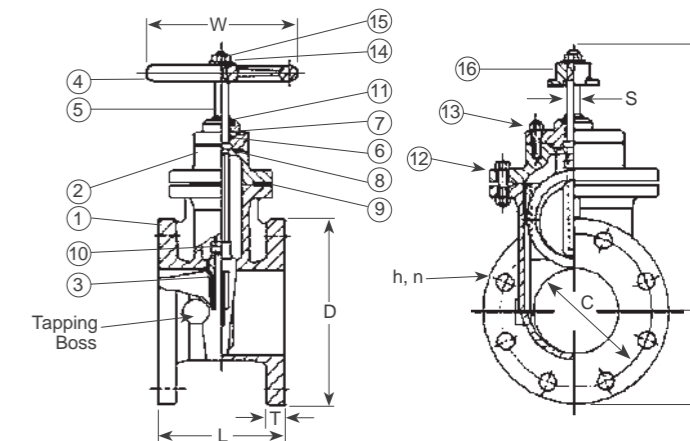



W-Z45H-16Q-EN-202206

Series W-Z45H-16Q

Gate Valve, NRS, Metal Seated

Size: DN50-DN400

Implementation of piping system on and off; Used in plumbing, HVAC, irrigation, commercial, and industrial application.

Features

- Low pressure drop
- Large temperature range
- Bidirectional flow
- Sealed performance
- Compact design
- High reliability and long durability

Pressure - Temperature

- Nominal Pressure: PN16
- Temperature Range: -10°C~ 120°C

Test Pressures

Hydraulic	
Shell:	24 bar
Seat:	17.6 bar

Material

Component	Material
Body	Ductile Iron
Bonnet	Ductile Iron
Seat	Bronze
Wedge	Ductile Iron
Wedge Trim	Bronze
Stem	Stainless Steel
Wedge Nut	Brass
Gasket	PTFE
Packing	EPDM
Packing Nut	Stainless Steel
Bonnet Bolts & Nuts	Stainless Steel
Hand Wheel	Ductile Iron

Installation Dimensions

Connection Dimension: PN16 to BS EN1092-2.

Size(mm)	50(mm)	65(mm)	80(mm)	100(mm)	125(mm)	150(mm)	200(mm)	250(mm)	300(mm)	350(mm)	400(mm)
L	178	190	203	229	254	267	292	330	356	381	406
H	214	223	262	323	380	438	518	615	705	790	855
D	180	200	200	220	254	280	315	405	405	558	558

Pressure-Temperature Chart

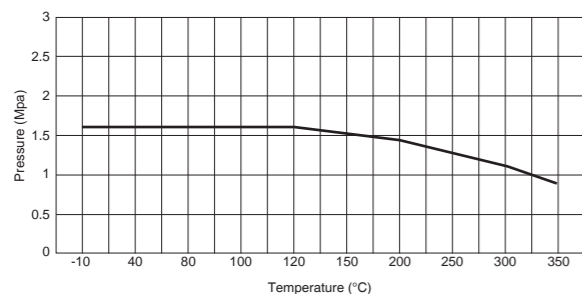

Specification

- Design Standard: EN 1171
- Connection Standard: PN16 to EN1092-2
- Corrosion Protection: internally and externally liquid epoxy painted

- Medium: water

Approval

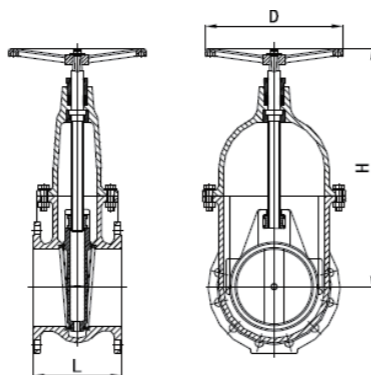

Characteristic Curve

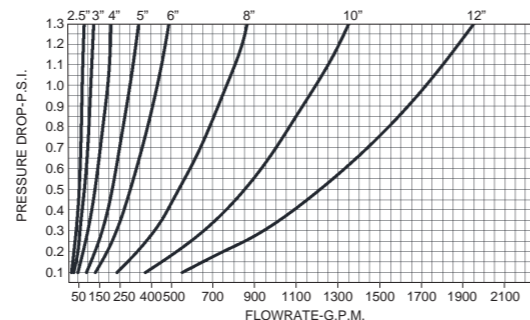

W-Z45H-25Q-EN-202206

Series W-Z45H-25Q

Gate Valve, NRS, Metal Seated

Size: DN50-DN300

Implementation of piping system on and off; Used in plumbing, HVAC, irrigation, commercial, and industrial application.

Features

- Low pressure drop
- Large temperature range
- Bidirectional flow
- Sealed performance
- Compact design
- High reliability and long durability

Pressure - Temperature

- Nominal Pressure: PN25
- Temperature Range: -10°C~ 120°C

Test Pressures

Hydraulic	
Shell:	37.5 bar
Seat:	27.5 bar

Material

Component	Material
Body	Ductile Iron
Bonnet	Ductile Iron
Seat	Bronze
Wedge	Ductile Iron
Wedge Trim	Bronze
Stem	Stainless Steel
Wedge Nut	Brass
Gasket	PTFE
Packing	EPDM
Packing Nut	Stainless Steel
Bonnet Bolts & Nuts	Stainless Steel
Hand Wheel	Ductile Iron

Installation Dimensions

Size(mm)	50(mm)	65(mm)	80(mm)	100(mm)	125(mm)	150(mm)	200(mm)	250(mm)	300(mm)
L	178	190	203	229	254	267	292	330	356
H	214	223	262	323	380	438	518	615	705
D	200	200	254	254	315	315	315	405	405

Pressure-Temperature Chart

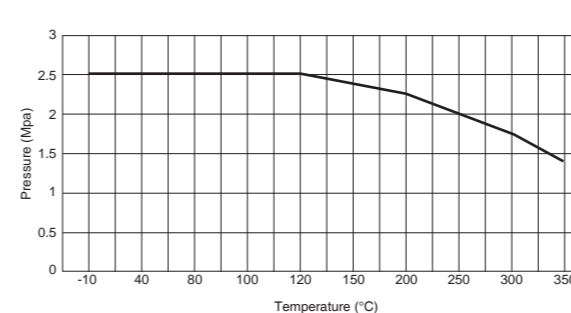

Specification

- Design Standard: EN 1171
- Connection Standard: PN25 to EN1092-2
- Corrosion Protection: internally and externally liquid epoxy painted

- Medium: water

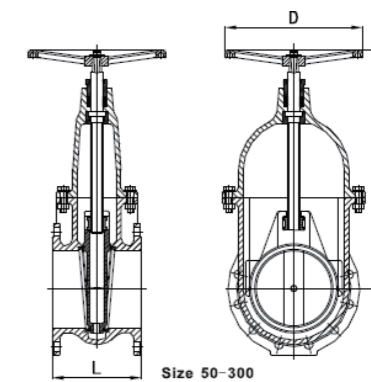

Characteristic Curve

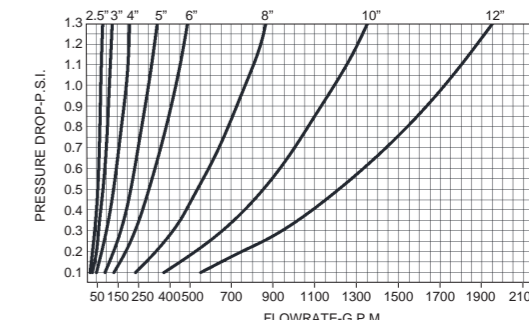



W-Z45H-125Q-EN-202206

Series W-Z45H-125Q

Gate Valve, NRS, Metal Seated

Size: DN50-DN400

Implementation of piping system on and off; Used in plumbing, HVAC, irrigation, commercial, and industrial application.

Features

- Low pressure drop
- Large temperature range
- Bidirectional flow
- Sealed performance
- Compact design
- High reliability and long durability

Pressure - Temperature

- Nominal Pressure: CL125
- Temperature Range: -10°C~ 120°C

Test Pressures

Hydraulic	
Shell:	24 bar
Seat:	17.6 bar

Material

Component	Material
Body	Ductile Iron
Bonnet	Ductile Iron
Seat	Bronze
Wedge	Ductile Iron
Wedge Trim	Bronze
Stem	Stainless Steel
Wedge Nut	Brass
Gasket	PTFE
Packing	EPDM
Packing Nut	Stainless Steel
Bonnet Bolts & Nuts	Stainless Steel
Hand Wheel	Ductile Iron

Installation Dimensions

Size(mm)	50(mm)	65(mm)	80(mm)	100(mm)	125(mm)	150(mm)	200(mm)	250(mm)	300(mm)	350(mm)	400(mm)
L	178	190	203	229	254	267	292	330	356	381	406
H	214	223	262	323	380	438	518	615	705	790	855
D	200	200	254	254	315	315	315	405	405	558	558

Pressure-Temperature Chart

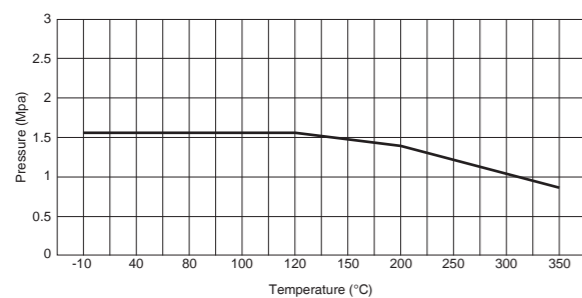

Specification

- Design Standard: EN 1171/MSS SP-70
- Connection Standard: CL125 to ANSI B16.1
- Corrosion Protection: internally and externally liquid epoxy painted
- Medium: water

Approval

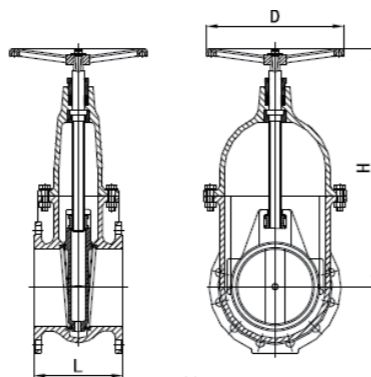

Characteristic Curve

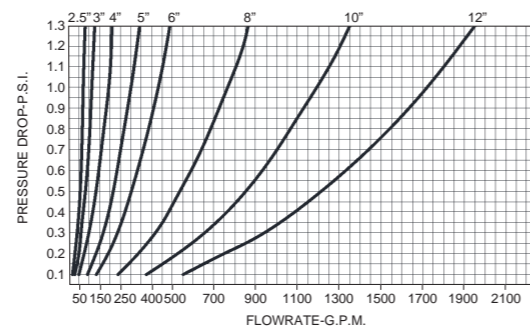

W-Z41H-16Q-EN-202206

Series W-Z41H-16Q

Gate Valve, OSY, Metal Seated

Size: DN50-DN400

Implementation of piping system on and off; Used in plumbing, HVAC, irrigation, commercial, and industrial application.

Features

- Low pressure drop
- Large temperature range
- Bidirectional flow
- Sealed performance
- Compact design
- High reliability and long durability

Pressure - Temperature

- Nominal Pressure: PN16
- Temperature Range: -10°C~ 120°C

Test Pressures

Hydraulic	
Shell:	24 bar
Seat:	17.6 bar

Material

Component	Material
Body	Ductile Iron
Bonnet	Ductile Iron
Seat	Bronze
Wedge	Ductile Iron
Wedge Trim	Bronze
Stem	Stainless Steel
Wedge Nut	Brass
Gasket	PTFE
Packing	EPDM
Packing Nut	Stainless Steel
Bonnet Bolts & Nuts	Stainless Steel
Hand Wheel	Ductile Iron

Installation Dimensions

Size(mm)	50(mm)	65(mm)	80(mm)	100(mm)	125(mm)	150(mm)	200(mm)	250(mm)	300(mm)	350(mm)	400(mm)
L	178	190	203	229	254	267	292	330	356	381	406
H	265	316	338	409	486	573	701	843	984	1990	2121
D	180	200	200	220	254	280	355	405	405	558	558

Pressure-Temperature Chart

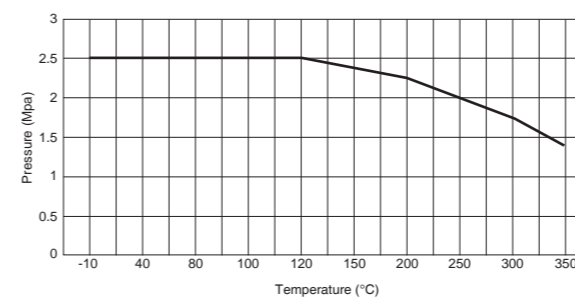

Specification

- Design Standard: EN 1171
- Connection Standard: PN16 to EN1092-2
- Corrosion Protection: internally and externally liquid epoxy painted
- Medium: water

Approval

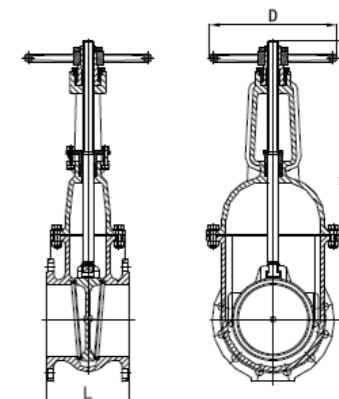

Characteristic Curve

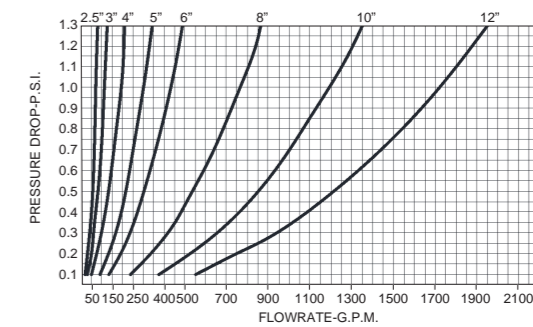



W-Z41H-25Q-EN-202206

Series W-Z41H-25Q

Gate Valve, OSY, Metal Seated

Size: DN50-DN300

Implementation of piping system on and off; Used in plumbing, HVAC, irrigation, commercial, and industrial application.

Features

- Low pressure drop
- Large temperature range
- Bidirectional flow
- Sealed performance
- Compact design
- High reliability and long durability

Pressure - Temperature

- Nominal Pressure: PN25
- Temperature Range: -10°C~ 120°C

Test Pressures

Hydraulic	
Shell:	37.5 bar
Seat:	27.5 bar

Material

Component	Material
Body	Ductile Iron
Bonnet	Ductile Iron
Seat	Bronze
Wedge	Ductile Iron
Wedge Trim	Bronze
Stem	Stainless Steel
Wedge Nut	Brass
Gasket	PTFE
Packing	EPDM
Packing Nut	Stainless Steel
Bonnet Bolts & Nuts	Stainless Steel
Hand Wheel	Ductile Iron

Installation Dimensions

Size(mm)	50(mm)	65(mm)	80(mm)	100(mm)	125(mm)	125(mm)	200(mm)	250(mm)	300(mm)
L	178	190	203	229	254	254	292	330	356
H	265	316	338	409	380	486	701	843	984
D	200	200	254	254	315	315	315	405	405

Pressure-Temperature Chart

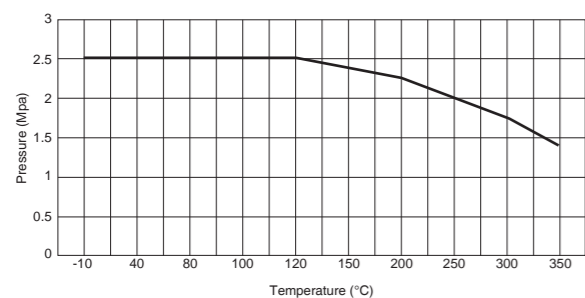

Specification

- Design Standard: EN 1171
- Connection Standard: PN25 to EN1092-2
- Corrosion Protection: internally and externally liquid epoxy painted
- Medium: water

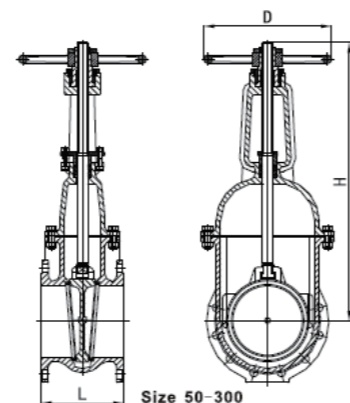

Characteristic Curve

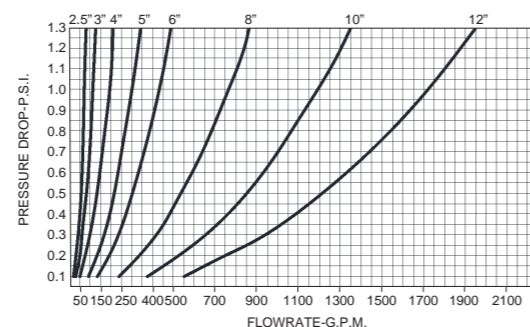

W-Z41H-125Q-EN-202206

Series W-Z41H-125Q

Gate Valve, OSY, Metal Seated

Size: DN50-DN400

Implementation of piping system on and off; Used in plumbing, HVAC, irrigation, commercial, and industrial application.

Features

- Low pressure drop
- Large temperature range
- Bidirectional flow
- Sealed performance
- Compact design
- High reliability and long durability

Pressure - Temperature

- Nominal Pressure: CL 125
- Temperature Range: -10°C~ 120°C

Test Pressures

Hydraulic	
Shell:	24 bar
Seat:	17.6 bar

Material

Component	Material
Body	Ductile Iron
Bonnet	Ductile Iron
Seat	Bronze
Wedge	Ductile Iron
Wedge Trim	Bronze
Stem	Stainless Steel
Wedge Nut	Brass
Gasket	PTFE
Packing	EPDM
Packing Nut	Stainless Steel
Bonnet Bolts & Nuts	Stainless Steel
Hand Wheel	Ductile Iron

Installation Dimensions

Size(mm)	50(mm)	65(mm)	80(mm)	100(mm)	125(mm)	150(mm)	200(mm)	250(mm)	300(mm)	350(mm)	400(mm)
L	178	190	203	229	254	267	292	330	356	381	406
H	267	316	338	409	486	573	701	843	984	1990	2121
D	200	200	254	254	315	315	315	405	405	558	558

Pressure-Temperature Chart

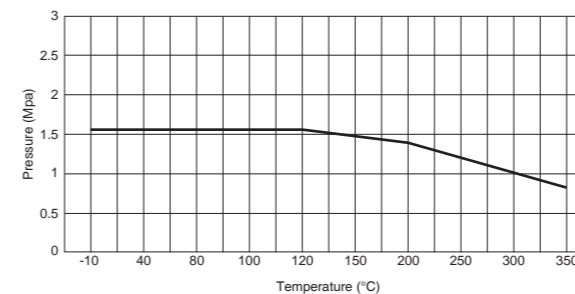

Specification

- Design Standard: EN 1171/ MSS SP-70
- Connection Standard: CL125 to ANSI B16.1
- Corrosion Protection: internally and externally liquid epoxy painted
- Working Medium: water

Approval

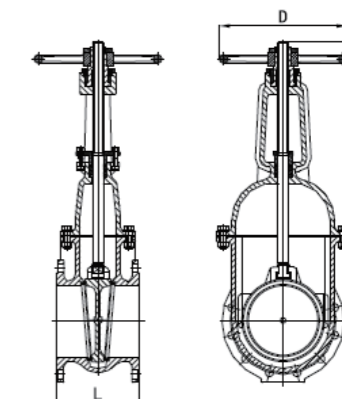

Characteristic Curve

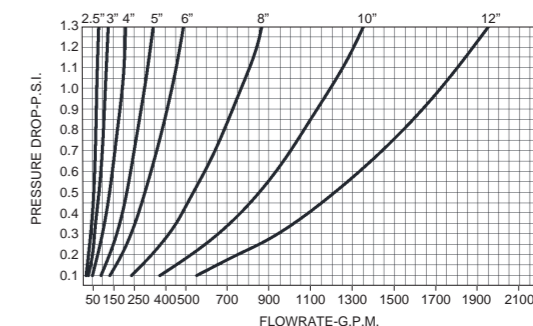



FBV-25/ 25N-EN-202203

Series FBV-25/FBV-25N

Bronze Ball Valve

Size: DN15-DN50

The Watts FBV-25 Bronze Ball Valve is light compact design, easy to install and operate. The series is designed to be used for water, oil and gas applications.

Features

- Light, compact, and easy to install and operate
- Minimal pressure drop due to full size ports
- Low operating torque

Pressure-Temperature

- Nominal Pressure: PN25
- Temperature Range: 0 °C ~170 °C

Test Pressures

Pneumatic	Hydraulic
Shell: 6 bar	Shell: 37.5 bar
Seat: 6 bar	Seat: 27.5 bar

Material

NO.	Component	Material
1	Seat Retainer	Bronze
2	Gasket	PTFE
3	Seat	PTFE
4	Ball	Brass
5	Body	Bronze
6	Stem	Brass
7	Stem Gasket	PTFE
8	Packing	PTFE
9	Gland Nut	Brass
10	Lever	Carbon Steel
11	Lever Cover	PVC
12	Gasket	Steel
13	Lever Nut	Brass

Installation Dimensions

DN	d	L	L1	H	A	Weight(kg)
DN15	14	53	95	44	12	0.219
DN20	19	61	110	51	13	0.359
DN25	24	71	110	55	14.5	0.519
DN32	31	85	140	65	16.5	0.801
DN40	38	92	140	70	16.5	1.03
DN50	49	114	160	83	21	1.798

*Available in both connections standard BSPT & NPT



Specification

- Connection Standard: Threaded to ISO 7-1 BSPT, Available with NPT threading Model FBV-25N
- Test Standard: BS6755/ MSS SP-110
- Medium: water

Approval

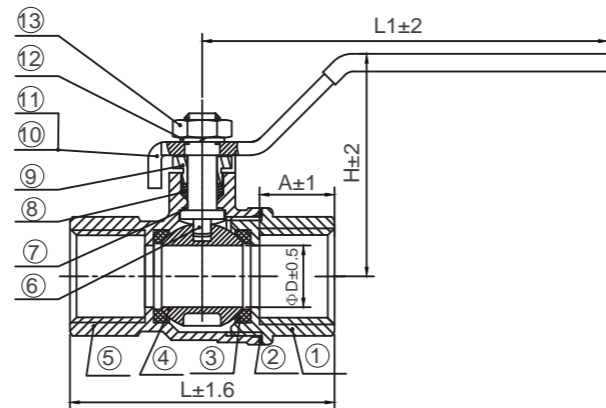

LF-FBV-EN-201906

Series LF-FBV

Bronze Ball Valve 2-Piece, Full Port

Size: DN15-DN50

The series LF-FBV Bronze Ball Valve is designed to be used for water, oil and gas, and also applies to aggressive media such as oxygen, hydrogen peroxide, methane, and ethylene, etc.

Features

- Suitable for a full range of liquids and gases
- Minimal pressure drop due to full-size ports
- Bottom loaded blowout proof stem
- Virgin PTFE stem packing seal, thrust washer and seat
- Vinyl insulator on heavy-duty zinc plated carbon steel handles
- Fast quarter-turn open or close operation
- Excellent for throttling and balancing application of non-abrasive fluids where the minimum flow is 20% to 100% of valve capacity
- Low operating torque
- Adjustable stem packing gland
- 600psi (41 bar) WOG, 125psi (8.6 bar) WSP

Pressure-Temperature

- Nominal Pressure: PN41
- Temperature Range: -18°C~177°C

Test Pressures

Pneumatic
Shell: 6bar
Seat: 6bar

Material

NO.	Component	Material
1	Body	Bronze
2	Seats	Virgin PTFE
3	Adaptor	Forged brass
4	Ball	Stainless Steel
5	Stem	Brass
6	Thrust Washer	Virgin PTFE
7	Stem Packing	Virgin PTFE
8	Packing Spacer	
9	Packing Nut	Brass
10	Handle	Zinc plated carbon steel with vinyl insulator
11	Handle Nut	Zinc plated carbon steel

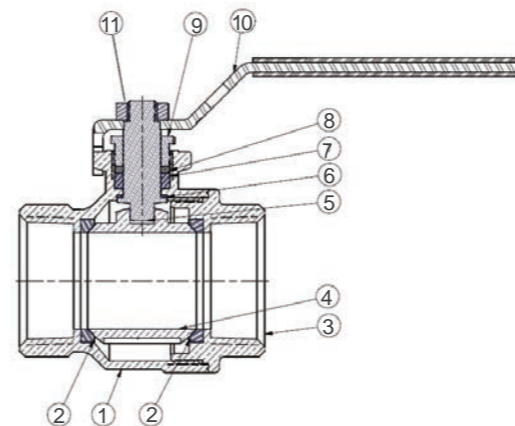

Specification

- Design standard: MSS SP-110
- Connection Standard: Thread PTF to ANSI B1.20.3
- Test Standard: MSS SP-110
- Medium: water

Approval



Installation Dimensions

DN	H	C	L	A	T
DN15	79.5	38.2	50.2	29.3	1/2"-14 PTF-SAESHORT
DN20	84.5	45.9	60.5	40.8	3/4"-14 PTF-SAESHORT
DN25	84.5	54.6	72.7	50.3	1"-11.5 PTF-SAESHORT
DN32	128.6	72.3	81.2	60.8	1 1/4"-11.5 PTF-SAESHORT
DN40	148.6	81.1	89.9	70.3	1 1/2"-11.5 PTF-SAESHORT
DN50	163.4	89.0	104.5	87.3	2"-11.5 PTF-SAESHORT

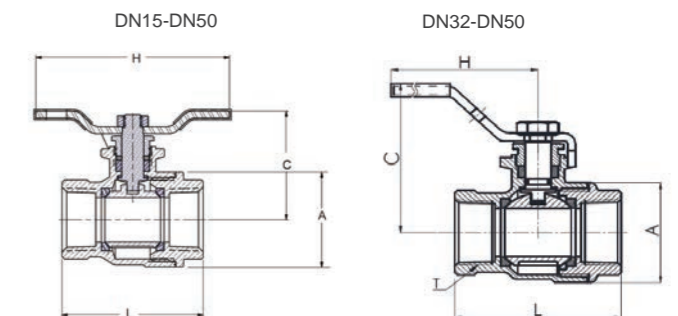

Characteristic Curve

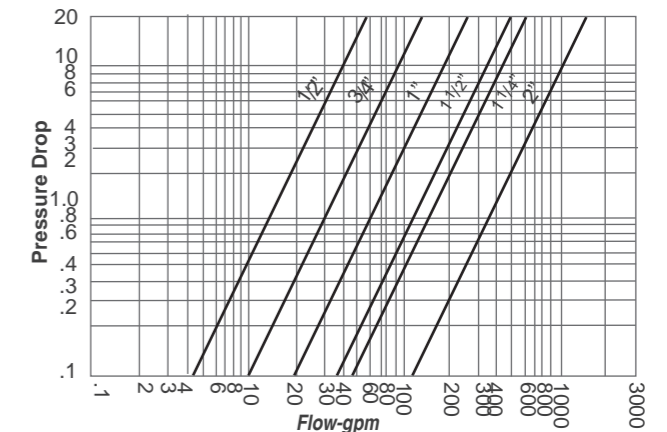



W-L-FBV-BSPT-EN-202206

Series W-L-FBV-BSPT

Broze Ball Valve 2-Piece, Full port

Size: DN15-DN50

The series W-L-FBV-BSPT Bronze Ball Valve is designed to be used for water, oil and gas, and also applies to aggressive media such as oxygen, hydrogen peroxide, methane and ethylene, etc.

Features

- Suitable for a full range of liquids and gases
- Minimal pressure drop due to full size ports
- Bottom loaded blowout proof stem
- Virgin PTFE stem packing seal, thrust washer and seat
- Vinyl insulator on heavy duty zinc plated carbon steel handles
- Fast quarter-turn open or close operation
- Excellent for throttling and balancing application of non-abrasive fluids where minimum flow is 20% to 100% of valve capacity
- Low operating torque
- Adjustable stem packing gland
- 600psi (41 bar) WOG, 125psi (8.6 bar) WSP

Pressure - Temperature

- Nominal Pressure: PN41
- Temperature Range: -18°C ~ 177°C

Test Pressures

Pneumatic
Shell: 6bar
Seat: 6bar

Material

NO.	Component	Material
1	Body	Lead Free Bronze
2	Seats	Virgin PTFE
3	Adapter	Lead Free Bronze
4	Ball	Stainless Steel (SS304)
5	Stem	Brass
6	Thrust Washer	Virgin PTFE
7	Stem Packing	Virgin PTFE
8	Packing Spacer	
9	Packing Nut	Brass
10	Handle	Zinc plated carbon steel with vinyl insulator
11	Handle Nut	Zinc plated carbon steel

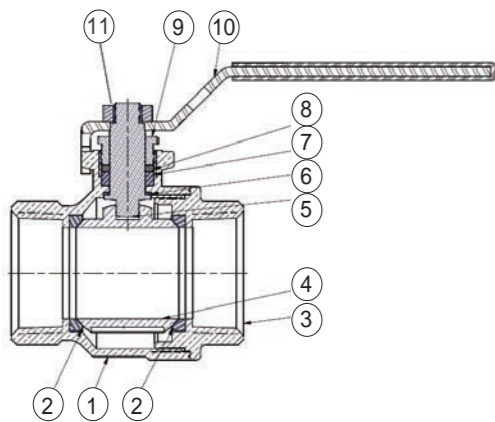

Specification

- Design Standard: MSS SP-110
- Connection Standard: Thread BSPT to ISO 7-1
- Test Standard: MSS SP-110
- Medium: water

Approval



Installation Dimensions

DN	H	C	L	A
DN15	79.5	38.2	50.2	29.3
DN20	84.5	45.9	60.5	40.8
DN25	84.5	54.6	72.7	50.3
DN32	128.6	72.3	81.2	60.8
DN40	148.6	81.1	89.9	70.3
DN50	163.4	89.0	104.5	87.3

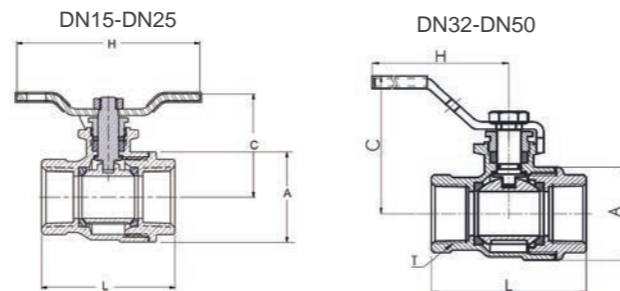

Characteristic Curve

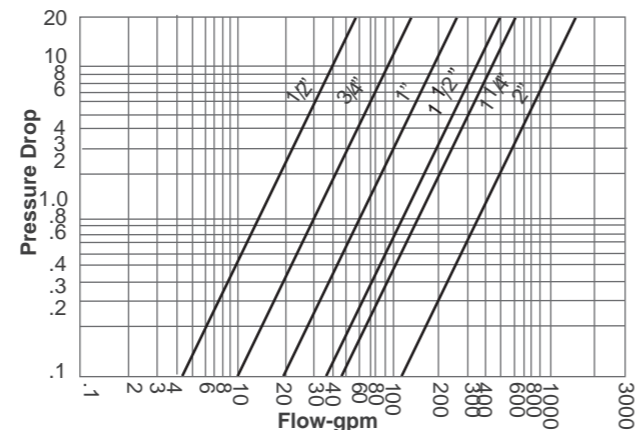

LFFBV-3C-M1-EN-202212

Series LFFBV-3C-M1

2-Piece, Full Port, Lead-Free Brass Ball Valve

Size: DN8-DN100

Series LFFBV-3C-M1 2-piece, full port, Lead-Free ball valves are used in commercial and industrial applications for a full range of liquids and gases. They feature a bottom-loaded blowout proof stem, virgin PTFE seats, thrust washer, and adjustable stem packing gland, stem packing nut, chrome plated Lead-Free brass ball, copper silicon alloy brass adapter, and steel handle. The Series LFFBV-3C-M1 features Lead-Free construction to comply with Lead-Free* installation requirements.

Features

- Lead-Free forged copper silicon alloy body and adapter
- Fluorocarbon elastomer stem O-ring prevents stem leaks
- Adjustable stem packing gland for easy maintenance
- PTFE stem packing seal, thrust washer, and seats for reliable performance
- Bottom loaded blowout proof stem
- Available with stem extension

Pressure-Temperature

- Nominal Pressure: PN41 (1/4"-2"); PN27 (2 1/2"-4")
- Temperature Range: -40°C~204°C

Material

No.	Component	Material
A	Handle Nut	Zinc plated carbon steel
B	Handle Assembly	Zinc plated carbon steel with vinyl insulator
C	Packing Nut	Brass
D	Stem Packing	Virgin PTFE
E	O-ring	Fluorocarbon elastomer (FKM)
F	Thrust Washer	Virgin PTFE (for the 2" - 4")
G	Stem	Brass
H	Tag	Cardboard, Mylar coated both sides
I	Body	Forged Lead Free* copper silicon alloy WTS-LLB
J	Seats	Virgin PTFE
K	Ball	Chrome plated Lead Free* brass
L	Adapter	Forged Lead Free* copper silicon alloy brass

Installation Dimension

SIZE	DIMENSIONS												WEIGHT	
	C		H		H1		I		L		L1		Threaded	
in.	in.	mm	in.	mm	in.	mm	in.	mm	in.	mm	in.	mm	in.	mm
1/4	1 ¹³ / ₁₆	46	3 ⁷ / ₁₆	87	-	-	1/2	13	2	48	-	-	0.4	0.2
3/8	1 ¹³ / ₁₆	46	3 ⁷ / ₁₆	87	-	-	1/2	13	2	48	-	-	0.4	0.2
1/2	1 ¹³ / ₁₆	46	3 ⁷ / ₁₆	87	3 ⁷ / ₁₆	87	1/2	13	2 ³ / ₈	61	2 ¹ / ₁₆	52	0.4	0.2
3/4	2 ¹ / ₄	53	4 ¹ / ₁₆	103	4 ¹ / ₁₆	103	3/4	18	2 ⁷ / ₁₆	62	2 ¹ / ₂	66	0.7	0.3
1	2 ³ / ₈	60	4 ¹ / ₄	108	4 ¹ / ₄	108	1 ⁵ / ₁₆	24	3 ¹ / ₁₆	77	3 ¹ / ₄	83	1.2	0.5
1 1/4	2 ¹ / ₂	64	4 ¹ / ₄	108	4 ¹ / ₄	108	1 1/4	31	3 ⁹ / ₁₆	85	3 ³ / ₄	93	1.6	0.7
1 1/2	3	76	5 ¹ / ₄	135	5 ⁵ / ₁₆	135	1 1/2	37	3 ³ / ₄	93	4 ¹ / ₄	107	2.4	1.1
2	3 ¹ / ₂	89	6	152	6	152	1 ¹⁵ / ₁₆	50	4 ¹ / ₈	108	5 ¹ / ₄	135	4.0	1.8
2 1/2	4 ¹ / ₁₆	103	7 ³ / ₈	187	7 ³ / ₈	187	2 1/2	64	5 ¹ / ₂	140	6 ¹ / ₄	158	8.3	3.8
3	4 ¹ / ₂	114	7 ³ / ₄	197	7 ³ / ₄	197	3	75	6 ⁵ / ₁₆	161	7 ³ / ₈	184	12.5	5.7
4	5 ³ / ₈	136	9 ⁵ / ₈	245	-	-	4	102	7 ⁵ / ₈	194	-	-	23.3	10.6



Specification

- Design Standard: MSS-SP-110
- Connection Standard: NPT to ASME B1.20.1
- Threaded valves 1/4"-2" shall be CSA approved to 1/2, 5, and 125psig (14, 34 and 862 kPa), UL/FM approved and 1/4"- 4" certified to NSF/ANSI standard 61/8
- Solder valves 1/2" - 2" to be UL listed FM approved, and certified to NSF/ANSI standard 61/8.

Test Pressures

Pneumatic
Shell: 6 bar
Seat: 6 bar

Approvals

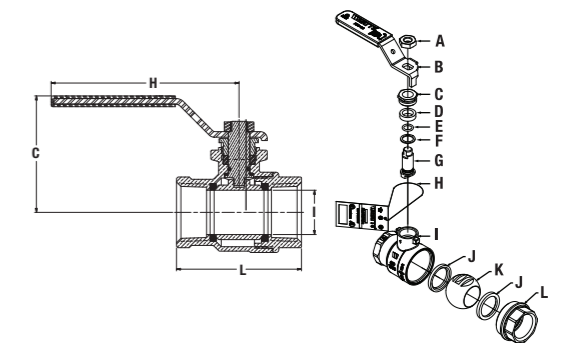



FBV-3C-EN-202206

Series FBV-3C

Brass Ball Valve

Size: DN8-DN100

Series FBV-3C 2-piece, full port, brass ball valves are used in commercial and industrial applications for a full range of liquids and gases. They feature a bottom-loaded blowout proof stem, virgin PTFE seats, thrust washer, and adjustable stem packing gland, stem packing nut, chrome-plated brass ball, brass adapter, and steel handle.

Features

- Compact structure, reliable sealing
- Simple structure, convenient maintenance
- In the closed state, sealing surface and spherical is not easily to erode by media
- Convenient operation, quick opening, and closing, easy to maintenance
- Unrestricted media flow direction
- Small fluid resistance
- UL/FM Certified

Pressure-Temperature

- Nominal Pressure: PN41 (1/4"-2"); PN27 (2 1/2"-4")
- Temperature Range: -40°C~204°C

Material

No.	Component	Material
A	Handle Nut	Zinc plated carbon steel
B	Handle Assembly	Zinc plated carbon steel with vinyl insulator
C	Packing Nut	Brass
D	Stem Packing	Virgin PTFE
E	O-ring	Fluorocarbon elastomer (FKM)
F	Thrust Washer	Virgin PTFE
G	Stem	Brass
H	Tag	Cardboard, Mylar coated both sides
I	Body	Forged Brass
J	Seats	Virgin PTFE
K	Ball	Chrome plated brass
L	Adapter	Forged Brass

Characteristic Curve

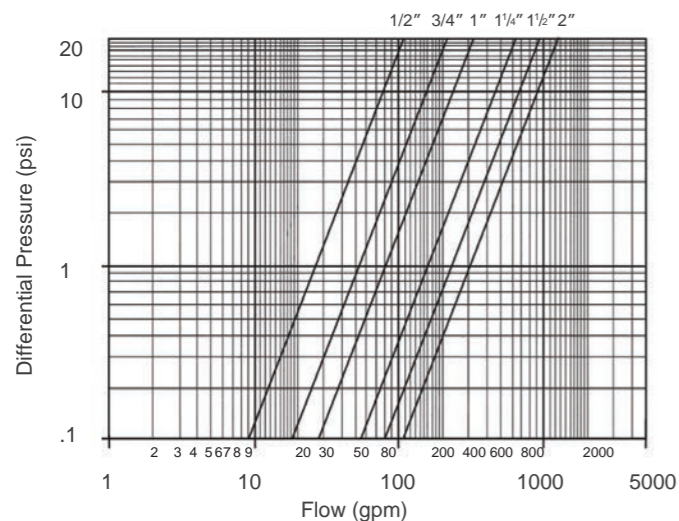

Specification

- Design Standard: MSS-SP-110
- Connection Standard: NPT to ASME B1.20.1
- CSA approved threaded valves only 1/4" - 3" (15 - 80mm)
- UL/FM approved threaded valves 1/4" - 2" (8 - 50mm)
- UL Listed solder valves 1/2" - 2" (15 - 50mm)

Test Pressures

Pneumatic
Shell: 6 bar
Seat: 6 bar

Approvals

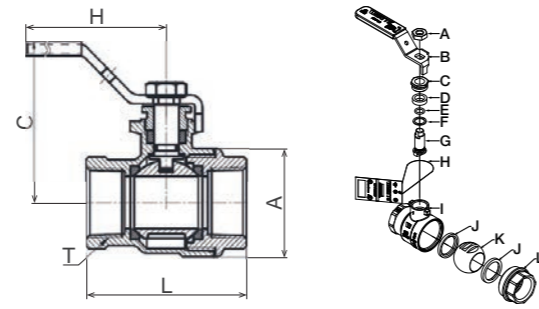

Installation Dimensions

Size	H	C	L	A	T
DN8	86.9	45.9	44.7	28.4	1/4
DN10	86.9	46	44.7	28.4	3/8
DN15	86.9	45.9	49.8	28.4	1/2
DN20	100.8	57.4	59.4	39.6	3/4
DN25	108.2	67.1	71.9	46.2	1
DN32	108.2	71.3	80.6	57.4	1-1/4
DN40	135	80.2	88.4	67.6	1-1/2
DN50	153.1	89.4	105.2	85.7	2
DN65	186.8	103.5	134.4	107.7	2-1/2
DN80	196.6	114.1	153.8	127.8	3
DN100	244.83	135.9	188	167.1	4



R6001/R6001N-EN-202212

Series R6001/R6001N

Brass Ball Valve

Size: DN15-DN100

The Watts R6001/R6001N Brass Ball Valve is light compact design, easy to install and operate. The series is designed to be used for water application.

Features

- Light, compact, and easy to install and operate
- Minimal pressure drop due to full size ports
- Low operating torque

Pressure - Temperature

- Nominal Pressure: PN16
- Temperature Range: -10°C~110°C

Test Pressures

Pneumatic	Hydraulic
Shell: 6 bar	Shell: 24bar
Seat: 6 bar	Seat: 17.6 bar

Material

NO.	Component	Material
1	Bonnet	Brass
2	Seal	PTFE
3	Ball	Brass
4	Body	Brass
5	Spindle	Brass
6	O-Ring	EPDM
7	Handle	Steel
8	Nut	Stainless Steel

Installation Dimensions

Size DN(mm)	Dimensions(mm)						Wt.(kg)
	A	B	L	(E)	(F)	G*	
15	10	10.5	52	43.5	86	1/2"	0.16
20	14	12	57	48.5	114	3/4"	0.26
25	19	15	67	52	114	1"	0.37
32	24	17	78	61	131	1-1/4"	0.65
40	30	17	87	69	159	1-1/2"	0.84
50	38	21.5	106	76	159	2"	1.37
65	49	25.7	131	84.5	159	2-1/2"	2.29
80	60	26.5	143	114.6	225.5	3"	3.66
100	85	32	184	133.1	225.5	4"	6.98

* Available in both connections standard BSPT & NPT



Specification

- Connection Standard: BSPT to ISO 7-1, NPT to ASME B1.20.1
- Test Standard: BS EN 12266-1/ MSS SP-110
- Medium: water

Approval

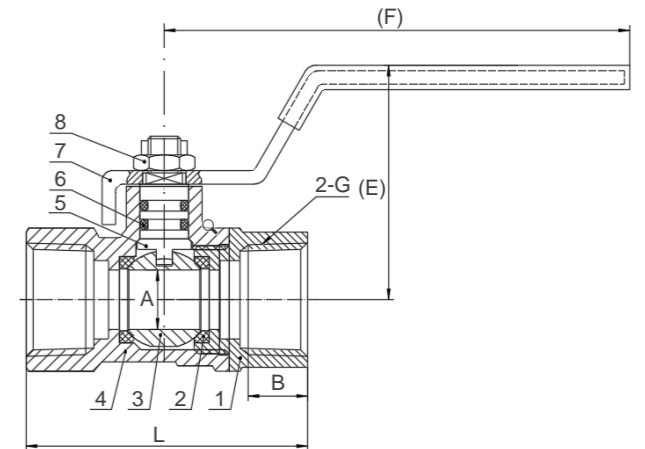



286W/287W-EN-202005

Series 286W

PN25 Brass Ball Valve with Female BSP Connections

Series 287W

PN25 Brass Ball Valve with Combination Male & Female BSP Connections

Size: DN8 - DN50

Features

- Watermark & Gas Safety approved
- Bottom loaded blowout proof stem
- Machined chrome plated brass ball
- Full port design
- Lever handle standard, options of locking and butterfly handles

Pressure – Temperature

- Nominal Pressure: Fluids 25 bar (2500 kPa)
Gas 25 bar (2500 kPa)
- Working Temperature: Fluids 0°C ~ 95°C
Gas 0°C ~ 50°C

Typical Application

Watts Series 286W & 287W Ball valves are designed for isolation service in Plumbing, HVAC and common liquid services compatible with the materials of construction. With Watermark approval they are ideal for potable domestic water and commercial installations.

Material

NO.	Component	Material
1	Body	DZR Brass
2	Bonnet	DZR Brass
3	Ball	DZR Brass, Chrome Plated
4	Seat	PTFE
5	Stem	DZR Brass
6	O-ring (Series 286W)	EP7118F
	O-ring (Series 287W)	EPDM
7-1	Handle	Carbon Steel, PVC Covering
7-2	Handle Locking Device	Carbon Steel
7-3	Butterfly Handle	Aluminum
8	Hex Nut	S.S.



Specification

- Connections
Series 286W female BSP to AS3688
Series 287W combination male & female BSP to AS3688
- Test Standard: WMTS012: 2018
- Working Medium: Non corrosive liquids and gas

Approval



WM040213

- Gas Safety Approved. License No: GAS-104839-001

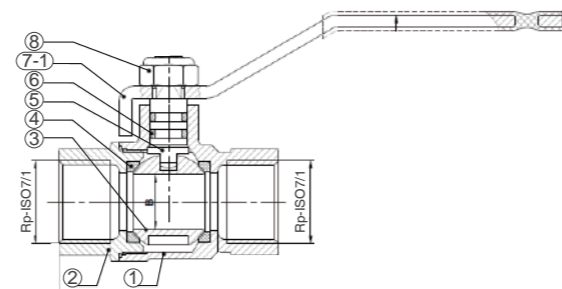

Series 286W

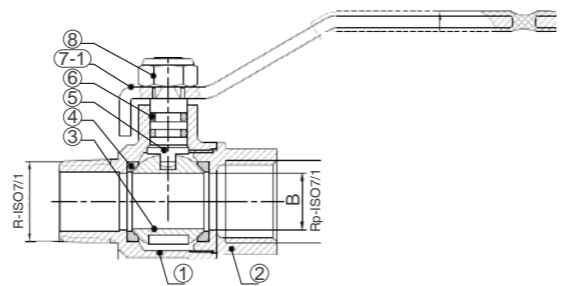

Series 287W



286W/287W-EN-202005

Installation Dimensions

Series 286W Female Threaded Valve, Lever, Locking and Butterfly Handle

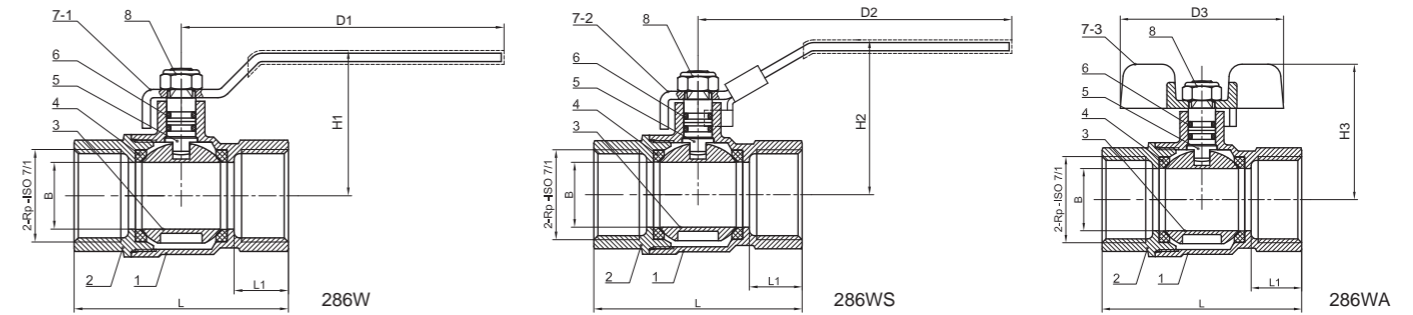

Size		L	L1	H1	H2	H3	D1	D2	D3	B(Core)
in	mm									
1/2"	15	56	15.5	42.3	48.3	39.5	101	101	50	14
3/4"	20	66	17	48.8	53.8	47.5	116	116	63	19
1"	25	77	19.5	52.3	57.3	52	116	116	63	24
1 1/4"	32	92	22	77.3	72.8	-	141	146	-	31
1 1/2"	40	103	22	82.8	78.3	-	141	146	-	38
2"	50	120	26	90.3	91.8	-	166	166	-	49

Series 287W Male & Female Threaded Valve, Lever, Locking and Butterfly Handle

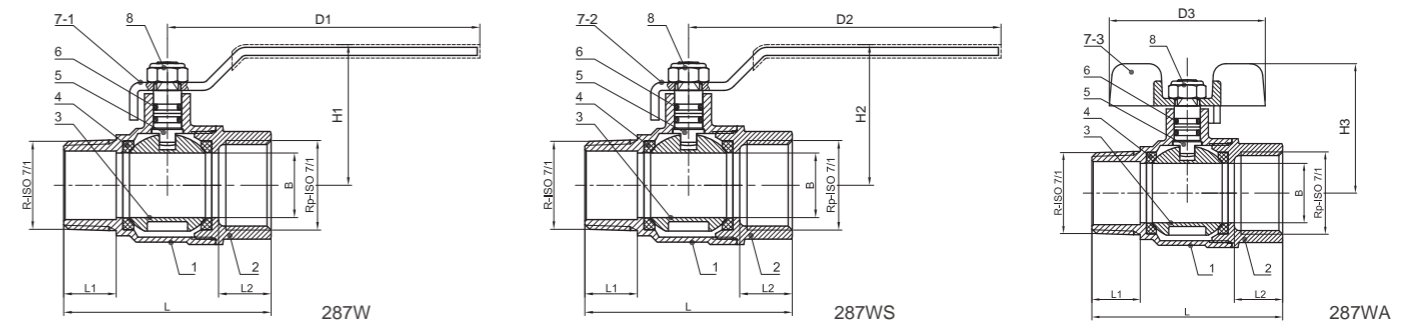

Size		L	L1	L2	H1	H2	H3	D1	D2	D3	B(Core)
in	mm										
1/2"	15	56	15	15.5	42.3	48.3	39.5	96	101	50	14
3/4"	20	65	16.5	17	48.8	53.8	47.5	116	116	63	19
1"	25	77	19.5	19.5	52.3	57.3	52	116	116	63	24
1 1/4"	32	92	22	22	77.3	72.8	-	141	146	-	31
1 1/2"	40	103	22	22	82.8	78.3	-	141	146	-	38
2"	50	120	26	26	90.3	91.8	-	166	166	-	49

Note: For DN8, DN10, please contact Watts sales representatives.

Installation Instructions

1. Ensure the operating line pressure, temperature and fluid type is compatible with the valve's ratings and materials of construction
2. Plumbing installers working on potable water systems must ensure they meet state licensing requirements
3. Flush the pipework prior to installation of the valve to ensure all dirt and foreign material is removed
4. Use only AS4020 compliant thread sealants, when used on potable water installations
5. Not suitable for use on any hydrocarbon service due to the presence of EPDM O-ring seals



290-EN-202206

Series 290

Drain Valve

Size: DN10-DN20

This valve is particularly indicated for shutting off generally non-corrosive fluids that are compatible with the valve materials. An excellent field of application is in plant engineering for plumbing, heating & cooling systems.

Features

- Male tapered drain valve with fly nut, pipe and cap
- Finish: sandblasted brass finishing

Pressure-Temperature

- Nominal Pressure: PN10
- Maximum Temperature: -10°C~90°C

Material

NO.	Component	Material
1	Body	Brass
2	Nut	Brass
3	Cone	Brass
4	Shutter	Plastic
5	Gasket	SGL Carbon
6	Fly Nut	Brass
7	Pipe Gasket	NBR
8	Hose Connection	Brass
9	Chain	Brass Iron
10	Cap	Brass
11	Cap Gasket	NBR

Installation Dimensions

Part No.	A	B	C	R	DN	PN
29038	3/8"	73	28	1/2"	8	10
29012	1/2"	75	32	3/4"	10	10
29034	3/4"	92	38	1"	13.5	10



Specification

- Connection Standard: threaded to ISO228

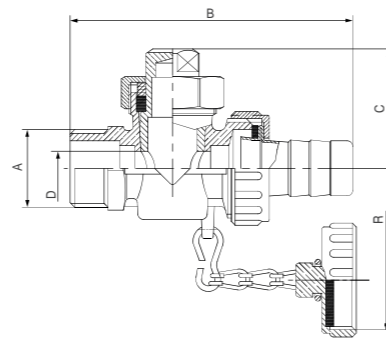
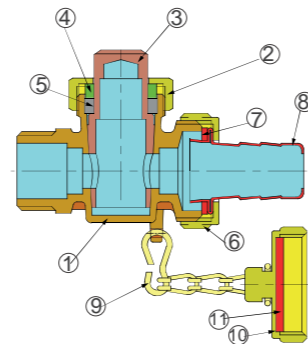

W-W1911-L/G-EN-202212

Series W-W1911-L/G

Lug- Type Butterfly Valve

**Size: DN50-DN150(-L) Lever operated
DN50-DN600(-G) Gear operated**

The Watts SeriesW-W1911 butterfly valves are designed and manufactured to meet the stringent requirements of plumbing, HVAC, irrigation, commercial and industrial application.

Features

- Simple structure, easy to operate
- Simple installation, excellent sealing performance.
- High reliability and long durability
- Position indicators
- Double regulating feature available on request

Pressure - Temperature

- Nominal Pressure: PN16
- Temperature Range: -20 C ~120 C

Test Pressures

Shell: 24bar
Seat: 17.6bar

Material

Component	Material
Body	Ductile Iron
Disc	Stainless Steel (SS316) Aluminum Bronze* Ductile Iron (Nickel-plated) Ductile Iron (Epoxy coated)
Seat	EPDM
Stem	Stainless Steel (SS420)

*Contact sales for Aluminum Bronze disc dimensions

Installation Dimensions

1. Lug-type lever operated midline butterfly valve (W-W1911-L ME)

DN	H1	H2	H3	H4	L	L1	□C	D1	n×m	α	D2	D3	D4	n×φd	Torque(N.m)	
															Wet	Dry
50	80	142.7	95	24	215	43	□9	φ 125	4×M16	45°	φ 89	φ 51.7	φ 70	4×φ 10	15.1	24.2
65	89	155.4	95	24	215	46	□9	φ 145	4×M16	45°	φ 105	φ 63.3	φ 70	4×φ 10	17.2	32.7
80	95	161.8	95	24	215	46	□9	φ 160	8×M16	22.5°	φ 120	φ 77.7	φ 70	4×φ 10	23.1	43.7
100	114	177	95	26	215	52	□11	φ 180	8×M16	22.5°	φ 148	φ 103.1	φ 70	4×φ 10	39.8	72.8
125	127	189.5	95	26	215	56	□14	φ 210	8×M16	22.5°	φ 170	φ 122.2	φ 70	4×φ 10	61.9	108
150	139	204.2	95	26	215	56	□14	φ 240	8×M20	22.5°	φ 203	φ 154.9	φ 70	4×φ 10	102	174

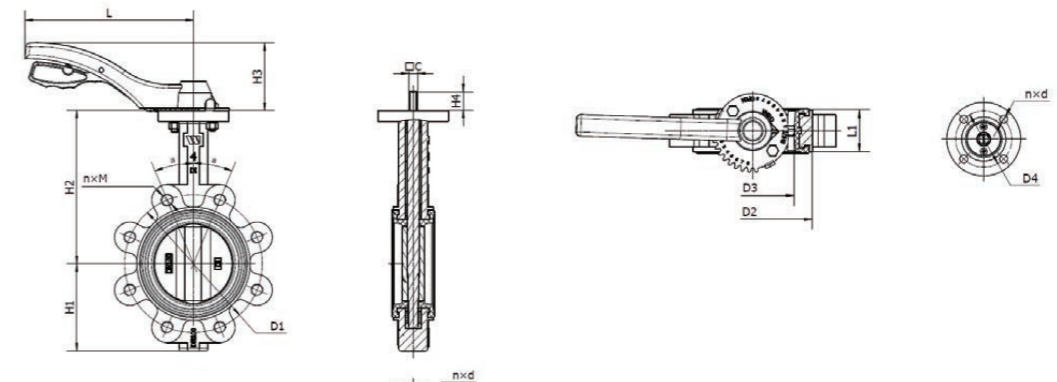

Specification

- Design Standard: EN 593, BS 5155/ MSS-SP-67
- Connection Standard: ISO7005-2:1998
BS EN1092:2-1997 PN16
- Test Standard: BS EN12266-1
- Connection Type: Lug Type
- Medium: water

Approval



2. Lug-type gear operated midline butterfly valve (W-W1911-G ME)

DN	H1	H2	H3	H4	φ E	L1	□C/D5	b	D1	n×m	α	D2	D3	D4	n×φ d	Torque(N.m)	
																Wet	Dry
50	62	136	66	24	150	43	□9	-	φ 125	4×M16	45°	φ 89	φ 51.7	φ 70	4X φ 10	15.1	24.2
65	70	145	66	24	150	46	□9	-	φ 145	4×M16	45°	φ 105	φ 63.3	φ 70	4X φ 10	17.2	32.7
80	89	151	66	24	150	46	□9	-	φ 160	8×M16	22.5°	φ 120	φ 77.7	φ 70	4X φ 10	23.1	43.7
100	106	170	66	26	150	52	□11	-	φ 180	8×M16	22.5°	φ 148	φ 103.1	φ 70	4X φ 10	39.8	72.8
125	119	190	66	26	150	56	□14	-	φ 210	8×M16	22.5°	φ 170	φ 122.2	φ 70	4X φ 10	61.9	108
150	131	203	66	26	150	56	□14	-	φ 240	8×M20	22.5°	φ 203	φ 154.9	φ 70	4X φ 10	102	174
200	164	245.5	82	26	298	60	□17	-	φ 295	12×M20	15°	φ 255	φ 201.3	φ 102	4X φ 12	192	330
250	199	271	82	26	298	68	□22	-	φ 355	12×M24	15°	φ 303	φ 249.4	φ 102	4X φ 12	323	549
300	230	296	84	26	298	78	□22	-	φ 410	12×M24	15°	φ 355	φ 300.1	φ 102	4X φ 12	490	799
350	288	368	84	40	298	78	φ 31.6 ^{+0.05}	8	φ 470	16×M24	11.25°	φ 405	φ 331.5	φ 102	4X φ 14	625	969
400	331	400	120	52	300	102	φ 33.15 ^{+0.05}	10	φ 525	16×M27	11.25°	φ 470	φ 387.5	φ 140	4X φ 18	846	1307
450	355	422	120	52	300	114	φ 38 ^{+0.05}	10	φ 585	20×M27	9°	φ 525	φ 438.5	φ 140	4X φ 18	1131	1787
500	388	480	150	64	300	127	φ 41.15 ^{+0.05}	10	φ 650	20×M30	9°	φ 578	φ 488.8	φ 140	4X φ 18	1431	2288
600	475	562	150	70	300	154	φ 50.65 ^{+0.05}	16	φ 770	20×M33	9°	φ 693	φ 589.9	φ 165	4X φ 22	2301	3711

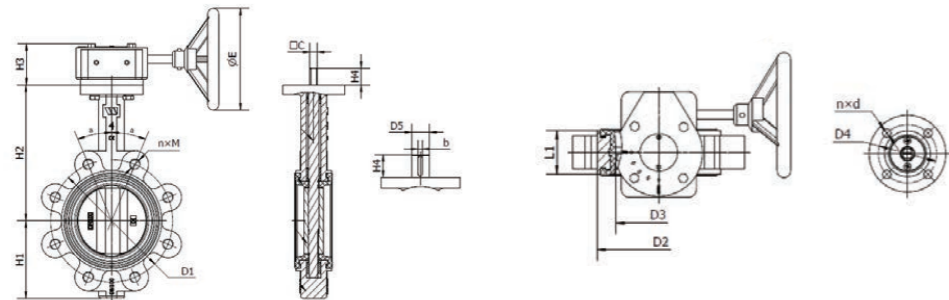

Characteristic Curves

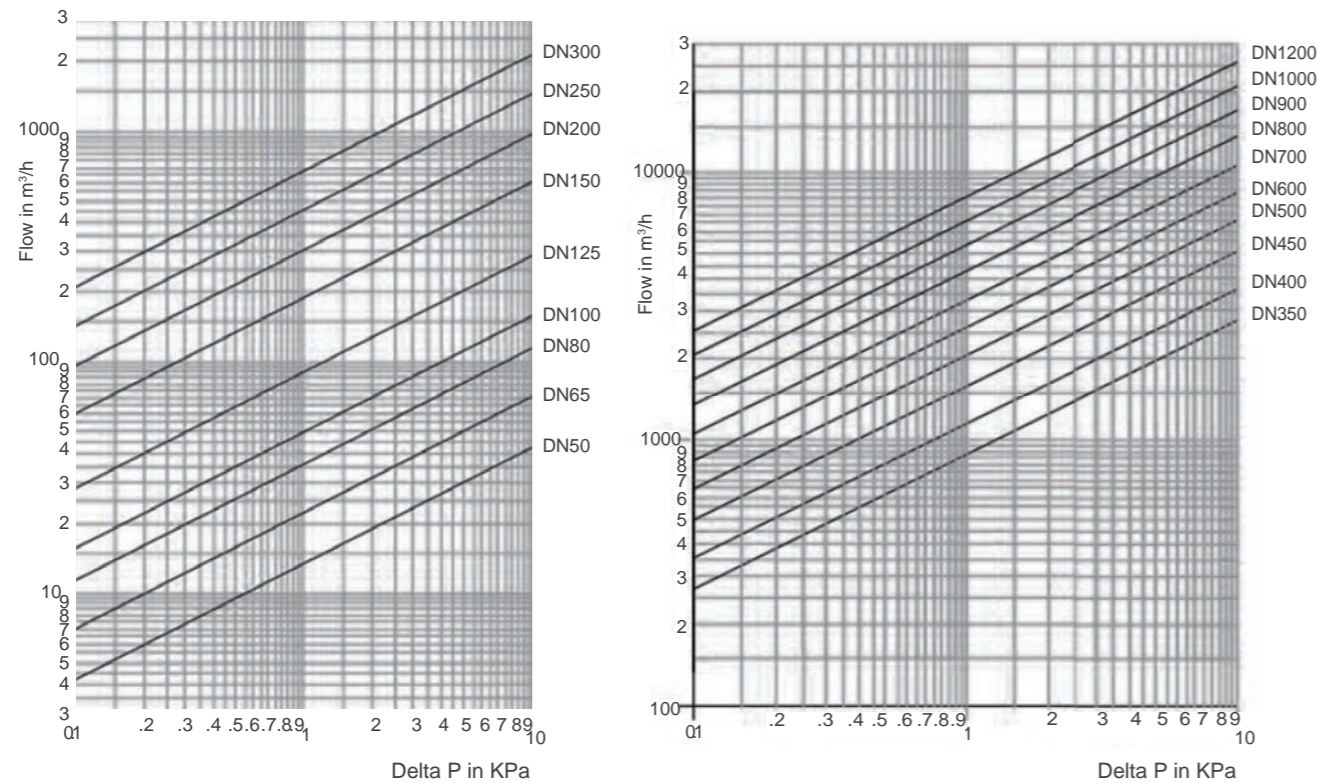

Series W-W1924-L/G-ME

Lug-Type Butterfly Valve

Size: DN50-DN150(-L)
DN50-DN600(-G)

The Watts Series W-W1924 butterfly valves are designed and manufactured to meet the stringent requirements of plumbing, HVAC, irrigation, commercial and industrial application.

Features

- Simple structure, easy to operate
- Simple installation, excellent sealing performance
- High reliability and long durability
- Position indicators
- Double regulating feature available on request

Pressure - Temperature

- Nominal Pressure: PN25
- Temperature Range: -20°C~120°C

Test Pressures

- Shell: 37.5 bar
- Seat: 27.5 bar

Material

Component	Material
Body	Ductile Iron
Disc	Stainless Steel(SS316) Aluminum Bronze Ductile Iron(Nickel-plated) Ductile Iron(Epoxy coated)
Seat	EPDM
Stem	Stainless Steel

Installation Dimensions

1. Lug-type lever operated midline butterfly valve (W-W1924-L-ME)

DN	H1	H2	H3	H4	L	L1	C	D1	n×M	α	D2	D3	D4	n×φ D	Torque(N.m)	
															Wet	Dry
50	62	136	95	24	215	43	9	φ 125	4XM16	45°	φ 89	φ 51.7	φ 70	4X φ 10	20.4	32.7
65	70	145	95	24	215	46	9	φ 145	8XM16	45°	φ 105	φ 63.3	φ 70	4X φ 10	23.2	44.1
80	89	151	95	24	215	46	9	φ 160	8XM16	22.5°	φ 120	φ 77.7	φ 70	4X φ 10	31.19	59
100	106	170	95	26	215	52	11	φ 190	8XM20	22.5°	φ 148	φ 103.1	φ 70	4X φ 10	53.7	98.3
125	119	190	95	26	215	56	14	φ 220	8XM24	22.5°	φ 170	φ 122.2	φ 70	4X φ 10	83.6	145.8
150	131	203	95	26	215	56	14	φ 250	8XM24	22.5°	φ 203	φ 154.9	φ 70	4X φ 10	137.7	234.9

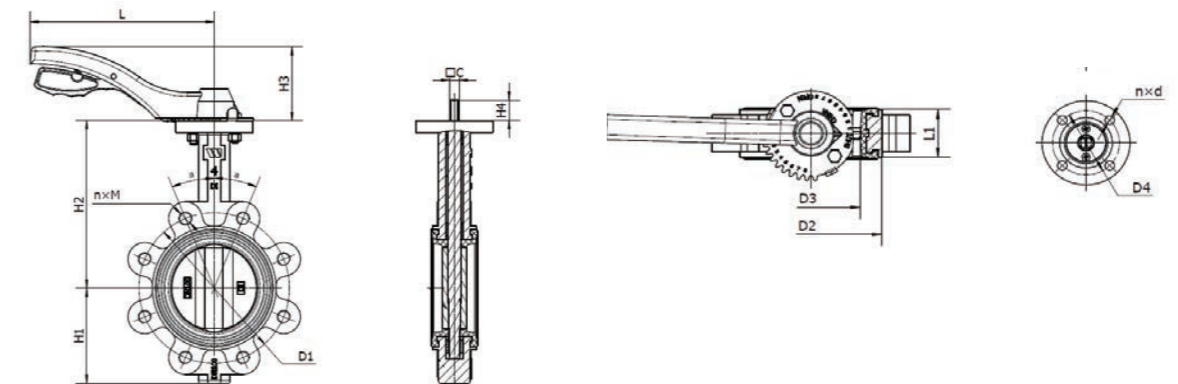



BF-03-EN-202212

Series BF-03

Lug-Type Butterfly Valve

Size: DN50-DN600

The Watts Series BF-03 butterfly valves are designed and manufactured to meet the stringent requirements of plumbing, HVAC, irrigation, commercial and industrial application.

Features

- Simple structure, easy to operate
- Simple installation, excellent sealing performance
- High reliability and long durability
- Position indicators

Pressure - Temperature

- Nominal Pressure: DN50~DN300 200PSI(13.8bar)
DN350-DN600 150PSI(10.3bar)
- Working Temperature: -20°C~120°C

Test Pressures

Size	Pneumatic	Hydraulic
DN50~DN300	Seat:15.2 bar	Shell:20.7 bar
DN350~DN600	Seat:11.3 bar	Shell:15.4 bar

Material

Component	Material
Body	Ductile Iron Cast Iron
Disc	Stainless Steel Aluminum Bronze Ductile Iron (Nickel-plated) Ductile Iron (Epoxy coated)
Seat	EPDM
Stem	Stainless Steel

Specification

- Design Standard: MSS-SP-67
- Test Standard: ISO5208:2008
- Connection Standard: ANSI B16.1
- Connection Type: Lug Type
- Nominal Diameter: DN50~DN125 Lever
DN150~DN600 Gear
- Medium: water



Characteristic Curves

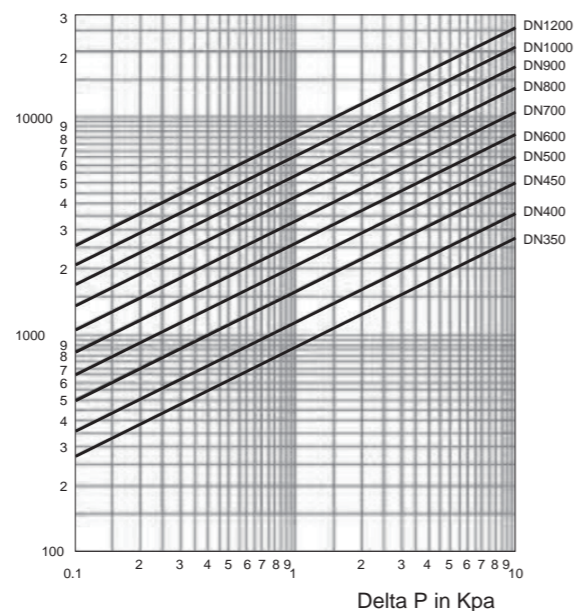
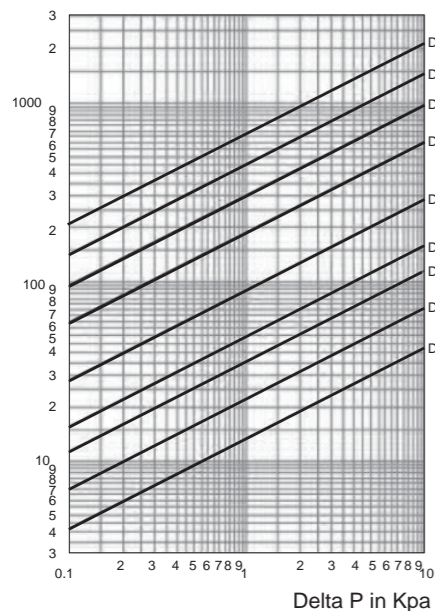

BF-03-EN-202212

Installation Dimensions

1. Lug-type lever operated midline butterfly valve (BF-03-15)

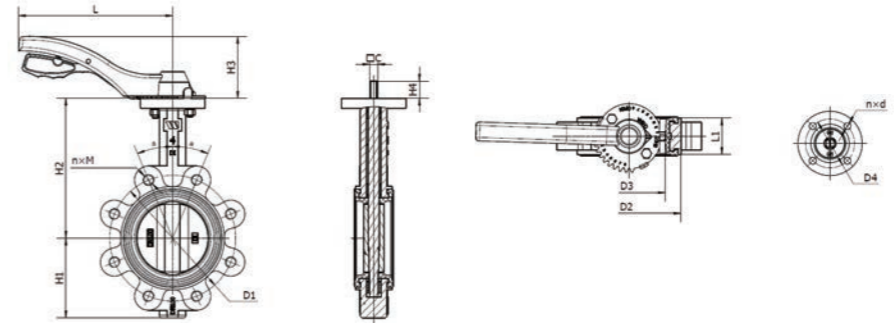

DN	H1	H2	H3	H4	L	L1	□C	D1	n x M	D2	D3	D4	n x φ d	Torque(N.m)	
														Wet	Dry
50	80	161	66	24	215	43	□8.86	Φ121	4X5/8"-11UNC	Φ89	Φ51	Φ50	4XΦ7	134	214
65	89	264	66	24	215	46	□8.86	Φ140	4X5/8"-11UNC	Φ108	Φ62.8	Φ50	4XΦ7	190	289
80	95	181	66	24	215	46	□8.86	Φ150	4X5/8"-11UNC	Φ120	Φ77.3	Φ50	4XΦ7	250	387
100	114	200	66	26	215	52	□11.1	Φ191	8X5/8"-11UNC	Φ150	Φ102.5	Φ70	4XΦ9	390	644
125	127	213	66	26	215	56	□12.7	Φ216	8X3/4"-10UNC	Φ181	Φ121.8	Φ70	4XΦ9	600	959

2. Lug-type gear operated midline butterfly valve (BF-03-1G)

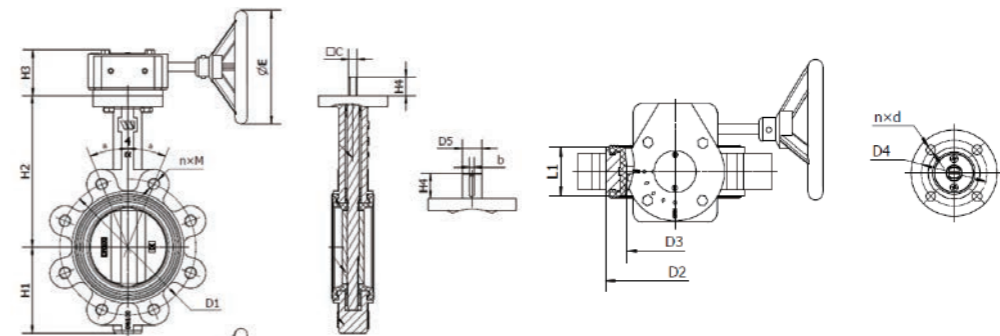

DN	H1	H2	H3	H4	L1	φE	□C/D5	b	D1	n x M	D2	D3	D4	n x φ d	Torque(in.-lbs.)	
															Wet	Dry
50	80	161	66	24	43	150	□8.86	-	Φ121	4X5/8"-11UNC	Φ89	Φ51	Φ50	4XΦ7	134	214
65	89	264	66	24	46	150	□8.86	-	Φ140	4X5/8"-11UNC	Φ108	Φ62.8	Φ50	4XΦ7	190	289
80	95	181	66	24	46	150	□8.86	-	Φ150	4X5/8"-11UNC	Φ120	Φ77.3	Φ50	4XΦ7	250	387
100	114	200	66	26	52	150	□11.1	-	Φ191	8X5/8"-11UNC	Φ150	Φ102.5	Φ70	4XΦ9	390	644
125	127	213	66	26	56	150	□12.7	-	Φ216	8X3/4"-10UNC	Φ181	Φ121.8	Φ70	4XΦ9	600	959
150	139	226	66	26	56	150	□12.7	-	Φ241	8X3/4"-10UNC	Φ208	Φ154.2	Φ70	4XΦ9	907	1,542
200	175	260	82	33	60	298	□15.88	-	Φ298	8X3/4"-10UNC	Φ260	Φ200.9	Φ102	4XΦ11	1,697	2,919
250	203	292	82	26	68	298	□20.62	-	Φ362	12X7/8"-9UNC	Φ320	Φ248.9	Φ102	4XΦ11	2,500	4,857
300	242	337	84	26	78	298	Φ31.6	6.32	Φ432	12X7/8"-9UNC	Φ375	Φ299.9	Φ125	4XΦ13	3,300	7,071
350	267	368	84	40	78	298	Φ31.6	6.32	Φ476	12X1"-8UNC	Φ405	Φ331.7	Φ125	4XΦ13	3,500	7,305
400	297	400	120	52	102	300	Φ33.15	7.95	Φ540	16X1"-8UNC	Φ470	Φ387.5	Φ140	4XΦ18	5,500	10,027
450	315	422	120	52	114	300	Φ37.95	9.55	Φ578	16X1 1/8"-7UNC	Φ521	Φ438.4	Φ140	4XΦ18	8,200	13,437
500	348	480	150	64	127	300	Φ41.12	9.58	Φ635	20X1 1/8"-7UNC	Φ565	Φ489.6	Φ165	4XΦ22	10,000	17,925
600	444	562	150	70	154	300	Φ50.62	12.73	Φ750	20X1 1/4"-7UNC	Φ693	Φ590.1	Φ165	4XΦ22	18,680	28,020

Series W-W1111-L/G

Wafer-Type Butterfly Valve

Size: DN50-DN150(-L) Lever operated
DN50-DN600(-G) Gear operated

The Watts Series W-W1111 butterfly valves are designed and manufactured to meet the stringent requirements of plumbing, HVAC, irrigation, commercial and industrial application.

Features

- Simple structure, easy to operate
- Simple installation, excellent sealing performance.
- High reliability and long durability
- Position indicators
- Double regulating feature available on request

Pressure - Temperature

- Nominal Pressure: PN16
- Temperature Range: -20°C ~ 120°C

Test Pressures

Shell: 24bar
 Seat: 17.6bar

Material

Component	Material
Body	Ductile Iron
Disc	Stainless Steel (SS316) Aluminum Bronze* Ductile Iron (Nickel-plated) Ductile Iron (Epoxy coated)
Seat	EPDM
Stem	Stainless Steel (SS420)

*Contact sales for Aluminum Bronze disc dimensions

Installation Dimensions

1. Wafer-type lever operated midline butterfly valve (W-W1111-L)

DN	H1	H2	H3	H4	L1	L	C	D1	n x φ	α	D2	D3	D4	n x φ d	D6	H5	Torque (N.m)	
																	Wet	Dry
50	68	142.7	95	24	43	215	9	φ 125	4x φ 19	45°	φ 89	φ 51.7	φ 70	4x φ 10	φ 92	12	15.1	24.2
65	77	155.4	95	24	46	215	9	φ 145	4x φ 19	45°	φ 105	φ 63.3	φ 70	4x φ 10	φ 92	13	17.2	32.7
80	89	161.8	95	24	46	215	9	φ 160	4x φ 19	22.5°	φ 120	φ 77.7	φ 70	4x φ 10	φ 92	14	23.1	43.7
100	103	177	95	26	52	215	11	φ 180	4x φ 19	22.5°	φ 148	φ 103.1	φ 70	4x φ 10	φ 92	14	39.8	72.8
125	119	189.5	95	26	56	215	14	φ 210	4x φ 19	22.5°	φ 170	φ 122.2	φ 70	4x φ 10	φ 92	14	61.9	108
150	133	204.2	95	26	56	215	14	φ 240	4x φ 23	22.5°	φ 203	φ 154.9	φ 70	4x φ 10	φ 92	14	102	174

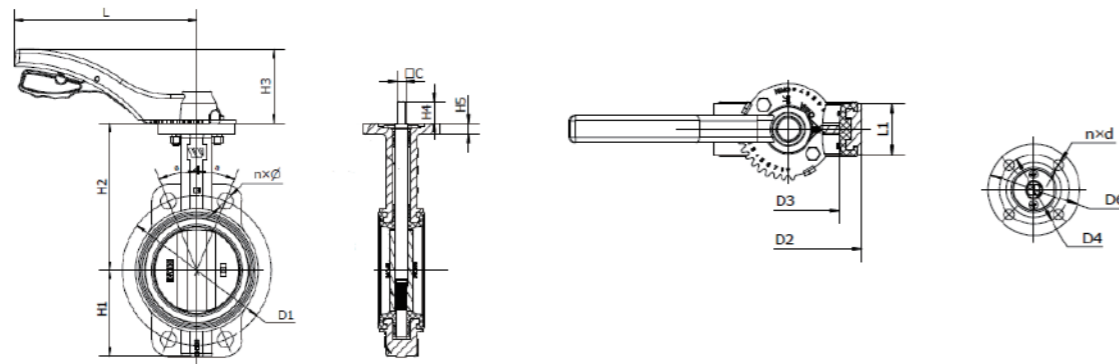

Specification

- Design Standard: EN 593, BS 5155/ MSS-SP-67
- Connection Standard: ISO7005-2:1998
BS EN1092-2:1997 PN16
- Test Standard: BS EN12266-1
- Connection Type: Wafer Type
- Medium: water

Approval



2. Wafer-type gear operated midline butterfly valve (W-W1111-G)

DN	H1	H2	H3	H4	L1	φ E	C	D1	α	D2	D3	D4	n x φ d	Torque (N.m)	
														Wet	Dry
50	62	136	66	24	43	150	□9	φ 125	45°	φ 89	φ 51.7	φ 70	4X φ 10	15.1	24.2
65	70	145	66	24	46	150	□9	φ 145	45°	φ 105	φ 63.3	φ 70	4X φ 10	17.2	32.7
80	89	151	66	24	46	150	□9	φ 160	22.5°	φ 120	φ 77.7	φ 70	4X φ 10	23.1	43.7
100	106	170	66	26	52	150	□11	φ 180	22.5°	φ 148	φ 103.1	φ 70	4X φ 10	39.8	72.8
125	119	190	66	26	56	150	□14	φ 210	22.5°	φ 170	φ 122.2	φ 70	4X φ 10	61.9	108
150	131	203	66	26	56	150	□14	φ 240	22.5°	φ 203	φ 154.9	φ 70	4X φ 10	102	174
200	164	245.5	82	33	60	298	□17	φ 295	15°	φ 255	φ 201.3	φ 102	4X φ 12	192	330
250	199	271	82	26	68	298	□22	φ 355	15°	φ 303	φ 249.4	φ 102	4X φ 12	323	549
300	230	296	84	26	78	298	□22	φ 410	15°	φ 355	φ 300.1	φ 102	4X φ 12	490	799
350	288	368	84	40	78	298	φ 31.6	φ 470	11.25°	φ 436	φ 331.5	φ 102	4X φ 14	625	969
400	331	400	120	52	102	300	φ 33.15	φ 525	11.25°	φ 488	φ 387.5	φ 140	4X φ 18	846	1307
450	355	422	120	52	114	300	φ 38	φ 585	9°	φ 536	φ 438.5	φ 140	4X φ 18	1131	1787
500	388	480	150	64	127	300	φ 41.15	φ 650	9°	φ 593	φ 488.8	φ 140	4X φ 18	1431	2288
600	475	562	150	70	154	300	φ 50.65	φ 770	9°	φ 820	φ 589.9	φ 165	4X φ 22	2301	3711

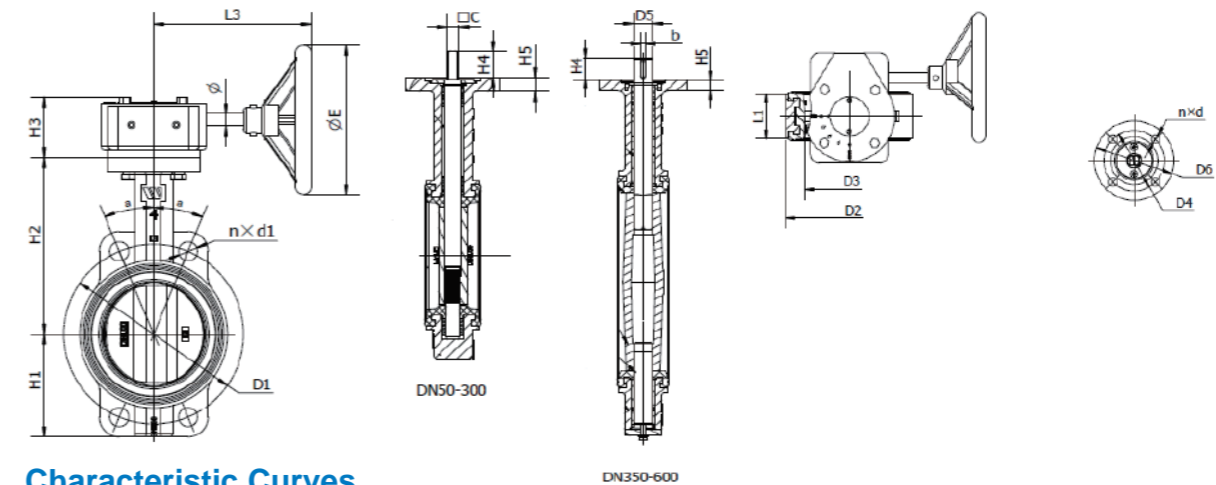

Characteristic Curves

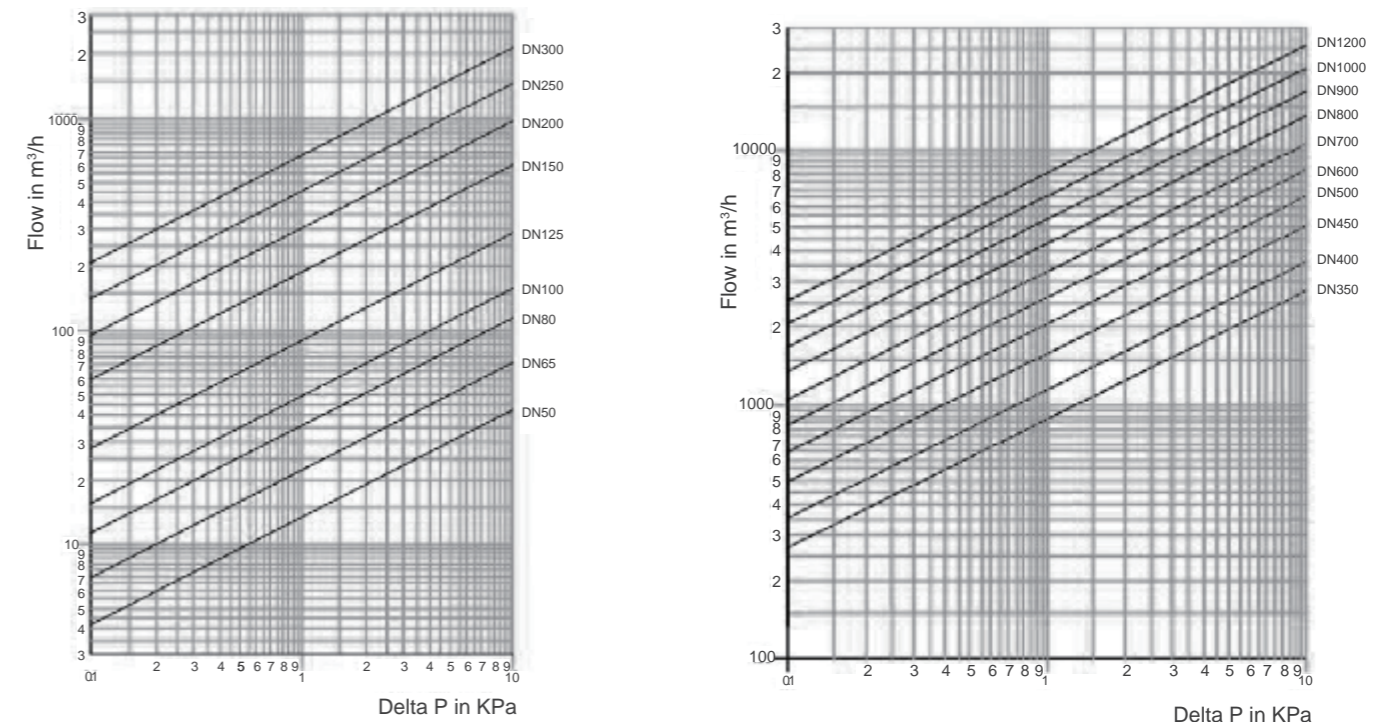



W-W1124-L/G-EN-202212

Series W-W1124-L/G

Wafer-Type Butterfly Valve

**Size: DN50-DN150 (-L)
DN50-DN600 (-G)**

The Watts Series W-W1124 butterfly valves are designed and manufactured to meet the stringent requirements of Plumbing, HVAC, Irrigation, Commercial and Industrial applications.

Features

- Simple structure, easy to operate
- Simple installation, excellent sealing performance
- High reliability and long durability
- Position indicators

Pressure - Temperature

- Nominal Pressure: PN25
- Working Temperature: -20°C~120°C

Test Pressures

Shell: 37.5 bar
Seat: 27.5 bar

Material

Component	Material
Body	Ductile Iron
Disc	Stainless Steel(SS316) Aluminum Bronze Ductile Iron (Nickel-plated) Ductile Iron (Epoxy coated)
Seat	EPDM
Stem	Stainless Steel(SS316)

Characteristic Curves

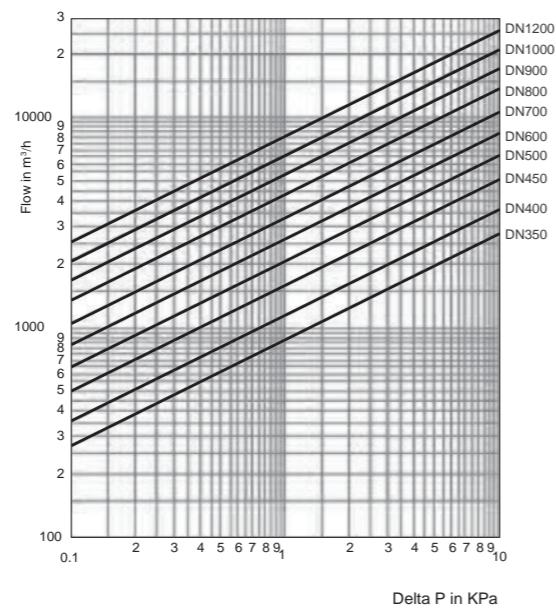
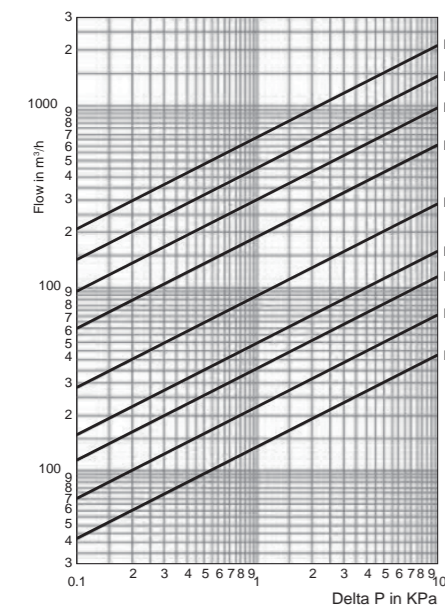

Specification

- Connection Standard: ISO7005-2:1998/ MSS SP-67
BS EN1092:2-1997 PN 25
- Nominal Diameter: DN50~DN150 Lever
DN50~DN600 Gear
- Connection Type: Wafer Type
- Medium: water



W-W1124-L/G-EN-202212

Installation Dimensions

1. Wafer-type lever operated midline butterfly valve (W-W1124-L)

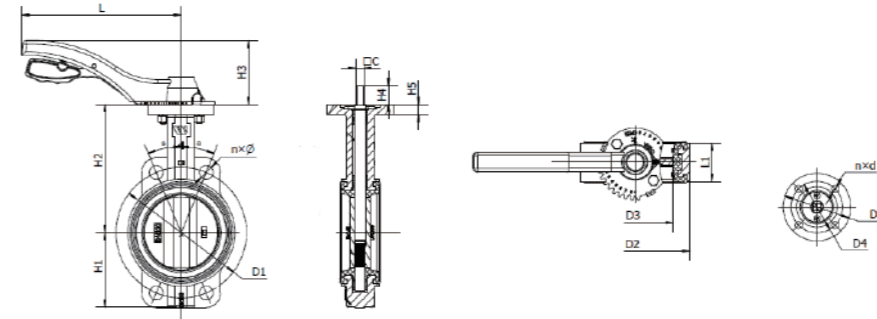

DN	H1	H2	H3	H4	L	L1	C	D1	n×Φ	α	nxD1	D2	D3	D4	n×φd	D6	H5	Torque(N.m)	
																		Wet	Dry
50	80	161	66	24	215	48	9	Φ 125	4x Φ 18	45°	4-Φ 18	Φ 89	Φ 51.7	Φ 70	4x Φ 10	Φ 92	12	20.4	32.7
65	89	175	66	24	215	50	9	Φ 145	4x Φ 18	45°	4-Φ 18	Φ 105	Φ 63.3	Φ 70	4x Φ 10	Φ 92	13	23.2	44.1
80	95	181	66	24	215	50	9	Φ 160	4x Φ 18	22.5°	4-Φ 18	Φ 120	Φ 77.7	Φ 70	4x Φ 10	Φ 92	14	31.19	59
100	114	200	66	26	215	56	11	Φ 190	4x Φ 23	22.5°	4-Φ 23	Φ 148	Φ 103.1	Φ 70	4x Φ 10	Φ 92	14	53.7	98.3
125	127	213	66	26	215	60	14	Φ 220	4x Φ 28	22.5°	4-Φ 28	Φ 170	Φ 122.2	Φ 70	4x Φ 10	Φ 92	14	83.6	145.8
150	144	226	66	26	215	60	14	Φ 250	4x Φ 28	22.5°	4-Φ 28	Φ 203	Φ 154.9	Φ 70	4x Φ 10	Φ 92	14	137.7	234.9

2. Wafer-type gear operated midline butterfly valve (W-W1124-G)

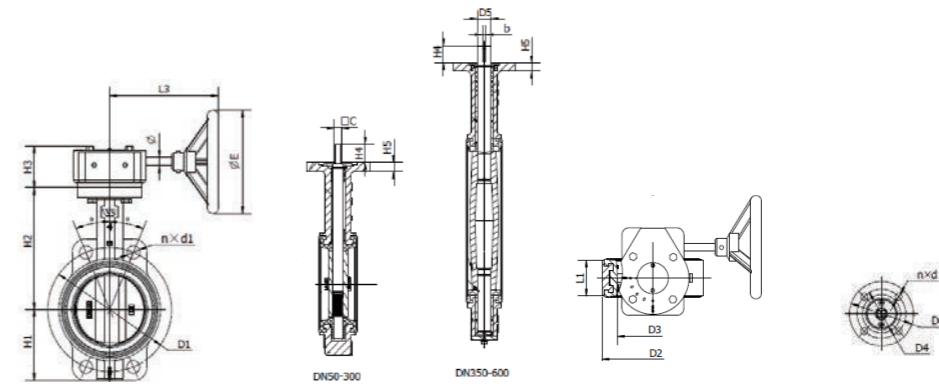

DN	H1	H2	H3	H4	L1	ΦE	C	b	D1	a	nxD1	D2	D3	D4	n×φd	Torque(in.-lbs.)	
																Wet	Dry
50	80	161	66	24	48	150	9	-	Φ 125	45°	4-Φ 18	Φ 89	Φ 51.7	Φ 70	4X Φ 10	20.4	32.7
65	89	175	66	24	50	150	9	-	Φ 145	45°	4-Φ 18	Φ 105	Φ 63.3	Φ 70	4X Φ 10	23.2	44.1
80	95	181	66	24	50	150	9	-	Φ 160	22.5°	4-Φ 18	Φ 120	Φ 77.7	Φ 70	4X Φ 10	31.19	59
100	114	200	66	26	56	150	11	-	Φ 190	22.5°	4-Φ 23	Φ 148	Φ 103.1	Φ 70	4X Φ 10	53.7	98.3
125	127	213	66	26	60	150	14	-	Φ 220	22.5°	4-Φ 28	Φ 170	Φ 122.2	Φ 70	4X Φ 10	83.6	145.8
150	144	226	66	26	60	150	14	-	Φ 250	22.5°	4-Φ 28	Φ 203	Φ 154.9	Φ 70	4X Φ 10	137.7	234.9
200	185	260	82	33	64	298	22	-	Φ 310	15°	4-Φ 28	Φ 263	Φ 201.3	Φ 102	4X Φ 12	259	446
250	211	292	82	26	72	298	22	-	Φ 370	15°	4-Φ 31	Φ 310	Φ 249.4	Φ 102	4X Φ 12	436	741
300	247	337	84	26	83	298	27	-	Φ 430	15°	4-Φ 31	Φ 363	Φ 300.1	Φ 125	4X Φ 14	662	1078
350	280	368	84	40	83	298	Φ 33.15 ^{0-0.05}	10	Φ 490	11.25°	4-Φ 34	Φ 410	Φ 331.5	Φ 140	4X Φ 18	844	1308
400	315	400	120	52	108	300	Φ 38 ^{0-0.05}	10	Φ 550	11.25°	4-Φ 37	Φ 474	Φ 387.5	Φ 140	4X Φ 18	1142	1764
450	345	422	120	52	120	300	Φ 38 ^{0-0.05}	10	Φ 600	9°	4-M33	Φ 525	Φ 438.5	Φ 140	4X Φ 18	1527	2412
500	373	480	150	64	133	300	Φ 50.65 ^{0-0.05}	16	Φ 660	9°	4-M33	Φ 578	Φ 488.8	Φ 165	4X Φ 23	1932	3089
600	449	562	150	70	160	300	Φ 63.55 ^{0-0.05}	2-18	Φ 770	9°	4-M36	Φ 693	Φ 589.9	Φ 165	4X Φ 22	3106	5010



BF-04-EN-202212

Series BF-04

Wafer-Type Butterfly Valve

Size: DN50-DN600

The Watts Series BF-04 butterfly valves are designed and manufactured to meet the stringent requirements of plumbing, HVAC, irrigation, commercial and industrial applications.

Features

- Simple structure, easy to operate
- Simple installation, excellent sealing performance
- High reliability and long durability
- Position indicators

Pressure - Temperature

- Nominal Pressure: DN50~DN300 200PSI(13.8bar)
DN350-DN600 150PSI(10.3bar)
- Working Temperature: -15°C~120°C

Test Pressures

DN50~DN300	DN350~DN600
Hydraulic	Hydraulic
Shell: 20.7 bar	Shell: 15.4 bar
Seat: 15.2 bar	Seat: 11.3 bar

Material

Component	Material
Body	Ductile Iron Cast Iron
Disc	Stainless Steel Aluminum Bronze Ductile Iron (Nickel-plated) Ductile Iron (Epoxy coated)
Seat	EPDM
Stem	Stainless Steel

Specification

- Design Standard: MSS-SP-67
- Connection Standard: ANSI B16.1
- Test Standard: ISO5208:2008
- Medium: water
- Connection Type: Wafer Type
- Nominal Diameter: DN50~DN125 Lever
DN150~DN600 Gear



Chart

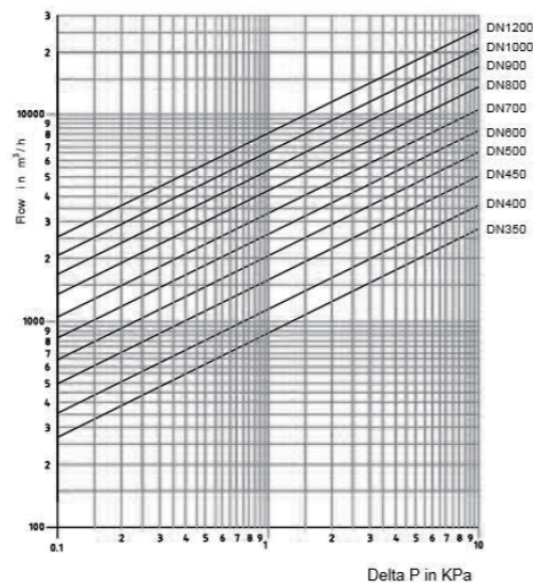
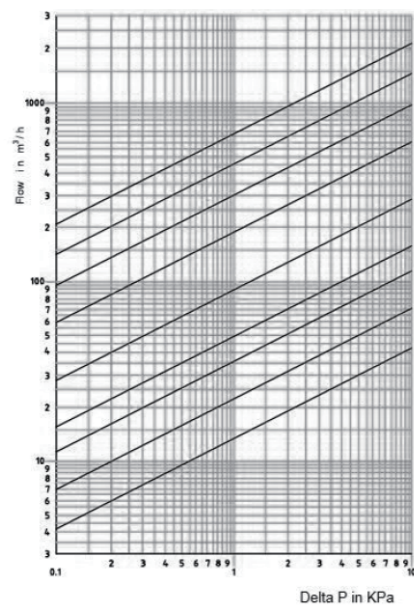

BF-04-EN-202212

Installation Dimensions:

1. Wafer-type lever operated midline butterfly valve (BF-04-15)

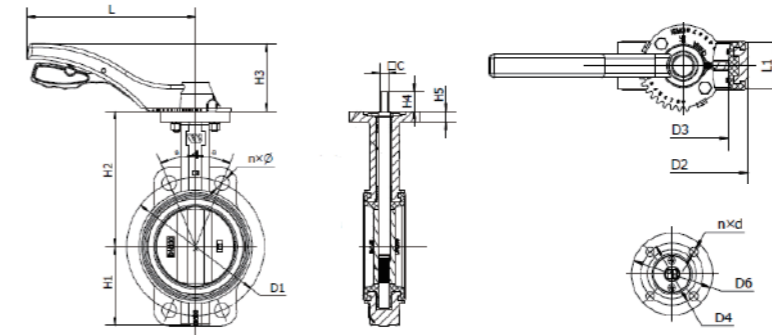

DN	H1	H2	H3	H4	L1	L	□C	D1	n x φ	D2	D3	D4	n x φ d	Torque(N.m)	
														Wet	Dry
50	80	161	66	24	46.1	215	□8.86	Φ121	4xΦ19	Φ89	Φ51	Φ50	4XΦ7	134	214
65	89	264	66	24	49.1	215	□8.86	Φ140	4xΦ19	Φ108	Φ62.8	Φ50	4XΦ7	190	289
80	95	181	66	24	48.4	215	□8.86	Φ150	4xΦ19	Φ120	Φ77.3	Φ50	4XΦ7	250	387
100	114	200	66	26	55.3	215	□11.1	Φ191	4xΦ19	Φ150	Φ102.5	Φ70	4XΦ9	390	644
125	127	213	66	26	58.8	215	□12.7	Φ216	4xΦ22.2	Φ181	Φ121.8	Φ70	4XΦ9	600	959

2. Wafer-type gear operated midline butterfly valve (BF-04-1G)

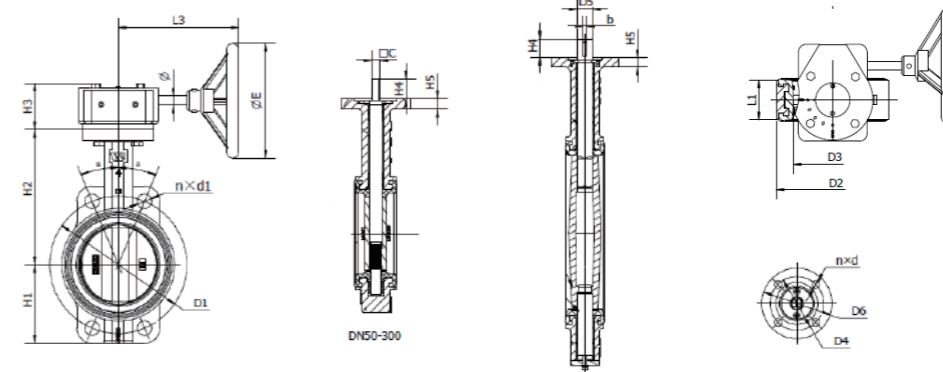

DN	H1	H2	H3	H4	L1	φE	□C/D5	b	D1	Nxd1	D2	D3	D4	n x φ d	Torque(in.-lbs.)	
															Wet	Dry
50	80	161	66	24	46.1	150	□8.86	-	Φ121	4xΦ19	Φ89	Φ51	Φ50	4XΦ7	134	214
65	89	264	66	24	49.1	150	□8.86	-	Φ140	4xΦ19	Φ108	Φ62.8	Φ50	4XΦ7	190	289
80	95	181	66	24	48.4	150	□8.86	-	Φ150	4xΦ19	Φ120	Φ77.3	Φ50	4XΦ7	250	387
100	114	200	66	26	55.3	150	□11.1	-	Φ191	4xΦ19	Φ150	Φ102.5	Φ70	4XΦ9	390	644
125	127	213	66	26	58.8	150	□12.7	-	Φ216	4xΦ22.2	Φ181	Φ121.8	Φ70	4XΦ9	600	959
150	139	226	66	26	59.1	150	□12.7	-	Φ241	4xΦ22.2	Φ208	Φ154.2	Φ70	4XΦ9	907	1,542
200	175	260	82	33	64.1	298	□15.88	-	Φ298	4xΦ22.2	Φ260	Φ200.9	Φ102	4XΦ11	1,697	2,919
250	203	292	82	26	71.8	298	□20.62	-	Φ362	4xΦ25.4	Φ320	Φ248.9	Φ102	4XΦ11	2,500	4,857
300	242	337	84	26	81	298	Φ31.6	6.32	Φ432	4xΦ25.4	Φ375	Φ299.9	Φ125	4XΦ13	3,300	7,071
350	267	368	84	40	79.5	298	Φ31.6	6.32	Φ476	4xΦ27	Φ405	Φ331.7	Φ125	4XΦ13	3,500	7,305
400	297	400	120	52	90	300	Φ33.15	7.95	Φ540	4xΦ27	Φ470	Φ387.5	Φ140	4XΦ18	5,500	10,027
450	315	422	120	52	109	300	Φ37.95	9.55	Φ578	4xΦ31.8	Φ521	Φ438.4	Φ140	4XΦ18	8,200	13,437
500	348	480	150	64	135	300	Φ41.12	9.58	Φ635	4xΦ31.8	Φ565	Φ489.6	Φ165	4XΦ22	10,000	17,925
600	444	562	150	70	156	300	Φ50.62	12.73	Φ750	20xΦ35	Φ693	Φ590.1	Φ165	4XΦ22	18,680	28,020



YG11-20/ 20N-EN-202208

Series YG11-20/ 20N

Bronze Y-Type Strainer

Size: DN15-DN50

The Watts YG11-20 Bronze Strainer is designed to remove impurities in the medium to protect valve and equipment for normal use. The Series is generally used in chilled water, potable water and other water treatment applications.

Features

- Low resistance
- Simple structure and convenient installation & cleaning
- Large pollutant-holding volume and convenient pollutant discharge
- Easy to install and to operate

Pressure-Temperature

- Nominal Pressure: PN20
- Temperature Range: 0 °C ~ 170 °C

Test Pressures

Pneumatic	Hydraulic
Shell: 6 bar	Shell: 30 bar
Shell: 6 bar	Seat: 22 bar

Material

NO.	Component	Material
1	Body	Bronze
2	Screen	Stainless Steel
3	Gasket	PTFE
4	Cap	Bronze
5	ID Plate	Aluminum

Installation Dimensions

DN	L	H	A	Weight(kg)
DN15	58	40	15	0.162
DN20	70	51	16.3	0.273
DN25	88	57.6	19.1	0.384
DN32	96	68.5	21.4	0.641
DN40	107	74	21.4	0.886
DN50	126	95	24	1.425

*Available in both connections standard BSPT & NPT

Screen Specifications

Meshes of Strainer for YG11-20/20N				
Spe.	Mesher/cm2	Thickness	Diameter of Hole	Free Area percentage
DN15	56-60	0.3-0.35	0.7-0.8	45-50%
DN20				
DN25	26-28	0.4	1.4	50-55%
DN32				
DN40				
DN50				



Specification

- Connection Standard: Threaded to ISO 7-1 BSPT. Available with NPT threading Model YG11-20N
- Test Standard: BS6755
- Medium: water

Approval

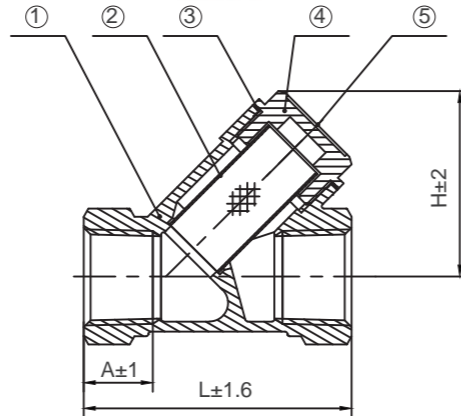

LF777S-EN-202208

Series LF777S, LFS777S

Wye-Pattern Lead Free* Bronze Strainer

Size: DN15-DN100

Series LF777S, LFS777S Wye-Pattern Lead Free* Bronze Strainers are designed to protect system components from dirt, rust and other damaging debris in the piping system. This series features a retainer cap tapped for closure plug. The LF777S and LFS777S feature Lead Free* construction to comply with Lead Free* installation requirements.

Features

- Lead Free* cast copper silicon alloy body
- Wye-pattern
- Retainer cap tapped for closure plug

Pressure-Temperature

- Maximum Working Pressure:
- ½" – 3" 400psi (27.6 bar) WOG @ 210°F (99°C) 125psi (8.6 bar) WSP @ 353°F (178°F)
 - 4" 300psi (20.7 bar) WOG @ 210°F (99°C) 125psi (8.6 bar) WSP @ 353°F (178°F)

Models

- LF777S ½" – 4" threaded connections
- LFS777S ½" – 2" solder connections

Material

Component	Material
Body	Lead Free* cast copper silicon alloy
Retainer Cap	½": Lead Free* copper silicon alloy ¾" – 4": Lead Free* cast copper silicon alloy
Cap Gasket	½" – 2": EPDM Other sizes consult factory
Standard Screen	½" – 2½": 304 stainless steel #20 mesh, 3": ¾" (1.2mm) 304 stainless steel perforated screen 4": 1/8" (3mm) 304 stainless steel perforated screen

Installation Dimensions

LF777S

SIZE (DN)	DIMENSIONS			WEIGHT
	A	B	C (NPT)	
mm	mm	mm	mm	kgs.
¼	68	43	10	0.77
¾	68	43	10	0.77
½	76	51	10	0.77
¾	84	59	15	0.77
1	114	59	20	1.22
1¼	130	79	20	1.36
1½	149	95	25	1.81
2	157	124	32	3.36
2½	206	125	32	5.44
3	257	170	40	10.90
4	325	267	40	18.60



LF777S

LFS777S

Characteristic Curve

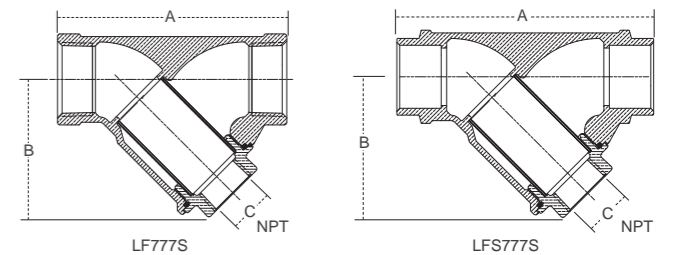
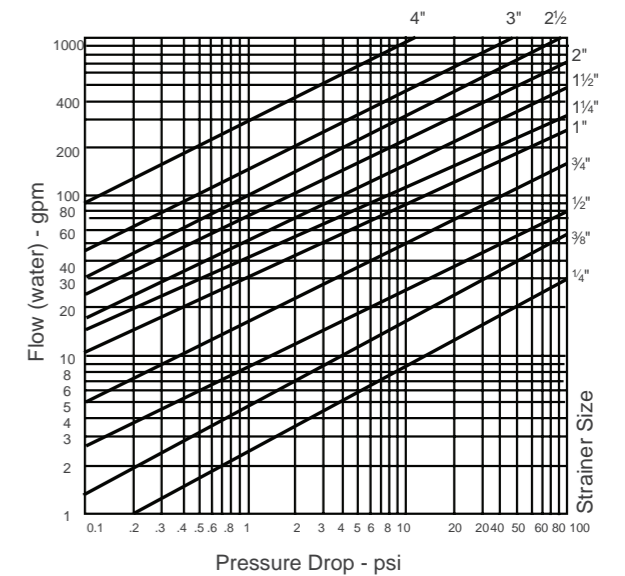

LFS777S

SIZE (DN)	DIMENSIONS			WEIGHT
	A	B	C (NPT)	
mm	mm	mm	mm	kgs.
½	86	52	10	0.68
¾	95	65	15	0.73
1	127	76	20	1.13
1¼	143	82	20	1.25
1½	164	97	25	1.81
2	191	118	32	3.39



R2001/R2001N-EN-202105

Series R2001/R2001N

Brass Y-Type Strainer

Size: DN15-DN50

The Watts R2001/R2001N Brass Strainer is designed to remove impurities in the medium to protect valve and equipment for normal use. The Series is generally used in building services, residential, etc.,

Features

- Low resistance
- Simple structure and convenient installation & cleaning
- Large pollutant-holding volume and convenient pollutant discharge
- Easy to install and to operate

Pressure - Temperature

- Nominal Pressure: PN16
- Temperature Range: -20°C~110°C

Test Pressures

Pneumatic	Hydraulic
Shell: 6 bar	Shell: 24 bar
Seat: 6 bar	Seat: 17.6 bar

Material

NO.	Component	Material	Standard
1	Body	Brass	CW617N
2	Filter	Stainless Steel	SUS304
3	Gasket	PTFE	
4	Bonnet	Brass	CW617N

Installation Dimensions

Size DN(mm)	Dimensions(mm)					Wt.(kg)
	A	H	L	G*	Mesh	
15	11	39.5	52	1/2"	14	0.14
20	11.5	45	60.5	3/4"	14	0.20
25	12	55.8	75	1"	14	0.21
32	13	65.8	80	1-1/4"	14	0.48
40	13.5	76.6	97	1-1/2"	14	0.68
50	16	90.6	121	2"	14	1.13

*Available in both connections standard BSPT & NPT



Specification

- Connection Standard: BSPT to ISO 7-1, NPT to ASME B1.20.1
- Test Standard: BS EN 12266-1
- Medium: water

Approval

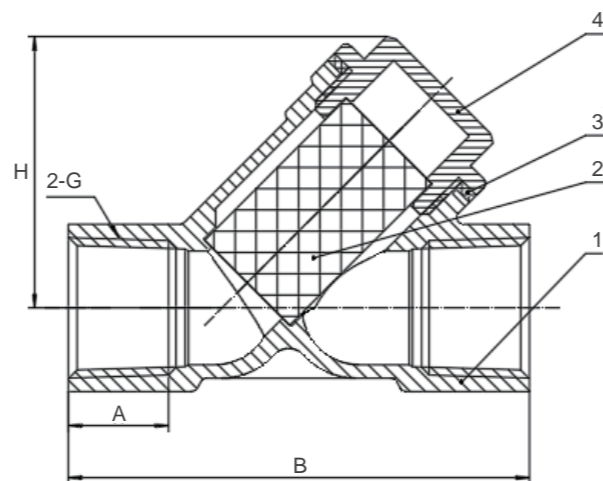

W-W4112-EN-202206

Series W-W4112

Ductile Iron Y Strainer

Size: Flange DN50-DN600

The Watts W-W4112 Y Strainer is designed to remove impurities in the medium to protect the valve and equipment for normal use. It's generally used in plumbing, HVAC, irrigation, commercial, and industrial application.

Features

- Low-pressure drop
- Simple structure and convenient to clean
- Large impuring holding capacity
- Other screen perforation size available

Pressure - Temperature

- Nominal Pressure: PN16
- Working Temperature: 0°C~120°C

Test Pressures

Hydraulic
Shell: 24 bar
Seat: 17.6 bar

Material

NO.	Component	Material
1	Body	Ductile Iron+Epoxy Coated
2	Filter	Stainless Steel (SS304)
3	O-ring	EPDM
4	Cover	Ductile Iron+Epoxy Coated
5	Washer	Stainless Steel (SS304)
6	Bolt	Stainless Steel (SS304)
7	Plug	Steel+Zinc plating

Installation Dimensions

Connection Dimension: PN16 to BS EN 1092-2

Size DN (mm)	L	H	A	B	φ C	n-φ D	Filter Screen Diameter	Free Area %	Weight(Kg)	Plug size	Kv(m³/h)
50	230	135	165	50	125	4-φ 19	φ 1.5	37.2%	8.5	RC3/8"	55
65	290	165	185	65	145	4-φ 19	φ 1.5	37.2%	12.94	RC3/8"	95
80	310	180	200	80	160	8-φ 19	φ 1.5	37.2%	15.86	RC3/8"	150
100	350	210	220	100	180	8-φ 19	φ 1.5	37.2%	23.86	RC1/2"	200
125	400	265	250	125	210	8-φ 19	φ 3.5	44.1%	33.32	RC1/2"	300
150	480	305	285	150	240	8-φ 23	φ 3.5	44.1%	43.18	RC1/2"	450
200	600	393	340	200	295	12-φ 23	φ 3.5	44.1%	78	RC3/4"	680
250	650	450	405	250	355	12-φ 28	φ 5	48.7%	129	RC3/4"	1100
300	750	532	460	300	410	12-φ 28	φ 5	48.7%	165	RC3/4"	1450
350	850	600	520	350	470	16-φ 28	φ 5	48.7%	219	RC3/4"	1750
400	950	765	580	400	525	16-φ 31	φ 5	48.7%	370	RC1-1/2"	2200
450	1050	815	640	450	585	20-φ 31	φ 5	48.7%	500	RC1-1/2"	2800
500	1150	900	715	500	650	20-φ 34	φ 5	55.6%	850	RC1-1/2"	3500
600	1350	1060	840	600	770	20-φ 37	φ 5	55.6%	950	RC1-1/2"	4850



Specification

- Test Standard: ISO/DIS 5208: 2007
- Filter Screen Diameter: Refer to the table, the flow area of filter screen is three times of the passage area
- Connection Type: Flanged, PN16 to BS EN 1092-2
- Medium: water, sewage

Approval

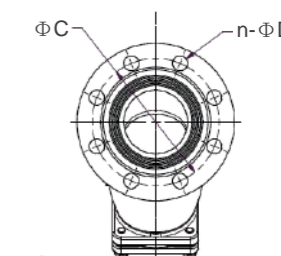
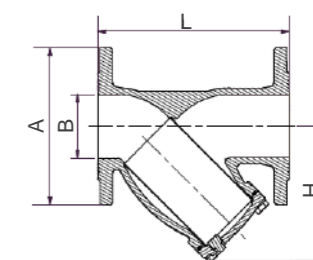
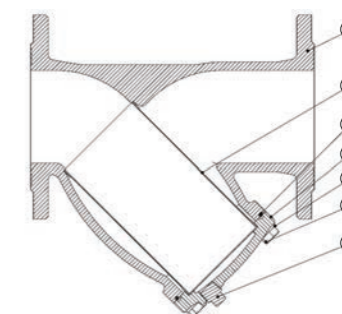



W-W4112-EN-202206

Characteristic Curve

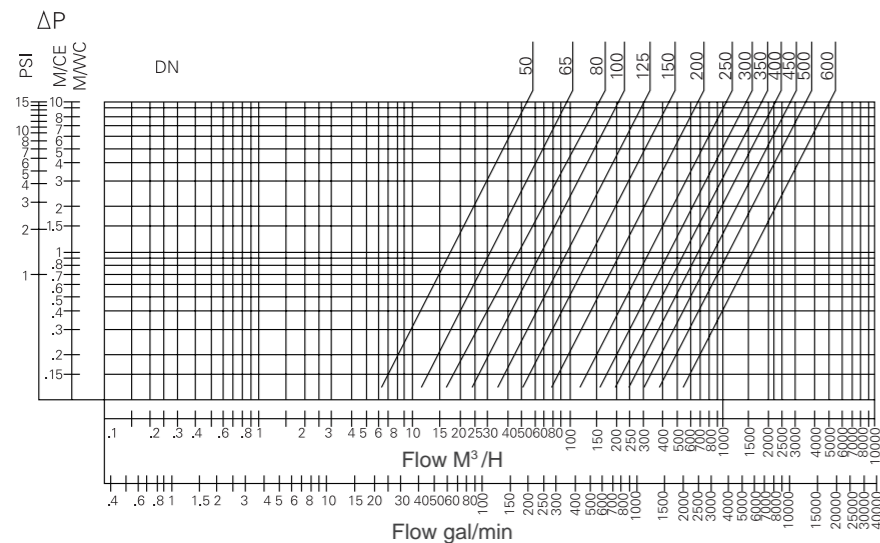

W-YG41-25C-EN-202004

Series W-YG41-25C

Y Strainer

Size: DN50-DN600

The Watts W-YG41 Y Strainer is designed to remove impurities in the medium to protect valve and equipment for normal use. It's generally used in petroleum, chemical industry, metallurgy, water treatment, etc.

Features

- Low resistance
- Simple structure and convenient installation & cleaning
- Large pollutant-holding volume and convenient pollutant discharge

Pressure-Temperature

- Nominal Pressure: PN25
- Temperature Range: -20 C - 120 C

Material

Component	Material
Body	Carbon Steel with Spray Paint
Bonnet	Carbon Steel with Spray Paint
Screen	Stainless Steel

Typical Application

- Water plant and water source project
- Environmental protection
- Municipal facilities
- Electric power and utilities
- Construction industry
- Petroleum & Chemical industry
- Steel & Metallurgy
- Papermaking industry

Installation Dimensions

DN	L	D	D1	D2	n-φd	b	f	H	Filter	Mesh
50	220	165	125	99	4-18	20	2	181	φ3	7
65	240	185	145	118	8-18	22	2	250	φ3	7
80	280	200	160	132	8-18	24	2	280	φ3	7
100	310	235	190	156	8-23	24	2	320	φ3	7
125	350	270	220	184	8-25	26	2	374	φ3	7
150	385	300	250	211	8-25	28	2	430	φ3	7
200	490	360	310	274	12-25	30	2	515	φ3	7
250	550	425	370	330	12-30	32	2	595	φ3	7
300	610	485	430	389	16-30	34	2	680	φ3	7
350	690	555	490	448	16-33	38	2	765	φ3	7
400	790	620	550	503	16-36	40	2	855	φ3	7
450	825	670	600	548	20-36	46	2	940	φ3	7
500	895	730	660	609	20-36	48	2	995	φ3	7
600	1065	845	770	720	20-39	58	2	1045	φ3	7



Specification

- Design Standard: GB/T 14382-2008
- Test Standard: GB/T 13927-2008
- Filter Screen Diameter: Ø3mm, the flow area of filter screen is two to three times of the passage area
- Working Medium: Water, sewage

Operating Principles

When the media flow through the strainer, the filter screen in the strainer will block solid impurity particles in the media in the screen and allow clean fluid to flow through the screen and discharge from the strainer outlet while the screen hole size can be adjusted based on the size of impurities.

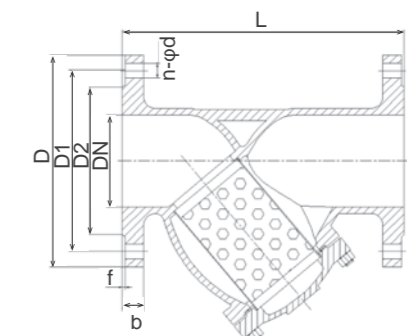



77F-DI-125-EN-202208

Series 77F-DI-125, 77F-FDA-125

Flanged, Wye Pattern, Cast Iron Strainer

Size: DN50-DN300

Series 77F-DI-125, 77F-DI-FDA-125 Flanged, Wye Pattern, Cast Iron Strainers feature 304 stainless steel perforated screens, a cast iron flanged retainer cap and a drain/blowoff connection furnished with a closure plug. Series 77F-DI FDA-125 also features a double coated, heat fused epoxy coating on the interior and exterior for FDA approved sanitary applications.

Features

- Flanges conform to American National Standards Institute, Class 125 (ANSI B16.1) and WW-S-2739 Type 2
- Lead Free* cast iron body
- 304 Stainless steel perforated screens
- Cast iron flanged retainer cap with gasket tapped for closure plug
- Drain/Blowoff connection furnished with closure plug

Pressure-Temperature

- Maximum Operating Pressure: 200psi (13.8 bar) WOG, non-shock, @ 210°F (99°C) 125psi (8.6 bar) WSP @ 353°F (178°C)

Models

77F-DI-125 — 2" – 12" (50 – 300mm) with flanged connections for water and steam service
 77F-DI-FDA-125 — 2" – 12" (50 – 300mm) with flanged connections and double coated, heat fused FDA approved epoxy coating (interior and exterior) for water service only

Material

NO.	Component	Material
A.	Screen	AISI 304SS
B.	Cover Gasket	Gasket Graphite
C.	Plug	*ASTM A47
D.	Washer	ASTM A6
E.	Cotter Pin	ASTM A112
F.	Plate	*ASTM A6
G.	Bolt Nut	ASTM A6
H.	Bolt	ASTM A6
I.	Set Screw	ASTM B16
J.	Cover Bolt Nut	ASTM A6
K.	Cover Bolt	ASTM A6
L.	Cover	*ASTM A-126 Class B
M.	Body	*ASTM A-126 Class B

Note: 77F-DI-FDA-125 component parts epoxy coated internally & externally

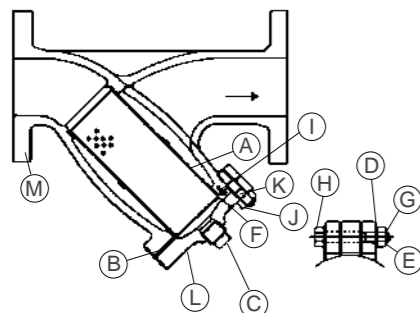

Approval



Installation Dimensions

SIZE (DN)	DIMENSIONS					WEIGHT
	A	B	C(NPT)	D*	Screen Area	
mm	mm	mm	mm	mm	sq.in.	kgs.
50	200	133	13	178	36	8
65	254	165	25	248	56	13
75	257	178	25	254	75	15
100	308	210	38	305	121	27
125	397	286	51	432	210	43
150	470	343	51	508	278	60
200	551	394	51	578	387	112
250	660	470	51	711	577	168
300	759	552	51	762	795	262

*D dimension is minimum clearance for screen removal.

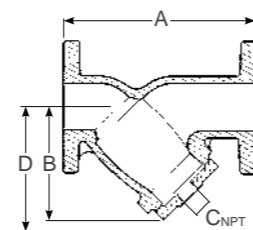

Characteristic Curve

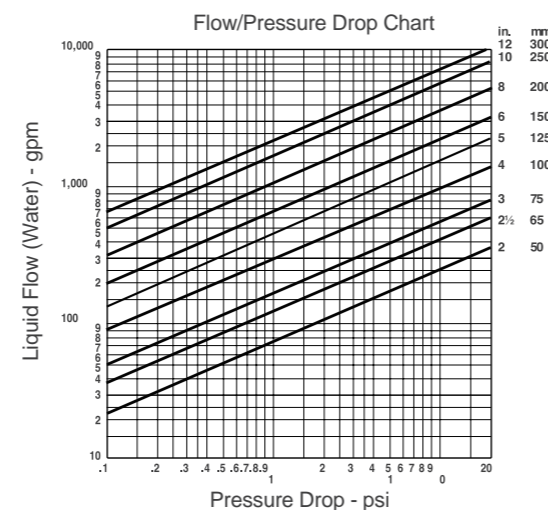

97FB-CIB-EN-202208

Series 97FB-CIB

Cast Iron, Simplex, Basket Strainer

Size: DN50-DN300

Series 97FB-CIB cast iron, simplex basket strainers are for use in liquid and steam applications. All sizes of Series 97FB-CIB are furnished with a plugged blowdown connection and angle designed baskets. Sizes 8" (200mm) and larger come with a side drain facing the outlet of the strainer. All sizes come with a bolted screen retainer cover and a graphite gasket. These strainers may only be installed in a horizontal position.

Features

- Class 125 cast iron body
- Angle-designed basket
- Flanged connections
- Stainless steel screen
- Cast iron retainer cap with graphite gasket
- Blowdown plug

Material

Component	Material
Body	ASTM A-126 Class B cast iron
Retainer Cap	ASTM A-126 Class B cast iron
Screen	304 perforated stainless steel
Cap Gasket	Graphite
Blowdown Plug	ASTM A-126 Class B cast iron

Installation Dimensions

SIZE (DN)	DIMENSIONS			REMOVAL CLEARANCE		WEIGHT
	A	B	C	D*	E (NPT)	
mm	mm	mm	mm	mm	mm	kgs.
50	206	213	127	137	25	9.9
65	210	244	135	160	25	14.0
80	251	286	165	203	25	19.0
100	292	343	203	237	25	31.7
125	333	371	203	260	25	40.8
150	378	397	219	283	32	56.2
200	479	533	298	395	20	122.4
250	508	622	349	457	20	174.1
300	667	756	416	591	25	303.9

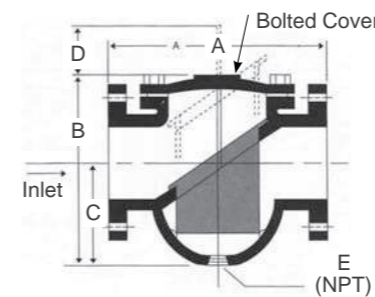

Standard Screens

SIZE	OPENINGS		STANDARD SCREENS
	in.	mm	
2-3	50-80	0.045 1.143	3/64" 304SS perf.
4-12	100-300	0.125 0.317	1/8" 304SS perf.

Watts reserves the right to change or modify product design, construction, specifications, or materials without prior notice and without incurring any obligation to make such changes and modifications on Watts products previously or subsequently sold.

Specification

The dimensions and drilling of flanges conform to ANSI B16.1, Class 125 and Class 150 flanges.

Pressure-Temperature

- Model 97FB-CIB Maximum Working Pressure: 200psi (13.8 bar) at 150°F (66°C) WOG 125psi (8.6 bar) at 353°F (178°C) WSP

Characteristic Curve

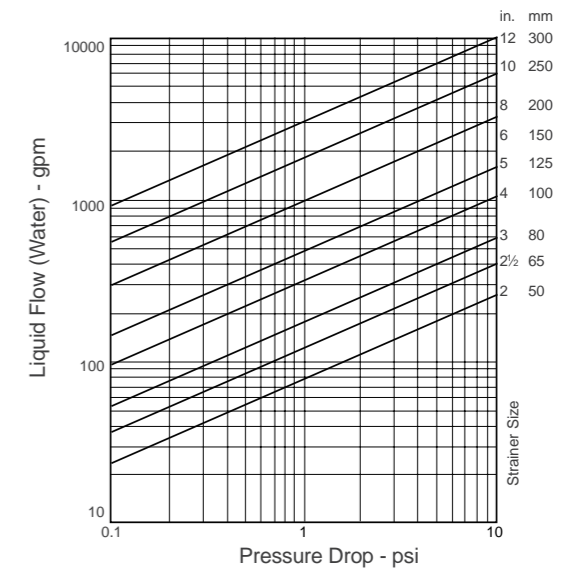



FV-4M1-EN-202208

Series FV-4M1 Automatic Air Vent Valve

Sizes: DN3 – DN25

Series FV-4M1 Automatic Air Vent Valves provide automatic air venting for hot or cold water distribution systems. These vents purge air that may be in the water system. The vent valve utilizes a float to actuate the valve plug which is located at the top of the valve. Once the air is displaced and the system pressure is sustained, the valve plug seals and prevents any water from escaping from the system. The float vent can also operate as an anti-vacuum device since it will permit air to enter the system when it must be drained. It can also be installed to permit the separation and dispersal of air while fluid is actually circulating in the system.

Features

- Body and cover are brass construction
- Air vent with silicone rubber seal
- Impurities do not usually affect function as maximum float line of water is always lower than the valve seal
- Float is high temperature resistant polyethylene
- Suitable for use with glycol systems
- Can be disassembled for inspection and cleaning

Pressure-Temperature

- Minimum working pressure: 1.45psi (10 kPa)
- Maximum working pressure: 150psi (10 bar)
- Temperature Range: 33°F – 240°F (5°C – 116°C)

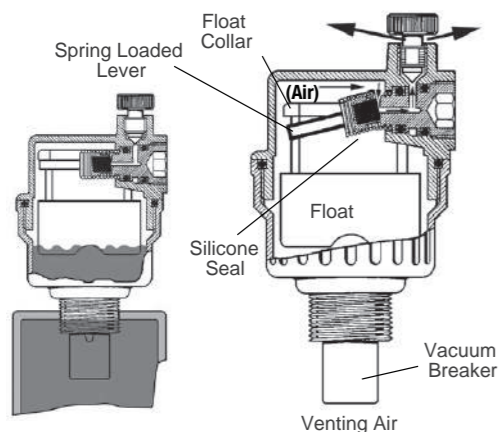

Installation Dimensions

SIZE (DN)	DIMENSIONS						WEIGHT
	A	B	C	D*	E	F	
in.	mm	mm	mm	mm	mm	mm	kg
1/8	75	67	41	21	7.9	7.9	.18
1/4	79	67	41	21	3.1	12.7	.20
1/2	85	69	32	18	16	–	.20
3/4	85	69	32	18	16	–	.20
1	89	69	35	18	20	–	.21

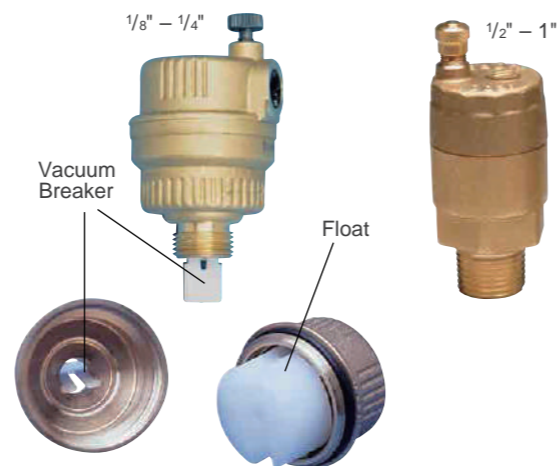

Characteristic Curve

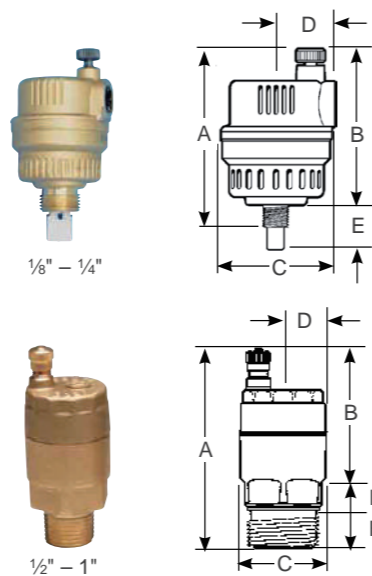
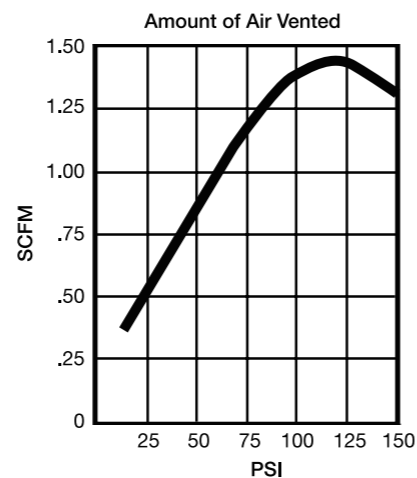

FV-4M1-EN-202208

Installation

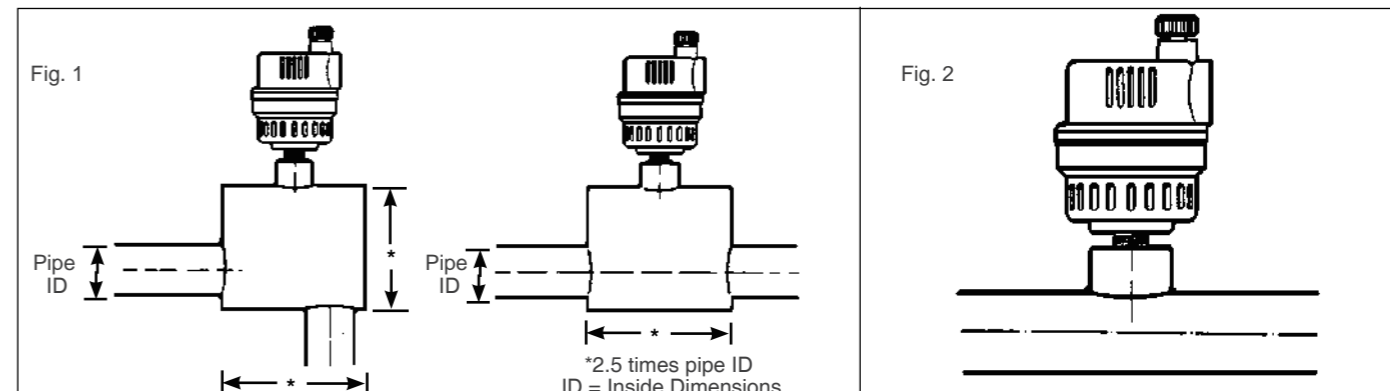

Figure 1 shows the installation of the FV-4M1 for the venting of air while the fluid is circulating in the system. The figure shows the required increase in pipe size in order to obtain proper separation of air from water. Watts Series AS Air Scoop which is designed for efficient separation of air from water in hydronic heating systems can also be installed. See Watts literature S-AS.

Figure 2 When the FV-4M1 is installed as shown, the air will not be vented while the fluid is circulating in the system, but it can vent when the system is shut off. The FV-4M1 should be mounted only in a vertical position as its operation is based on the vertical movement of the float (see Fig. 3). **Note:** In order to get the best results in venting air from risers, use connecting pipes of at least 1/2" diameter between the "Float Vent" valves and the installation.

Fig. 3

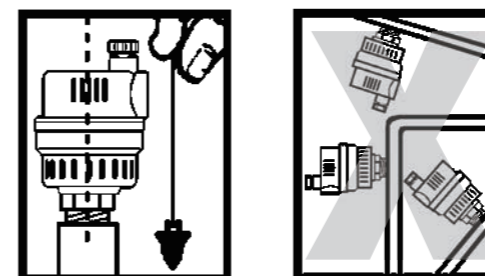
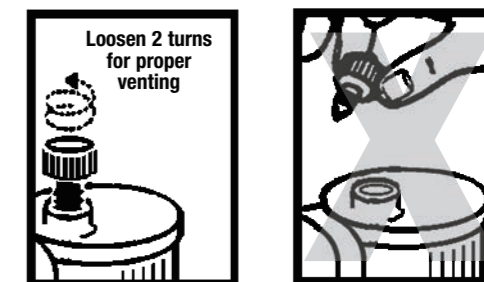

Fig. 4



Maintenance

Corrosive water conditions, and/or unauthorized adjustments or repair could render the product ineffective for the service intended. Regular checking and cleaning of the product's internal components helps assure maximum life and proper function. When the FV-4M1 is disassembled for inspection or cleaning, it is important that when re-assembling to ensure that the spring loaded lever properly engages under the float collar (see reverse side).

Operation: IMPORTANT!

After installing the FV-4M1, back off the small vent cap two turns (see Fig. 4). This is the proper operating setting which will allow air to be vented from the system. It is advisable to leave the cap on to prevent impurities from entering the valve.



MVD-EN-202212

Series MVD

Float-type Air Vent Valve

Size: DN8-DN15

Series MVD Float Vent valves are automatic and/or manual devices for venting air from heating and air conditioning systems.

Features

- Brass body and cover
- Suitable for water with additive (glycol up to 30%)
- The corrosion-resistant techno-polymer float switch
- Manual & automatic feature

Pressure-Temperature

- Nominal Pressure: PN12
- Temperature Range: 5°C-115°C

Test Pressure

- Pneumatic 6 bar

Material

NO.	Part	Material
1	Body	Brass
2	Cover	Brass
3	Disc	Polyphenylene Oxide
4	Spring	Stainless steel
5	Plug	Fiberglass-reinforced polyphenylene Oxide
6	Lever	Fiberglass-reinforced polyphenylene Oxide
7	Float	High-density expanded polythene
8	Seals	NBR
-	Vacuum Breaker	Polyacetal

Installation Dimensions

DN	CH	Weight (g)
1/4"	19	195
3/8"	19	200
1/2"	22	200

Characteristic Curves

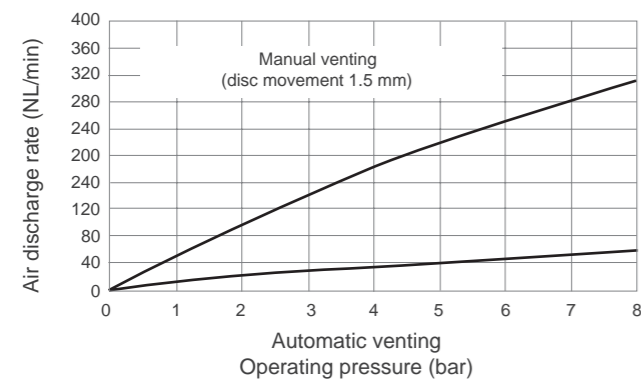

Specification

- Connection Standard: DIN-ISO 228/1
- Automatic discharge capacity at 3 bar: 17.9 NL/min
- Manual discharge capacity at 3 bar: 139.5 NL/min

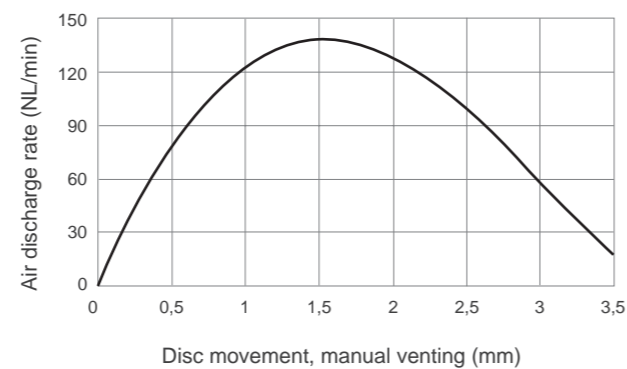
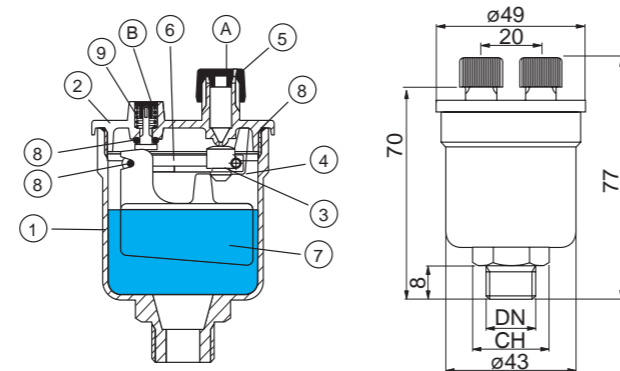

MV-EN-202212

Series MV

Float-type Air Vent Valves MiniVent

Size: DN10-DN25

Series MV Float Vent valves are automatic and/or manual devices for venting air from heating and air conditioning systems.

Features

- Brass body and cover
- Unscrewable inspection cover
- Suitable for water with additive (glycol up to 30%)
- Corrosion-resistant polythene float switch

Pressure-Temperature

- Nominal Pressure: PN12
- Temperature Range: 5°C-115°C

Test Pressure

- Pneumatic 6 bar

Material

NO.	Component	Material
1	Body	Brass
2	Cover	Brass
3	Lever	Polyacetal
4	Float	High-density expanded polythene
5	Disc	EPDM
6	Spring	Stainless steel
7	Seals	NBR
8	Cap	Polymide

Installation Dimensions

DN	CH
1/4"	19
3/8"	19
1/2"	22

Characteristic Curve

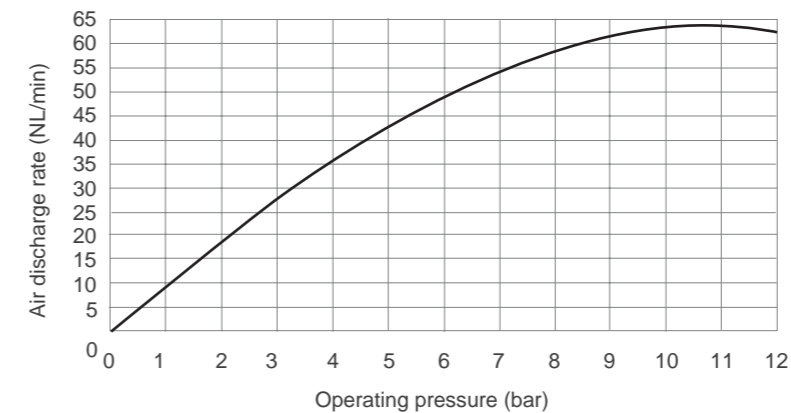

Specification

- Connection Standard: DIN-ISO 228/1

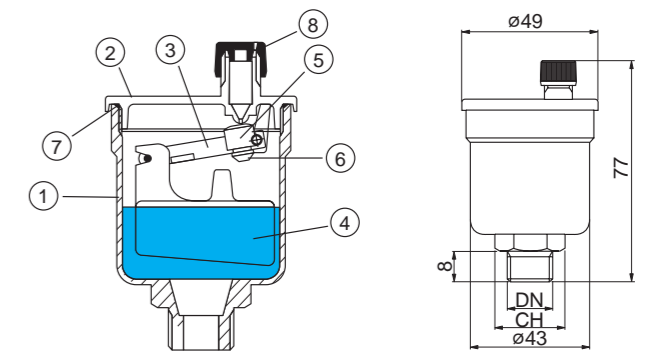



2161C-EN-202206

Series 2161C

Automatic Air Vent Valves Float Vent

Size: DN10-DN25

Series 2161C Float Vent valves are automatic and/or manual devices for venting air from heating and air conditioning systems.

Features

- Vertical automatic air vent valve
- Pre-sealed with O-ring
- Suitable for installation on the head connections of coplanar manifolds
- Brass body

Pressure-Temperature

- Nominal Pressure: PN10
- Temperature Range: 5°C~110°C

Test Pressure

Pneumatic
6bar

Material

NO.	Component	Material
1	Body	Brass
2	Control Mechanism	Stainless steel
3	Retaining Spring	Stainless steel
4	O-ring seal	EPDM
5	Disc	Silicone rubber
6	Float	Stabilized polypropylene
7	O-ring Pre-sealing	EPDM
8	Vacuum breaker	Polyacetal
9	Retaining Disc	PA with fiberglass

Installation Dimension

DN	A	B	C	D	weight(g)
3/8"	30	10	77	36	135
1/2"	30	10	77	36	150
3/4"	32	12	79	36	160
1"	37	12	79	36	170

Characteristic Curve

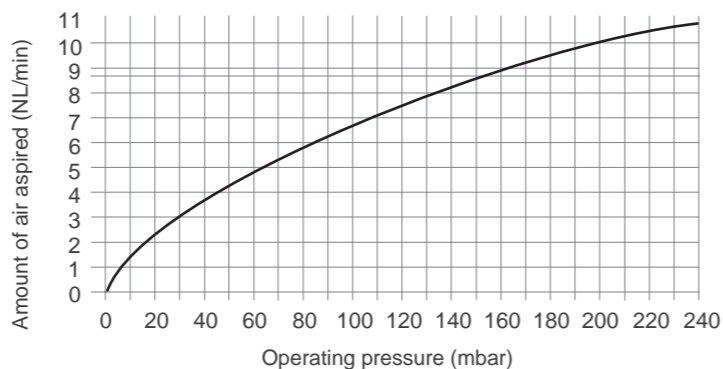
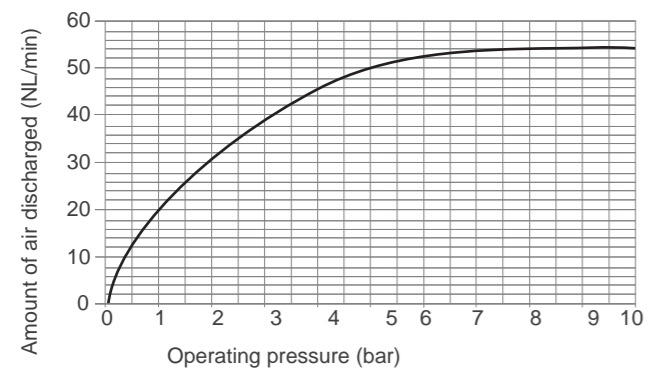

Specification

- Connection Standard: DIN-ISO 228/1

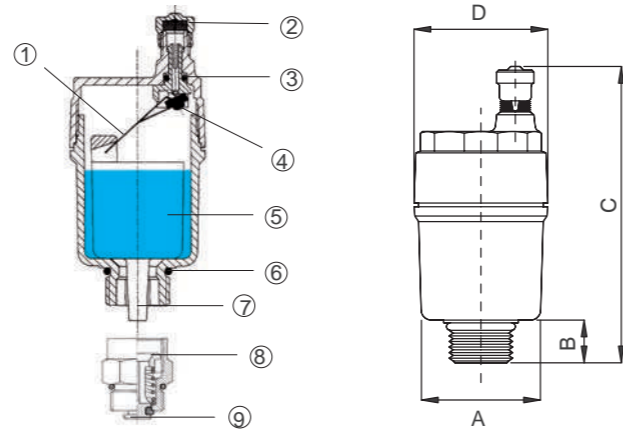

MXV-EN-202212

Series MXV

Float-type Air Vent Valves MAXIVENT

Size: DN20-DN32

Series MXV Float Vent valves are high flow automatic devices for venting air from heating and air conditioning systems.

Features

- Cast iron body and cover coated with epoxy
- Manufactured to deal with high flow rates
- Used to venting air from large water distribution pipes
- Can be equipped with manual air vent valve

Pressure-Temperature

- Nominal Pressure: PN12
- Temperature Range: 5°C~115°C

Material

Component	Material
Body	Cast Iron coated with epoxy resin
Cover	Cast Iron coated with epoxy resin
Manual Vent Valve	Chrome-plated brass
Lever	Stainless Steel
Disc	NBR
Float	High-density expanded polythene
Seals	NBR
Cap	Brass

Installation Dimensions

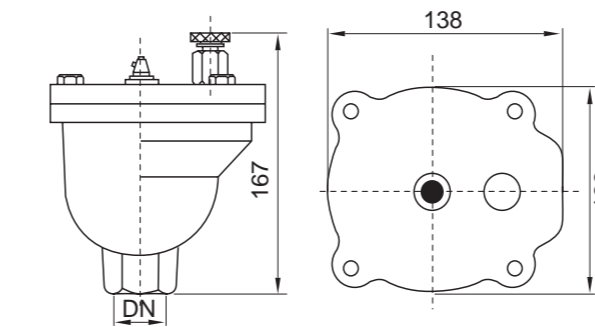

Note: Nominal diameter DN range from 20mm to 32mm



Specification

- Connection Standard: DIN-ISO 228/1
- Test Standard: EN 1074

Characteristic Curve

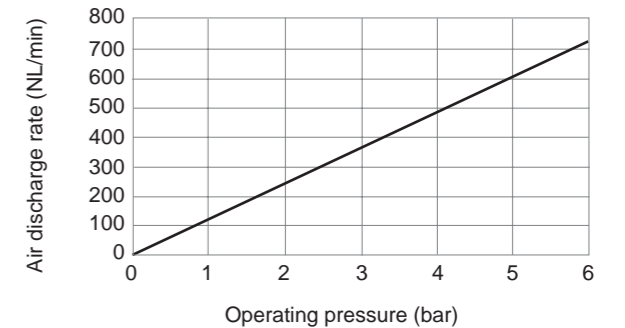



B5002/ B5002N-EN-202002

Series B5002/ B5002N

Bronze Check Valve

Size: DN15-DN50

The Watts B5002 Bronze Check Valve is designed to protect against medium backflow. The series is suitable for potable water application.

Features

- Simple Structure
- Low head loss
- Long Service Life

Pressure-Temperature

- Nominal Pressure: PN20
- Temperature Range: 0 °C ~80 °C

Test Pressures

Pneumatic	Hydraulic
Shell: 6 bar	Shell: 30 bar
Seat: 6 bar	Seat: 22 bar

Material

NO.	Component	Material
1	Drive Screw	Copper
2	Name Plate	Aluminum
3	Cap	Bronze
4	Packing	PTFE
5	Hinge Pin	Stainless Steel
6	Hinge	Bronze
7	Disc	NBR
8	Disc Holder	Bronze
9	Hinge Nut	Stainless Steel
10	Body	Bronze

Installation Dimensions

DN	Rc	d	L	H	A	Weight(kg)
DN15	1/2	12	58	36.5	10	0.22
DN20	3/4	18	66	43	11	0.37
DN25	1	24	76	49	12.7	0.54
DN32	1 1/4	30.6	88	57	14.5	0.83
DN40	1 1/2	37	96	62.5	15	1.12
DN50	2	48.6	112	72	18	1.74

*Available in both connection standard BSPT & NPT



Specification

- Design Standard: GB/T 8464/ MSS SP-80
- Connection Standard: Threaded to • ISO 7-1 BSPT, Available with NPT threading Model B5002N
- Test Standard: BS6755
- Medium: water, oil, steam

Approval

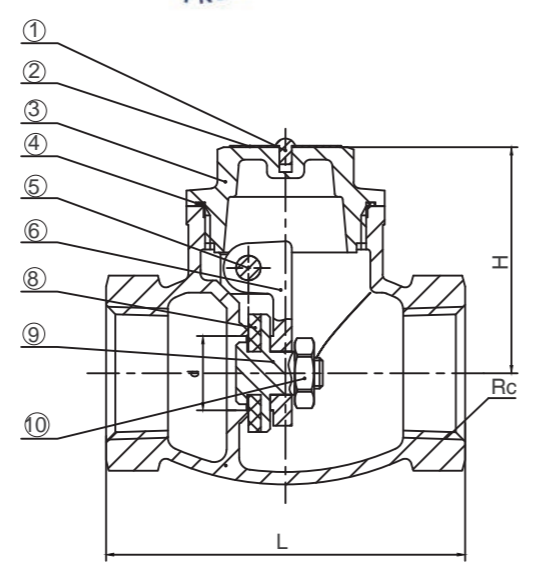

R5001/R5001N-EN-202105

Series R5001/R5001N

Brass Silent Check Valve

Size: DN15-DN50

The Watts R5001/R5001N Brass Silent Check Valve is designed to protect against medium backflow. The series is suitable for potable water application.

Features

- Operates in any position
- Low head loss
- Silent & robust
- Does not generate hammering

Pressure - Temperature

- Nominal Pressure: PN16
- Temperature Range: -20°C~110°C

Test Pressures

Pneumatic	Hydraulic
Shell: 6 bar	Shell: 24bar
Seat: 6 bar	Seat: 17.6 bar

Material

NO.	Component	Material
1	Body	Brass
2	Gasket	EPDM
3	Core	Brass
4	Spring	Stainless Steel
5	Bonnet	Brass

Installation Dimensions

Size DN(mm)	Dimensions(mm)				Wt.(kg)
	A	B	E	G*	
15	49.5	33	11	1/2"	0.118
20	47	37.5	11.5	3/4"	0.14
25	53	41.5	12	1"	0.187
32	61	54.5	13	1-1/4"	0.34
40	65	64.5	13.5	1-1/2"	0.5
50	81	78	16	2"	0.81

*Available in both connection standard BSPT & NPT



Specification

- Connection Standard: BSPT to ISO 7-1, NPT to ASME B1.20.1 / MSS SP-80
- Test Standard: BS EN 12266-1
- Medium: water

Approval

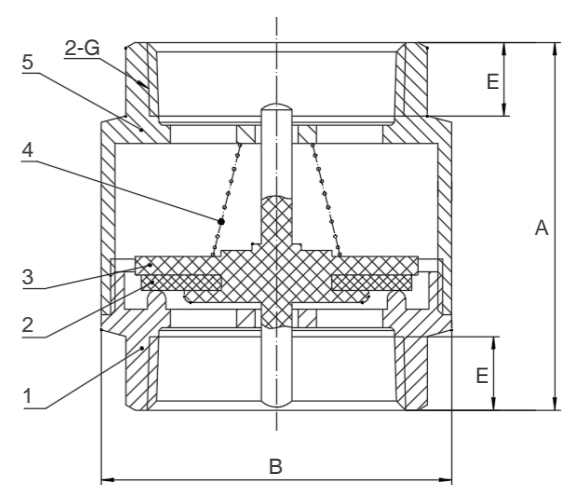



R5002/R5002N-EN-202105

Series R5002/R5002N

Brass Swing Check Valve

Size: DN15-DN50

The Watts R5002/R5002N Brass Swing Check Valve is designed to protect against medium backflow. The series is suitable for potable water application.

Features

- Simple Structure
- Low head loss
- Long Service Life

Pressure - Temperature

- Nominal Pressure: PN16
- Temperature Range: -20°C~110°C

Test Pressures

Pneumatic	Hydraulic
Shell: 6 bar	Shell: 24bar
Seat: 6 bar	Seat: 17.6 bar

Material

NO.	Component	Material
1	Body	Brass
2	Rocker Panel	Brass
3	Rotating Shaft	Brass
4	Gasket	PTFE
5	Bonnet	Brass

Installation Dimensions

Size DN(mm)	Dimensions(mm)					Wt.(kg)
	A	B	L	H	G*	
15	13	11	46	35	1/2"	0.15
20	18	11.5	57	36.5	3/4"	0.23
25	22	12	65	47	1"	0.34
32	28	13	70	49	1-1/4"	0.52
40	33	13.5	76	55.5	1-1/2"	0.72
50	41	16	95	64	2"	1.12

* Available in both connections standard BSPT & NPT



Specification

- Connection Standard: BSPT to ISO 7-1, NPT to ASME B1.20.1 / MSS SP-80
- Test Standard: BS EN 12266-1
- Medium: water

Approval

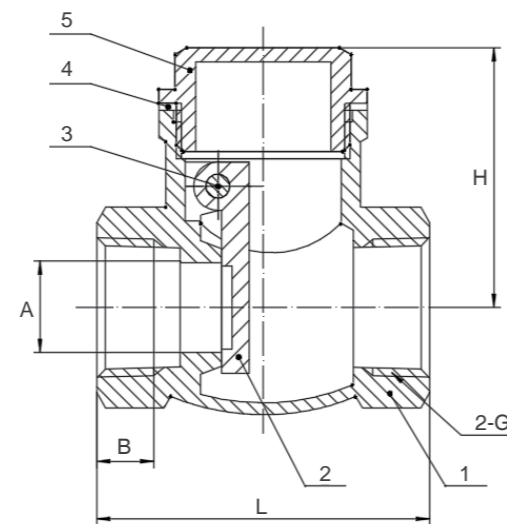

W-H77X-16Q-EN-202206

Series W-H77X-16Q

Wafer Double Door Check Valve

Size : DN50-DN600

The Watts W-H77X Wafer Style Check Valve is designed to automatically open the valve by the flow of the medium itself, and close the disc relying on the spring torsion and medium flow, which is used to prevent the backflow of the medium. It's generally used in building services, water treatment, plate heat exchanger, etc.

Features

- Light weight and compact structure
- Rely on the torsion spring to quickly close on its own
- Can be installed in both horizontal and vertical pipes
- Safe and reliable performance, good anti-interference performance

Pressure - Temperature

- Nominal Pressure: PN16
- Temperature Range: -10°C ~ 120°C

Test Pressures

Hydraulic
Shell: 24bar
Seat: 17.6bar

Material

NO.	Component	Material
1	Body	Ductile Iron
2	Seat	EPDM
3	Disc	Stainless Steel (SS304)
4	Spring	Stainless Steel (SS304)
5	Valve Shaft	Stainless Steel (SS410)

Installation Dimension

Connection Dimension: EN558-1 series 16

Dimension (mm)	DN (mm)													
	50	65	80	100	125	150	200	250	300	350	400	450	500	600
A	107	127	142	162	192	218	273	328	378	438	489	539	594	695
B	65	80	94	117	145	170	224	265	310	360	410	450	505	624
H	43	46	64	64	70	76	89	114	114	127	140	152	152	178

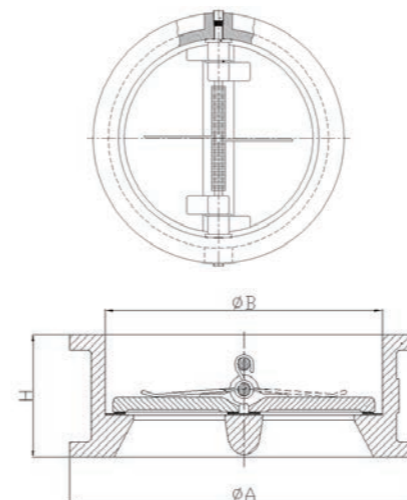

Specification

- Connection Standard: EN1092-2
- Connection Type: Wafer
- Medium: water

Characteristic Curve

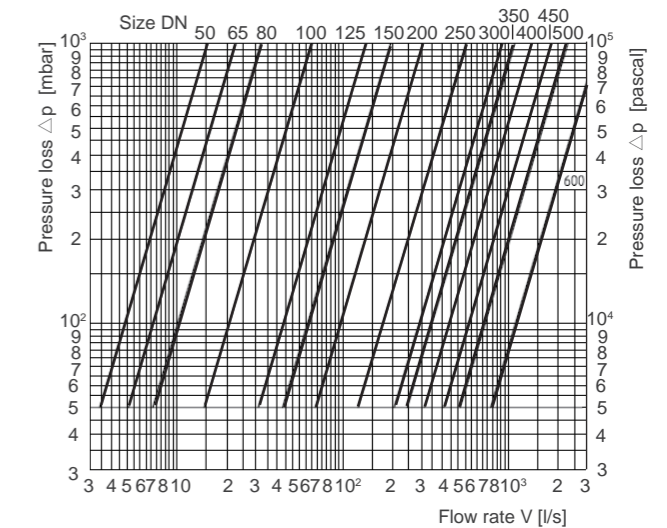

Series 815

Non-Return Valves - System 05

Size: DN50-DN600

Features

- Operating position: horizontal and vertical
- Minimum occupation of space
- Very low head loss
- Closing system: double plate with return spring
- Using these check valves on networks equipped with piston pumps or compressors are not recommended.

Pressure-Temperature

- Nominal Pressure: PN25
- Temperature Range: -10°C~100°C

Typical Application

- Pumping Applications
- Water Distribution and Supply
- General Industry Applications

Material

NO.	Component	Material
1	Casing*	Ductile iron/Epoxy
2	Plstes	Stainless steel(SS316)
	DN 50-300&400	Aluminum bronze
	DN 350&450-600	
3	Seal	EPDM
	DN50-300&400	NBR
	DN 350&450-600	
4	Spring	Stainless steel(SS316)
5	Stem	Stainless steel(SS316)
6	Bearings	PTFE
7	Eye Bolt DN>150	Steel XC15
8	Plugs	Brass

*DN 350 & DN450 to DN 600: external epoxy coating only

Installation Dimensions

DN	B	C	D	Weight	Opening pressure	Kv	ζ
mm	mm	mm	mm	(kg)	in mm/WC↑	m ³ /H	
50	54	60	109	2.5	Near 0	3,500	6.30
65	54	73	129	3.2		6,460	4.10
80	57	89	144	3.4		13,000	3.40
100	64	114	170	5.6		18,700	2.50
125	70	141	194	8.1		29,100	1.45
150	76	168	220	10.4		55,200	1.00
200	95	219	286	18.5		106,500	1.10
250	108	273	340	29.5		205,500	1.10
300	143	324	403	44.1		325,300	1.10
350	184	356	460	78		425,400	1.30
400	191	410	517	101		500,000	1.60
450	203	457	567	146.9		654,700	1.50
500	213	508	627	189.7		780,000	1.60
600	222	610	734	290		1126,900	1.60

Specification

- Design Standard: CE conformity directive 2014/68/UE
- Connection Standard: Flanged to EN1092-2
- Test Standard: EN12266-1 (P10- P12)
- ACS Approved: DN50-300 & DN400
- Medium: clear water, gas

Approvals



PED 97/23/CE

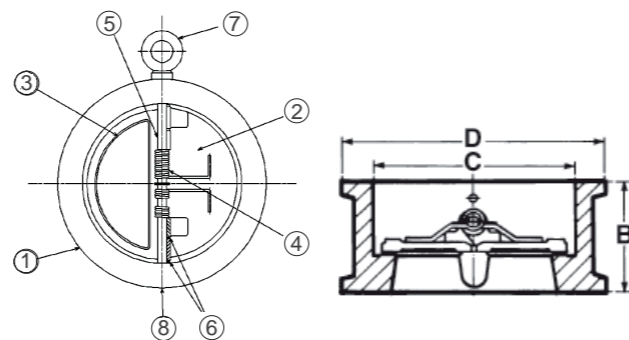

Characteristic Curve

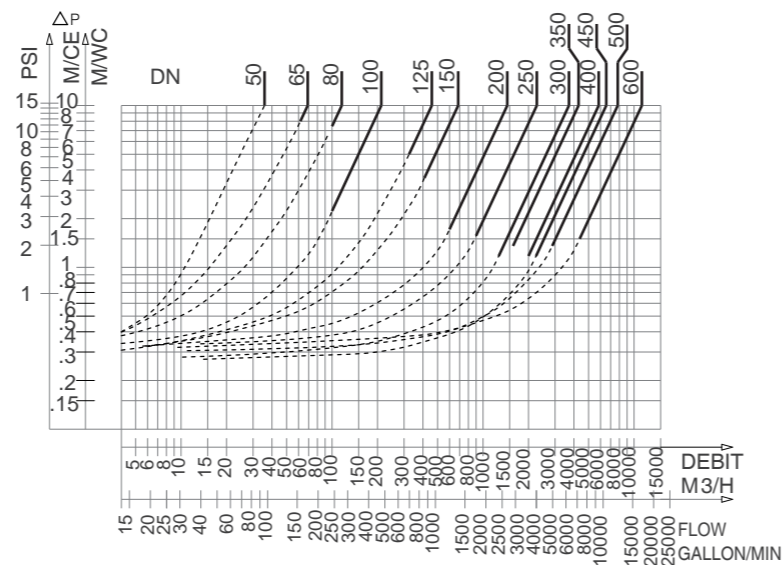

Series 402

Silent Check Valve

Size: Flange DN50-DN300

The Watts 402 Silent Check Valve is designed to protect against medium backflow. The valve is suitable for water supply and drainage systems, high-rise building pipe network, and widely used in the pipeline of pump discharge, HVAC, irrigation, commercial, industrial application.

Features

- Horizontal or vertical installation
- Low head loss
- Silent, soft-sealing, compact
- Exceptional robustness
- Does not generate hammering
- A closing system, long back axial guiding for reduced displacement
- Flange notch provided for cable to submerged pumps until DN 100

Pressure - Temperature

- Nominal Pressure: PN16
- Temperature Range: -10°C ~ 100°C

Test Pressures

Pneumatic	Hydraulic
Seat: 7 bar	Shell: 24 bar
	Seat: 17.6 bar

Material

NO.	Component	Material
1	Body	Cast Iron+Epoxy Coated
2	O-Ring	EPDM
3	Guide	Grey Iron+Epoxy Coated
4	Bushing	Stainless Steel(SS304)
5	Spring	Stainless Steel(SS304)
6	Stem	Stainless Steel(SS420)
7	Seat	Grey Iron+Epoxy Coated
8	Disc	EPDM

Characteristic Curve

Size DN	50	65	80	100	125	150	200	250	300
Kv(m ³ /h)	99	159	222	396	619	890	1120	2010	2459

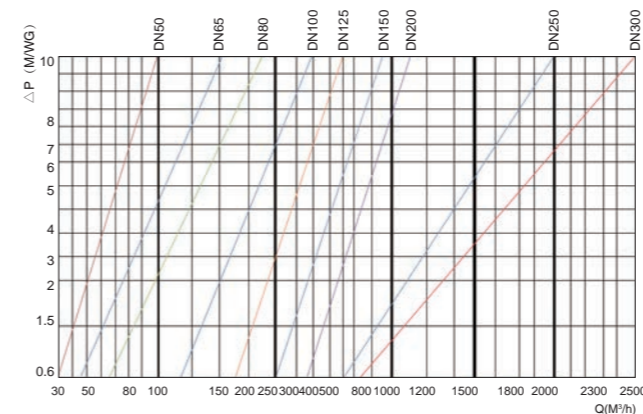

Specification

- Connection Standard: Flanged is available, PN16 to BS EN 1092-2
- Test Standard: ISO/DIS 5208:2007
- Medium: water

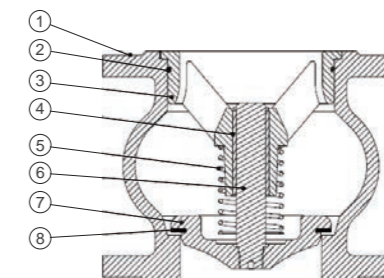

Installation Dimensions

Connection Dimension: PN16 to BS EN 1092-2

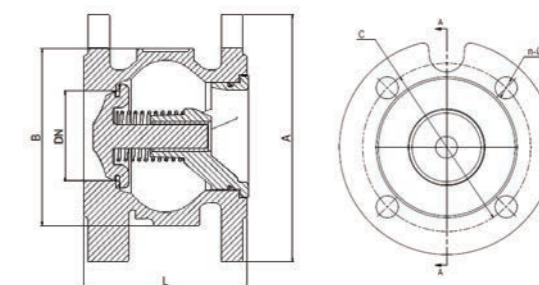

Size DN	L	A	B	C	n-φD	Kv(m ³ /h)
50	100	165	103	125	4-φ 19	99
65	120	185	131	145	4-φ 19	159
80	140	220	156	160	8-φ 19	222
100	170	220	194	80	8-φ 19	396
125	200	250	229	210	8-φ 19	619
150	230	285	268	240	8-φ 23	890
200	289	340	344	295	12-φ 23	1120
250	354	405	422	355	12-φ 28	2010
300	396	460	492	410	12-φ 28	2459



W-H44T-16Q/Z-EN-202212

Series W-H44T-16Q

Swing Check Valve

Size: DN50-DN300

The series W-H44T Swing Check Valve is designed to protect against medium backflow. It's generally used in plumbing, HVAC, irrigation, commercial, and industrial application.

Features

- Simple structure
- Low head loss
- Long service life

Pressure-Temperature

- Nominal Pressure: PN16
- Temperature Range: -15°C~120°C

Test Pressures

Hydraulic	
Shell:	24bar
Seat:	17.6bar

Material

NO.	Component	Material
1	Bolt	Stainless Steel
2	Valve Bonnet	Ductile Iron(16Q)
3	Gasket	Graphite
4	Hinge Pin	Stainless Steel
5	Plug	Stainless Steel
6	Arm	Ductile Iron
7	Bolt Assembly	Stainless Steel
8	Valve Disc	Ductile Iron(16Q)
9	Seat&Discring	Bronze
10	Valve Body	Ductile Iron(16Q)

Installation Dimensions

Dimension (mm)	DN (mm)								
	50	65	80	100	125	150	200	250	300
L	203	216	241	292	330	356	495	622	698
H	113	133	142	163	197	212	257	299	331

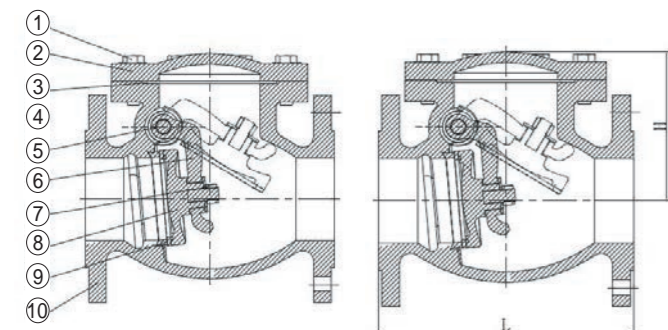

Specification

- Design Standard: BS5153
- Connection Standard: PN16 to EN 1092-2
- Connection: Flange
- Corrosion Protection: internally and externally liquid epoxy painted
- Medium: water

Characteristic Curve

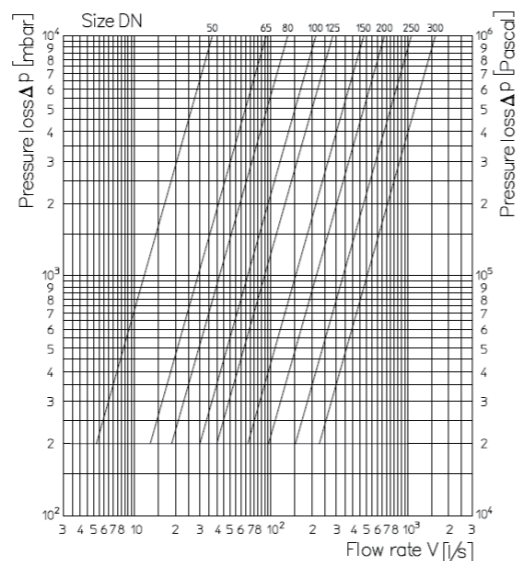

W-H44T-125Q-EN-202212

Series W-H44T-125Q

Swing Check Valve

Size: DN50-DN300

The series W-H44T Swing Check Valve is designed to protect against medium backflow. It's generally used in plumbing, HVAC, irrigation, commercial, and industrial application.

Features

- Simple structure
- Low head loss
- Long service life

Pressure-Temperature

- Nominal Pressure: CL125
- Temperature Range: -15°C~120°C

Test Pressures

Hydraulic	
Shell:	24bar
Seat:	17.6bar

Material

NO.	Component	Material
1	Bolt	Stainless Steel
2	Valve Bonnet	Cast Iron
3	Gasket	Graphite
4	Hinge Pin	Stainless Steel
5	Plug	Stainless Steel
6	Arm	Ductile Iron
7	Bolt Assembly	Stainless Steel
8	Valve Disc	Cast Iron
9	Seat& Disc ring	Bronze
10	Valve Body	Ductile Iron

Installation Dimensions

Dimension (mm)	DN (mm)								
	50	65	80	100	125	150	200	250	300
L	203	216	241	292	330	356	495	622	698
H	118	132	140	162	175	210	240	287	319

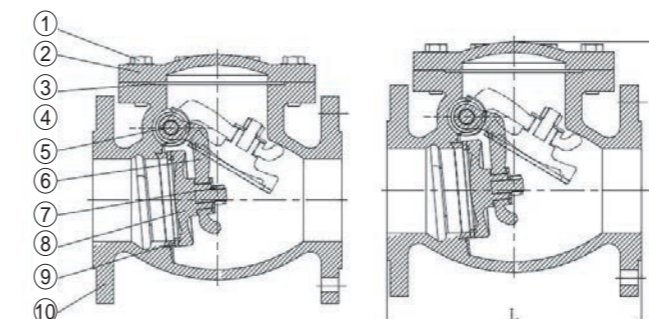

Specification

- Design Standard: MSS SP-71
- Connection Standard: CL125 to ANSI B16.1
- Connection: Flange
- Corrosion Protection: internally and externally liquid epoxy painted; Color: WATTS blue
- Medium: water, oil, gas

Characteristic Curve

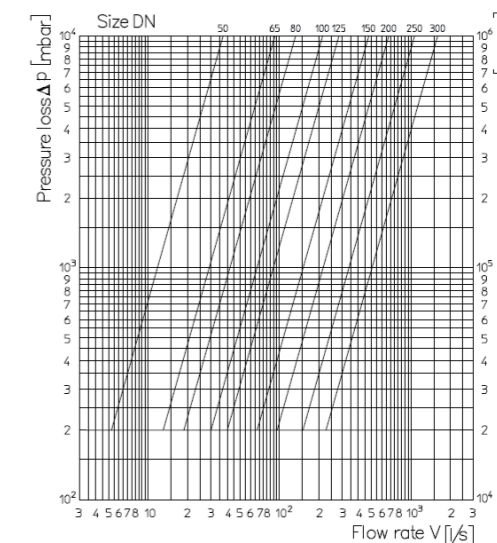



R5003/ R5003N-EN-202209

Series R5003/R5003N

Brass Non-return Foot Valve

Size: DN15-DN50

The Watts R5003/R5003N non-return foot valve is designed for clear water pumping systems with substantial flow, requiring large valves for supply systems. It guarantees excellent hydraulic performance.

Features

- Operates in any position
- Low head loss
- Silent & robust
- Does not generate hammering

Pressure-Temperature

- Nominal Pressure: PN16
- Temperature Range: 0°C~80°C

Test Pressures

Pneumatic	Hydraulic
Shell: 6 bar	Shell: 24 bar
Seat: 6 bar	Seat: 17.6 bar

Material

NO.	Component	Material
1	Bonnet	Brass
2	Gasket	EPDM
3	Disc Assembly	Brass
4	Spring	Stainless Steel
5	Body	Brass
6	Filter	Stainless steel w/ ABS

Installation Dimensions

DN	A	B	C(min)	SW(min)	E(min)	L±2	Weight(kg) ± 5%
DN15	49.5	33	1.4	24	11	84.5	0.136
DN20	47	37.5	1.4	30	11.5	85	0.164
DN25	53	41.5	1.5	37	12	100	0.228
DN32	61	54.5	1.8	46	13	111	0.404
DN40	65	64.5	1.8	52.5	13.5	126	0.597
DN50	81	78	1.8	66	16	151	0.921

*All dimensions are in mm.



Specification

- Connection Standard: BSPT to ISO 7-1, NPT to ASME 1.20.1
- Test Standard: BS EN 12266-1
- Medium: water

Approval

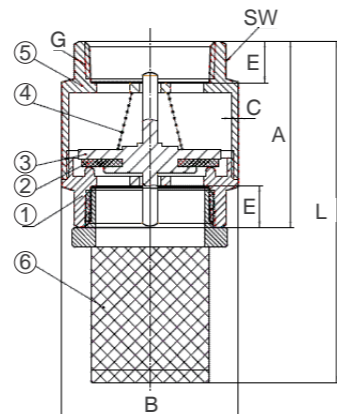

60S-EN-202208

Series 60S

Non-return Foot Valve

Size: DN20-DN100

This non-return foot valve is designed for clear water pumping systems with substantial flow, requiring large valves for supply systems. It guarantees excellent hydraulic performance.

Features

- Operates in any position
- Reliable, robust, simple
- Minimum head loss
- Closing system : four legs reinforced guide, release spring anti-rotation
- Perfect sealing at high as at low pressure ensured by a flat seal
- Long axial guiding

Pressure - Temperature

- Operating temperature: -10 °C to 80 °C
- Permissible operating pressure (PFA) in water: 16bar

Material

NO.	Component	Material
1	Body	Unleaded bronze
2	Screw	Stainless steel
3	Flat washer	DN 3/4" DN 1"1/2 Others DN
		Hostaform Delrin Stainless steel
4	Seal	NBR
5	Screw	Stainless steel
6	Nut	Stainless steel
7	Spring	Stainless steel
8	Guide	DN 2"1/2 and 3" DN 4" Others DN
		Unleaded bronze Stainless steel Delrin
9	Strainer	Stainless steel
10	Cap	DN 2"1/2, 3" and 4" DN 1"1/4 and 1" Others DN
		Unleaded bronze Polycarbonate Delrin

Characteristic Curve

- Solid line: Valve completely open
- Dotted line: opening stage of valve

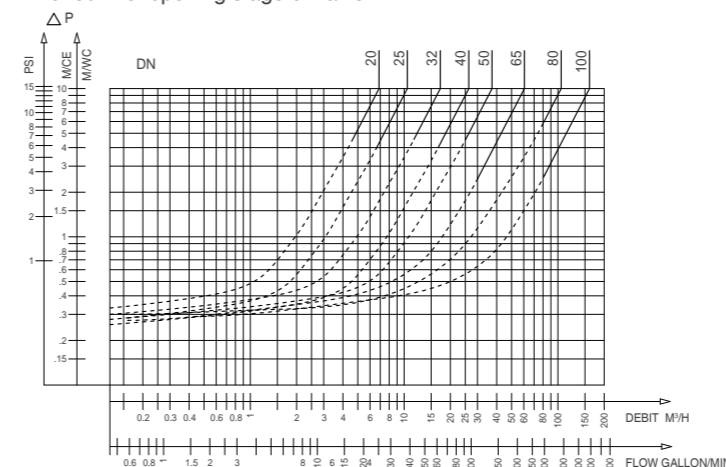

60S - Headloss chart

Watts reserves the right to change or modify product design, construction, specifications, or materials without prior notice and without incurring any obligation to make such changes and modifications on Watts products previously or subsequently sold.



Specification

- Connection: Female, BSP
- Mediums: Clear liquids, hydrocarbons

Approval



Directive 2014/68/UE
Thread connection NFE 03-005 ISO228

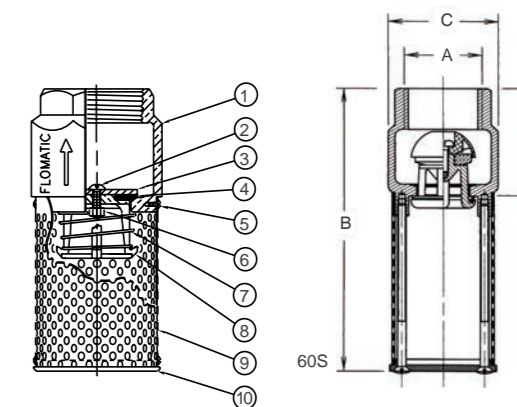

Installation Dimensions

"	A	B	C	D
	mm	mm	mm	mm
3/4	20/27	90	33	37
1	26/34	125	49	45
1 1/4	33/42	127	57	47
1 1/2	40/49	138	65	58
2	50/60	146	77	66
2 1/2	66/76	205	93	74
3	80/90	243	116	97
4	102/114	315	156	108

Watts reserves the right to change or modify product design, construction, specifications, or materials without prior notice and without incurring any obligation to make such changes and modifications on Watts products previously or subsequently sold.



302-EN-202212

Series 302

Foot Valve - System 02

Size: DN50- DN500

Features

- Operates in any position from horizontal to vertical ascending
- Minimum head loss
- Silent, reliable sealing, compact, does not generate hammering
- Exceptional robustness
- Closing system: long back axial guiding for reduced displacement
- Sealing guaranteed by a flat seal Return spring
- Return spring

Pressure - Temperature

- Nominal Pressure: PN10
- Temperature Range: -10°C ~ 80°C

Approvals



Material

NO.	Component	Material
1	Casing	Cast iron/Epoxy
2	Ring	Bronze
3	Guide DN50 Other DN	Bronze Cast iron/Epoxy
4	Spring	Stainless steel
5	Seal	EPDM
6	Closing System DN50-65 : One-piece	Cast iron/Epoxy Bronze
7	Stem	Bronze
8	Screw DN50 to 150 Screw DN200 to 400	Galvanized steel Brass
9	Strainer Strainer (Optional)	Galvanized steel Stainless steel 304L

Installation Dimensions

DN(A)	B	C	D	Weight	Opening pressure in mm/CE		Kv	ζ
mm	mm	mm	mm	(kg)	↑	Without spring	m ³ /H	
50	143	165	97	4,3	230	110	57,70	3
65	185	185	125	6,4	240	130	89	3,60
80	218	200	150	9,3	280	130	138,70	3,40
100	265	220	181	13,6	290	130	223,40	3,20
125	333	254	217	19	350	150	380	2,70
150	373	285	256	28	400	170	542,25	2,75
200	483	343	336	48	450	190	923	3
250	572	406	416	90	560	250	1354,65	3,40
300	652	482	486	133	760	365	1821,40	3,90
350	771	533	580	226	810	380	2580,30	3,60
400	876	597	676	343	900	450	3324,35	3,70
500	1094	670	880	560			5092	3,85



Specification

- Design Standard: CE Conformity Directive 97/23/CE
- Connection Standard: flanged to EN 1092-2
- Test Standard: EN12266-1 (P10- P12)
- Medium: clear liquids
- Available at PN16 for DN50 to DN150

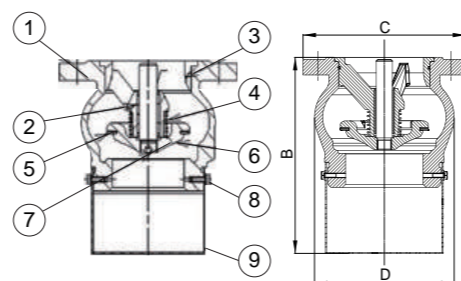

Characteristic Curve

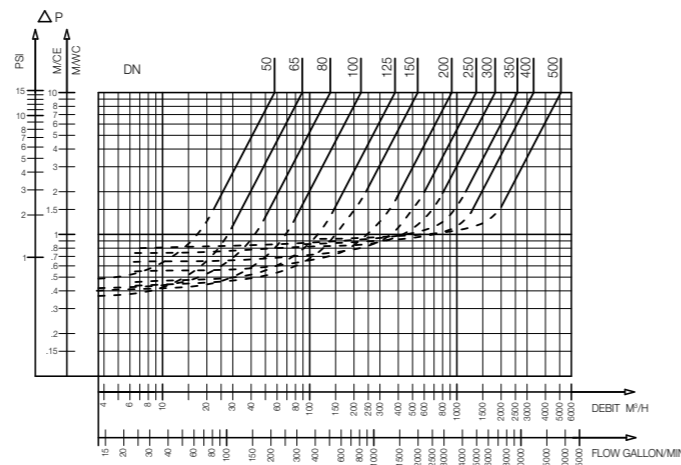

302P-EN-202212

Series 302P

Foot Valve - System 02

Size: DN50- DN100

Features

- Operates in any position from horizontal to vertical ascending
- Minimum head loss
- Silent, reliable sealing, compact, does not generate hammering
- Exceptional robustness
- Closing system: long back axial guiding for reduced displacement
- Sealing guaranteed by a flat seal
- Return spring

Pressure - Temperature

- Nominal Pressure: PN16
- Temperature Range: -10°C ~ 100°C

Typical Application

- Pumping, Irrigation, Industry & Agriculture

Material

NO.	Component	Material
1	Casing	Cast iron + epoxy
2	Ring	Bronze
3	Guide DN50 Dn65 To 100	Bronze Cast iron + epoxy
4	Spring	Stainless steel
5	Seal	EPDM
6	Closing System DN80-100 Dn50-65: One-piece	Cast iron + epoxy Bronze
7	Stem	Bronze
8	Screw	Stainless steel
9	Strainer	PP (Polypropylene)

Installation Dimensions

"	DN		B	C	D	Weight	Opening pressure in mm/CE		Kv	ζ
	mm	mm					mm	mm		
2	50	171	165	97	4,2	230	110	89,00	1,23	
2 1/2	65	212	185	125	6,2	240	130	143,00	1,36	
3	80	257	200	150	9	280	130	199,00	1,60	
4	100	313	220	181	13,2	290	130	356,00	1,20	

Characteristic Curve

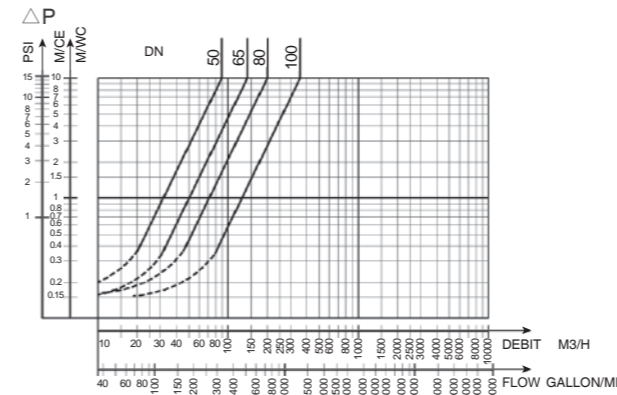

- Directions for use:
- Solid line: Valve completely open
 - Dotted line: opening stage of valve



Specification

- Design Standard: CE Conformity Directive 97/23/CE
- Connection Standard: flanged to EN1092-2
- Medium: clear liquids

Approvals

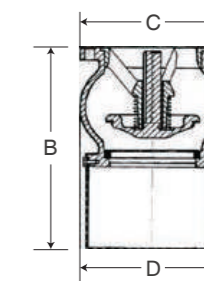
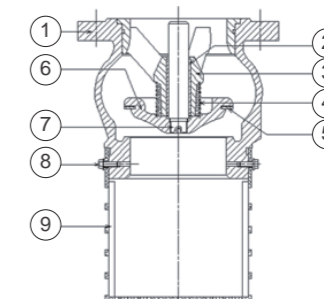



302Z-EN-202212

Series 302Z

Foot Valve - 02 System

Size: DN50-DN100

Features

- Operates in any position from horizontal to vertical ascending
- Minimum head loss
- Silent, reliable sealing, compact, does not generate hammering
- Exceptional robustness
- Closing system: long back axial guiding for reduced displacement
- Sealing guaranteed by a flat seal
- Return spring

Pressure-Temperature

- Nominal Pressure: see Table A
- Temperature Range: -10°C~80°C

Material

NO.	Component	Material
1	Body	Bronze
2	Guide	Bronze
3	Spring	Stainless Steel
4	Seal	EPDM
5	Closing System	Bronze
6	Screw	Stainless Steel
7	Strainer	PP (Polypropylene)

Installation Dimensions

DN	B	C	D	Poids (kg)
2	50	171	165	5.1
2 ^{1/2}	65	212	185	7.5
3	80	257	200	10.8
4	100	312.5	220	15.9

Characteristic Curve

DN	Opening pressure in mm/CE	Kv	∅
2	230	57.70	3
2 ^{1/2}	240	89	3.60
3	280	138.70	3.40
4	290	223.40	3.20

Directions for use:

- Solid line: Valve completely open
- Dotted line opening stage of valve

Technical Description

DN	PN	PFA bar	PS(bar)				Cat	References
			L1	L2	G1	G2		
2	10/25	25	25	25	x	x	4.3	149B2776
2 ^{1/2}	10/16	16	16	16	x	x	4.3	149B2777
3	10/16	16	16	16	x	x	4.3	149B2778
4	10/16	16	16	16	x	x	4.3	149B2779

Important notice:

The indicated pressure for the different categories of fluids (L1/L2/G1/G2) is under no condition a guarantee of use. Therefore, it is essential to validate the use of products under given operating conditions



Specification

- Design Standard: CE Conformity Directive 97/23/CE
- Connection Standard: flanged to EN1092
- Test Standard: EN12266-1 (P10- P12)
- Mediums: clear liquids, seawater

Approvals

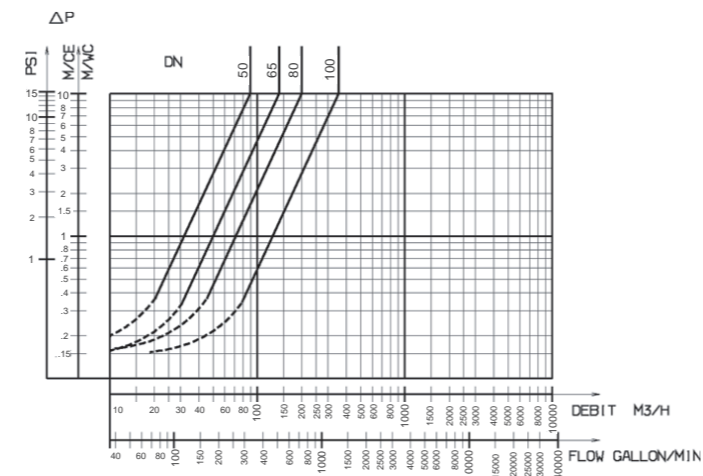
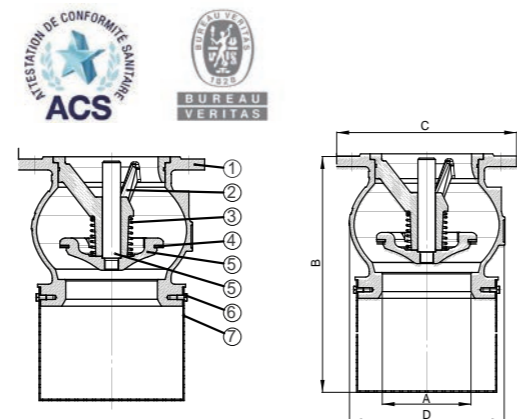

W-WB251-25T-EN-202212

Series W-WB251-25T

Brass Globe Valve

Size: DN15-DN50

The series W-WB251 Globe Valve is designed to regulate the flow in pipeline. It's generally used in building services, water treatment, etc.

Features

- Simple structure
- Metal seat
- Rising stem

Pressure - Temperature

- Nominal Pressure: PN25
- Temperature Range: 0°C~ +120°C

Test Pressures

Pneumatic
Shell: 6 bar
Seat: 6 bar

Material

NO.	Component	Material
1	Body	Brass
2	Disc	Brass
3	Stem	Brass
4	Gasket	PTFE
5	Bonnet	Brass
6	Stem Packing	PTFE
7	Gland	Brass
8	Packing Nut	Brass
9	Name Plate	Aluminum
10	Wheel Nut	Carbon Steel
11	Handwheel	Cast Iron

Installation Dimension

Connection Dimensions: ASME B1.20.1

Dimension (mm)	DN (mm)					
	15	20	25	32	40	50
D	50	54	62	69	75	84
H	70	79	88	108	115	132
L	47.5	54	67	76.5	86	102
Weight(Kg)	0.30	0.42	0.65	1.04	1.60	2.24

Thread Identifier

Connection Dimensions: ASME B1.20.1

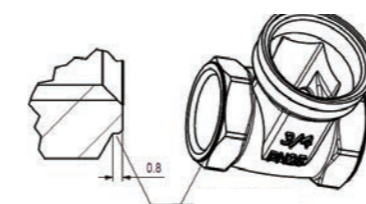

validate the use of products under given operating conditions



Specification

- Connection: Threaded
- Connection Standard: NPT to ASME B1.20.1 BSPT to ISO 7-1
- Test Standard: ISO 5208/ MSS SP-80
- Medium: water, oil, gas

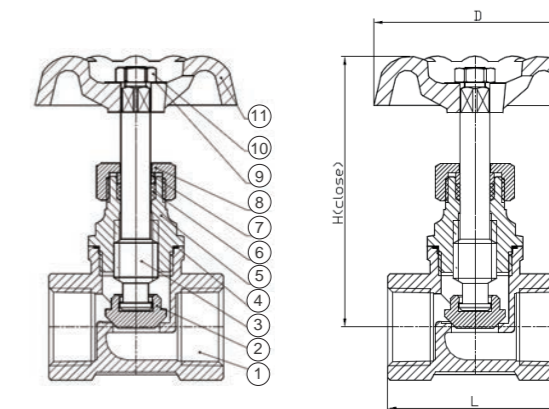

Connection Dimensions: ISO 7-1

Dimension (mm)	DN (mm)					
	15	20	25	32	40	50
D	50	54	62	69	75	84
H	70	79	88	108	115	132
L	47.5	54	67	76.5	86	102
Weight(Kg)	0.30	0.42	0.65	1.04	1.60	2.24

Connection Dimensions: ISO 7-1

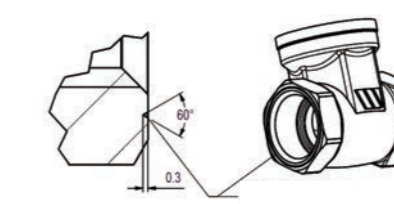



W-J41T-16Z-EN-202212

Series W-J41T-16Z

Globe Valve

Size: DN50-DN300

The series W-J41T Globe Valve is designed to regulate the flow in a pipeline. It's generally used in plumbing, HVAC, irrigation, commercial, and industrial application.

Features

- Simple structure
- Metal seat
- Packing replaceable under pressure

Pressure - Temperature

- Working Pressure: PN16
- Temperature Range: -15°C ~ 120°C

Test Pressures

Hydraulic	
Shell:	24 bar
Seat:	17.6 bar

Material

NO.	Component	Material
1	Valve Body	Cast Iron
2	Seat & Disc ring	Bronze
3	Disc	Cast Iron
4	Stem	Brass
5	Gasket	Graphite
6	Valve Bonnet	Cast Iron
7	Packing	Graphite
8	Packing Gland	Ductile Iron
9	Stem Nut	Carbon Steel
10	Handwheel	Cast Iron
11	Nut	Carbon Steel
12	Bolts	Carbon Steel

Installation Dimensions

Dimension (mm)	DN (mm)									
	50	65	80	100	125	150	200	250	300	
L	203	216	241	292	330	356	495	622	698	
H	295	330	365	400	450	525	595	685	830	
D	178	178	200	254	300	300	348	400	457	
Weight(Kg)	16.5	22.4	29	42.5	62	88.4	143	220	290	

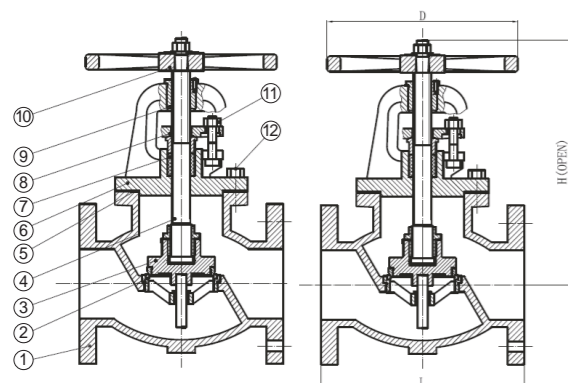

Specification

- Connection Standard: PN16 to EN1092-2/ MSS SP-85
- Nominal Diameter: DN50-DN300
- Medium: water oil gas
- Connection: Flange
- Corrosion Protection: internally and externally liquid epoxy painted

Characteristic Curve

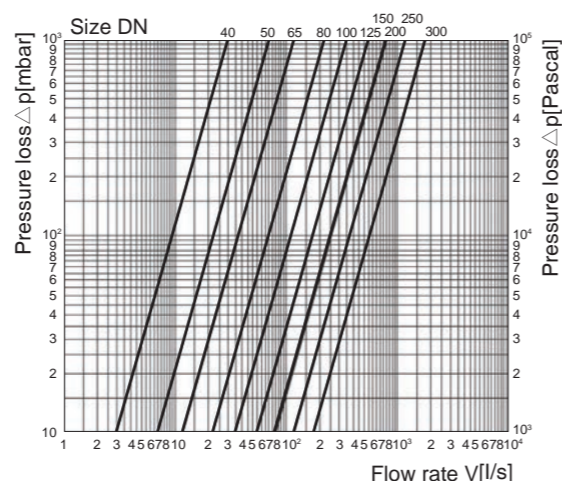

LFSC-EN-201909

Series LFSC

Sillcock Faucets

Size: DN15-DN20

Features

- Lead free, cast brass construction
- Hose bib type faucets with tee handle or hand-wheel
- Ideal for inside and outside installations requiring non-continuous pressure such as general outside gardening and lawn use
- Available with various types of threaded or soldered connections
- Supplied with separate vacuum breaker

Pressure-Temperature

- Nominal Pressure: 125 psi (8.6 bar)
- Temperature Range: 0.5 °C ~82°C continuous

Test Pressures

Hydraulic
100 psi

Models

Tee Handle Sillcock	
LFSC-1	Size 1/2", no kink hose faucet dual inlet connection (male IPS or solder) x 3/4" hose connection
LFSC-2	Size 1/2" or 3/4", no kink hose faucet connection (solder inlet) x 3/4" hose connection
Lawn Faucet Sillcock with Cast Iron Handwheel	
LFSC-3	Size 1/2" or 3/4", solder inlet connection x 3/4" hose connection
LFSC-4	Size 1/2" or 3/4", female IPS connection x 3/4" hose connection
Hose Bibb Hex Shoulder Sillcock with Tee Handle	
LFSC-5	Size 1/2", dual inlet connection (male IPS or solder) x 3/4" hose connection
LFSC-6	Size 3/4", male IPS connection x 3/4" hose connection or 3/4" solder connection x 3/4" hose connection



Specification

- Design Standard: ANSI A112.1.3, ASSE 1011
- Connection Standard: Threaded to ANSI B1.20.1
- NOTE: The information contained here is not intended to replace the full product installation and safety information available or the experience of a trained product installer. You are required to thoroughly read all installation instructions and product safety information before beginning the installation of this product.

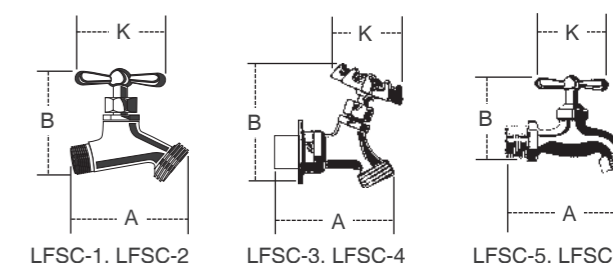

Installation Dimensions

Model	Size	Description	Dimensions			Weight			
			A	B	K	lbs.	kgs		
	in.		in.	mm	in.	mm			
No Kink Hose Faucet with tee handle									
LFSC-1	1/2"	Dual Male IP or Solder connection	2 5/8	67	3	76	2 1/16	52	0.38 0.17
LFSC-2	1/2 or 3/4"	Solder connection	2 5/8	67	3	76	2 1/16	52	0.38 0.17
Lawn Faucet (Sillcock) with cast iron handwheel									
LFSC-3	1/2 or 3/4"	Solder connection	3 1/16	77	3/4	83	2 3/16	56	0.57 0.26
LFSC-4	1/2 or 3/4"	Female IP connection	3 3/16	81	3/4	83	2 3/16	56	0.59 0.27
Hose Bibb Hex Shoulder with tee handle									
LFSC-5	1/2"	Dual Male IP or Solder connection	3 7/16	87	2 3/8	60	2 1/16	52	0.38 0.17
LFSC-6	3/4"	Male IP and solder connection	3 7/16	87	2 1/2	63	2 1/16	52	0.39 0.18



LFSC8-EN-202206

Series LFSC8

Lead Free Cast Brass Hose Bibs with Separate Tamper-proof Vacuum Breaker

Size: DN15-DN20

Watts offers six styles of hose bibs which are supplied with separate vacuum breaker to be attached to the hose bib after hose bib installation. Once the vacuum breaker is properly installed to the hose bib it is tamper-proof. This provides backsiphonage protection for portable hoses connected to hose thread faucets. Garden hoses are an extension of the plumbing system and have been known to cause illness or death when unprotected in uses such as with chemical sprayers, flushing of tanks or pipes, or the filling of pools.

Features

- Backflow backsiphonage protection
- Separate non-removable vacuum breaker (with break-away screw)

Pressure-Temperature

- Nominal Pressure: 100 psi
- Temperature Range: 0.5 °C -82°C continuous

Test Pressure

Hydraulic
100 psi

Models

LFSC8-1	No kink faucet, ½" male NPT or copper sweat connection with vacuum breaker.
LFSC8-2	No kink hose faucet, ¾" copper sweat connection with vacuum breaker.
LFSC8-3	Lawn faucet, ½" or ¾" regular pattern, dual sweat connection with vacuum breaker.
LFSC8-4	Lawn faucet, ¾" female NPT regular pattern with vacuum breaker.
LFSC8-5	Hose bibb hex shoulder, ½" male NPT with tee handle and vacuum breaker.
LFSC8-6	Hose bibb hex shoulder, ¾" male NPT with tee handle and vacuum breaker.

Installation Dimensions

Model	Size	Description	Dimensions			Weight
			A	B	C	
			in.	in.	in.	lbs.
NO KINK HOSE FAUCET with tee handle and vacuum breaker						
SC8-1	½"	Male I.P. or Copper Connection	3 ⅜"	2 ½"	2 ¼"	0.75
SC8-2	¾"	Copper Connection	3 ⅜"	2 ½"	2 ¼"	0.75
LAWN FAUCET (Silcock) with cast iron handwheel and vacuum breaker						
SC8-3	½" or ¾"	Regular Pattern, Dual Connections	3 ¾"	2 ½"	2 ¼"	0.75
SC8-4	¾"	I.P. Regular Pattern	3 ¾"	2 ½"	2 ¼"	0.75
HOSE BIBB HEX SHOULDER with tee handle						
SC8-5	½"	I.P. Inlet Hose End	3 ⅞"	2"	2 ¼"	0.75
SC8-6	¾"	I.P. Inlet Hose End	3 ¾"	2"	2 ¼"	0.75

Note: Models SC8-1 through SC8-5 are packaged with the Model 8B vacuum breaker with break-away set screw. The SC8-6 model is packaged with the Model 8 which has an allen head set screw.



Specification

- Design Standard: ANSI A112.1.3, ASSE 1011
- Connection Standard: ANSI B1.20.1

Approvals

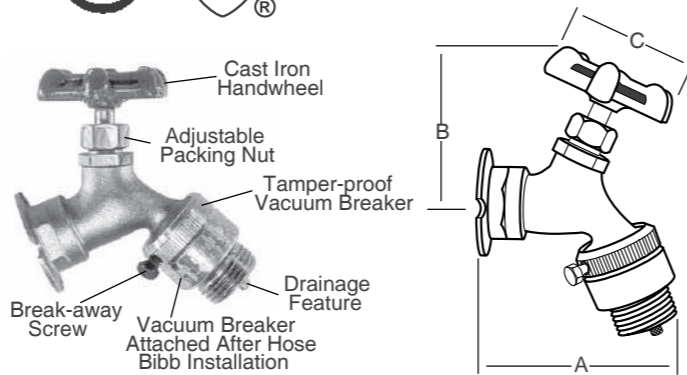

Characteristic Curve

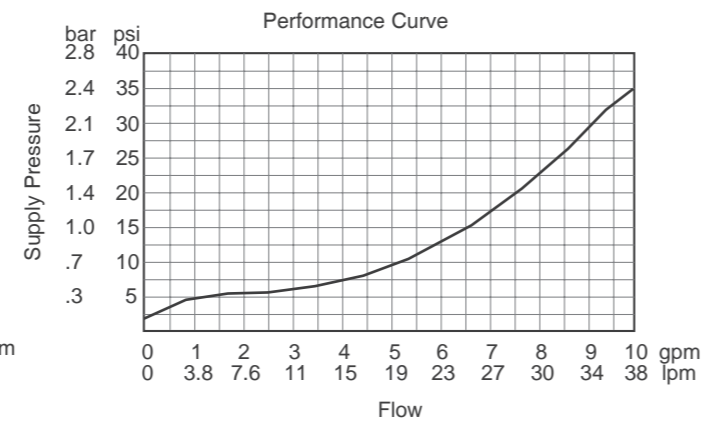

Protection Valves

- Pressure Regulators
- Automatic Control Valves
- Backflow Preventor
- Mixing Valves
- Relief Valves
- Float Valves
- Expansion Tanks





LFN45B/M1-EN-202011

Series LFN45BM1

Sizes: DN15-DN25

Series LFN45B

Sizes: DN32-DN50

Pressure Reducing Valves

The Watts LFN45B Pressure Reducing Valves is designed to reduce the incoming water pressure to a sensible level to protect the system components and reduce water consumption. Its generally used in building services, water treatment etc.

Features

- Integral stainless steel strainer
- Thermoplastic seat & cage
- Lead Free cast copper silicon alloy body construction
- Serviceable in line
- Bypass feature controls thermal expansion pressure
- Sealed spring cage on all models for accessible outdoor or pit installations

Working Principles

After static pressure and dynamic pressure go into valve, adjusting the spring on the upper part of the valve to make the outlet pressure decreased; After the valve pressure expansion, leaking out pressure through the by-pass pipe to ensure the safety of channel; Built-in filter in the valve can filter out impurities when medium go through.

Material

Component	Material
Body	Lead Free Bronze
Seat	Thermoplastic
Bonnet	Thermoplastic
Strainer	SS304
Diaphragm	EPDM
Disc	EPDM

Typical Application

- Water plant and water source project
- Environmental protection
- Municipal facilities
- Electric power and utilities
- Construction industry

Installation Dimensions

LFN45BM1

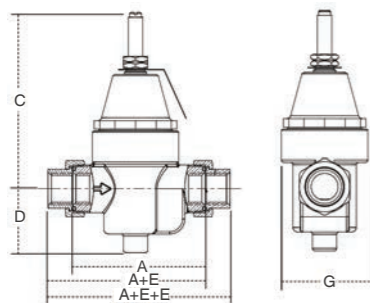

DN	A	C	D	E _{NPT}	G
15	88	116	43	16	57
20	88	116	43	16	57
25	105	116	43	20	57

Pressure - Temperature

- Pressure Reducing Range: 25~75psi(172KPa~517KPa)
- Standard Pressure Setting: 50psi(345KPa)
- Maximum Pressure: LFN45BM1 (DN15-DN25)
400psi(2.76MPa)
LFN45B (DN32-DN50)
300psi(2.07MPa)
- Temperature Range: 0.5°C~82°C

Specification

- Nominal Diameter: DN15~DN50
- Design Standard: ASSE 1003, ANSI A II 2.26.2, CSAB356, IAPMO
- Connection Standard: NPT to ASME B1.20.1
- Working Medium: Water
- Note: Single stage pressure reduction is recommended when incoming pressure is less than 200psi and when reduction ratio is less than 3:1. If the incoming pressure is above 200psi or reduction ratio is more than 3:1(eg. 200psi to50 psi) or when inflow pressure fluctuates greatly, two-stage pressure reduction is recommended by adding PRV in series.

Models

- No Suffix—NPT threaded female inlet x NPT female outlet
- U—NPT threaded union inlet x NPT female outlet
- DU—Double Union – NPT threaded union female inlet and outlet
- G—Gauge tapping option1/8"

Approval



LFN45B

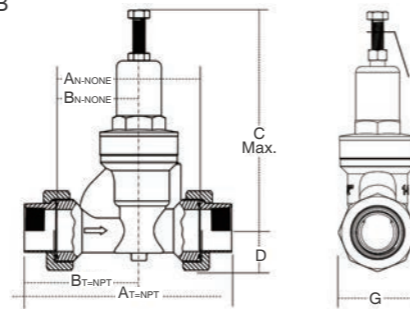

DN	A _T	A _N	B _T	B _N	C	D	G
32	213	148	111	78	225	36	82
40	213	148	115	83	225	41	82
50	228	162	126	93	225	47	93



LFN45B-G-AUS-EN-202101

Characteristic Curves

LFN45BM1 (DN15, DN20, DN25)

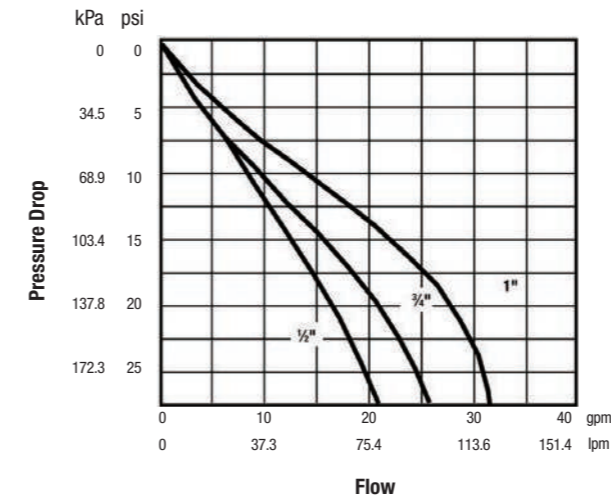

LFN45B (DN32, DN40, DN50)

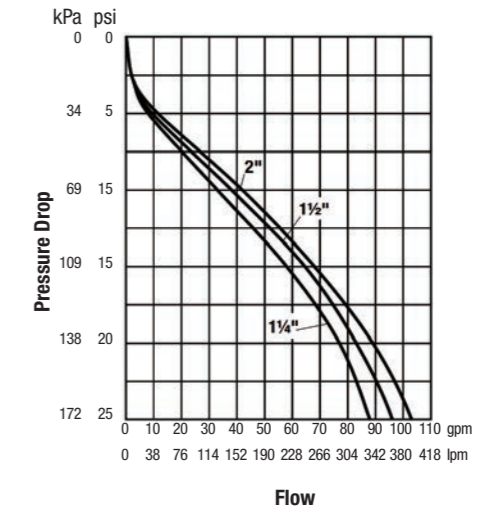

Installation Instructions

1. The valve's rated parameters should match the equipment's. Make sure that the valve's rated flow satisfies the actual demand.
2. The installer must be trained or experienced so as to operate the installation correctly.
3. A thorough check after installation is needed to ensure no errors.
4. A thorough cleaning before installation is needed (chemical reagent can be applied if it is necessary) to ensure that there is not any rusting or dirt in the pipe. All the filters must be removed before washing to keep the pipe smoothly open.
5. When beginning to wash the system, it is suggested to install the valve on a temporary pipe. After finishing system cleaning, move the valve back and install it on the system's pipe.
6. Use threaded connector that meets the standard to connect the valve.
7. The direction of flow must accord with the direction of the arrow head on the valve body.



LF25AUB-Z3-EN-201909

Series LF25AUB-Z3

Pressure Reducing Valve

Size: DN15-DN50

Series LF25AUB-Z3 Water Pressure Reducing Valves are designed to reduce incoming water pressure to a sensible level to protect plumbing system components and reduce water consumption.

Features

- Lead-Free cast copper silicon alloy construction
- High temperature resistant reinforced diaphragm for hot water
- Bypass feature controls thermal expansion pressure
- Standard construction includes Z3 sealed spring cage and stainless steel corrosion resistant adjusting & cage screws
- Union inlet connection
- Integral stainless steel strainer
- Replaceable seat module
- Serviceable in line

Pressure-Temperature

- Nominal Pressure: 300 psi (20.7 bar)
- Temperature Range: 0.5°C–71°C
- Reduced Pressure Range: 25–75 psi

Material

Component	Material
Body	Lead-Free* copper silicon alloy
Seat	1/2"–1" (15–25mm) Replaceable engineered polymer (10% glass filled Noryl®) 1 1/4"–2" (32–50mm) Replaceable stainless steel
Integral Strainer	Stainless steel
Diaphragm	Reinforced EPDM with PTFE wetted surface
Valve Disc	EPDM

Options

Add Suffix	Description
-"	Threaded female union inlet x NPT female outlet
-S	Solder union inlet x NPT female outlet
-QC	Quick-Connect union inlet (1/2", 3/4", 1")
-LF	Double union body less fittings (3/4", 1", 1 1/4")
-w/press****	Press inlet x press outlet (non union)
-DU	Double Union – NPT threaded union female inlet and outlet
-S-DU	Double Union – Solder union inlet and outlet
-DU-PEX	Double Union – PEX union inlet and outlet
-DU-QC	Double Union – Quick-Connect inlet and outlet (1/2", 3/4", 1")
-G	Gauge tapping, 1/4"
-GG	Gauge tapping and 160psi (11 bar) gauge
-HP	High-pressure range 75–125psi (5.2 – 8.6 bar) †
-LP	Low-pressure range 10–35psi (69 – 241 kPa) †
-Z7	400psi (27.6 bar) initial pressure, 1/2" models only
-Z6	Water meter threaded connections and 7 1/2" (190mm) lay length for new or existing meter box installations, For 58", 58" x 3/4" or 3/4" meter setters or resetters



Specification

- Design Standard: ASSE 1003, CSA B356, MIL-V-18146B type I, IAMPO
- Connection Standard: ANSI A112.26.2
- Medium: water, air, neutral gas, domestic fuel oil
- Note: Single Stage Pressure Reduction is recommended where incoming pressure is less than 200psi and when the reduction ratio is less than 3:1. If the initial pressure is 200psi or greater, or the pressure reduction ratio is greater than 3:1 (e.g. from 200psi to 50psi), or when the inflow pressure fluctuates greatly two-stage Pressure reduction is recommended by adding 2 PRVs in series.

Approvals

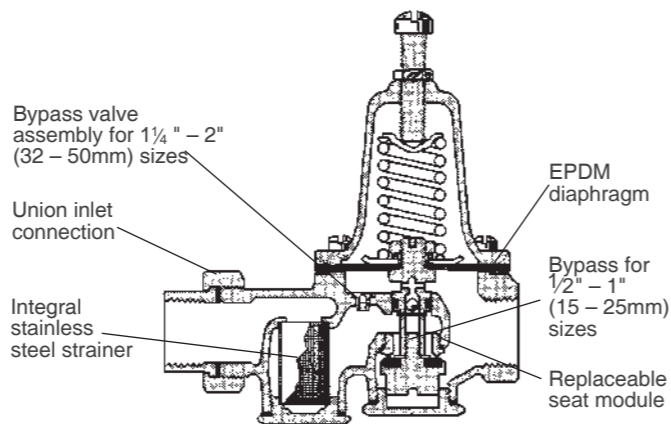

LF25AUB-Z3-EN-201909

Installation Dimension

- A - LF25AUB-Z3
- A1 - LF25AUB-S-Z3
- A2 - LF25AUB-DU-LF-Z3
- B - LF25AUB-DU-Z3
- B1 - LF25AUB-S-DU-Z3
- B2 - LF25AUB-DU-THDXPEX-Z3
- Er - NPT Engagement for tight joint
- Es - Female sweat socket depth
- Ep - PEX end connection
- Foc - Quick-Connect union

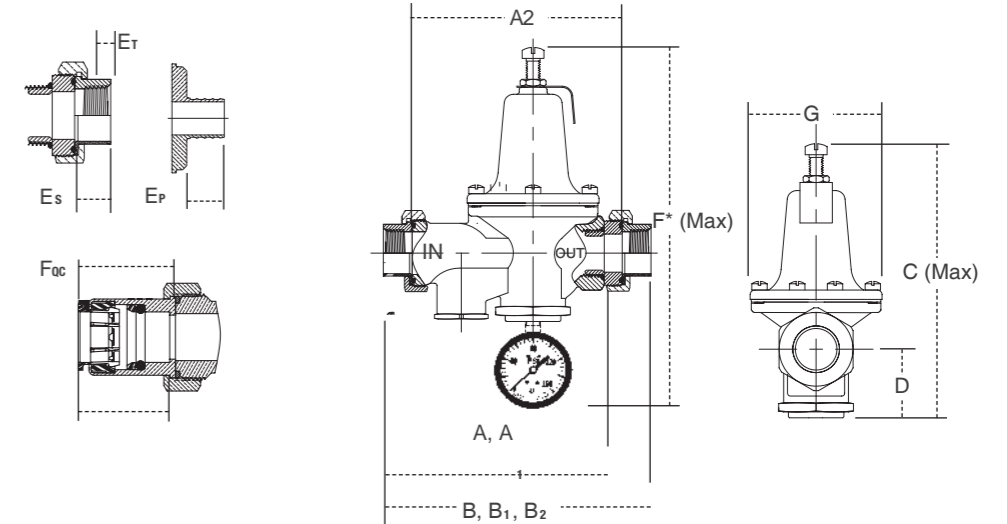

Size	Dimensions													
	A		A1		A2		B		B1		B2		C	
in.	in.	mm	in.	mm	in.	mm	in.	mm	in.	mm	in.	mm	in.	mm
1/2	5 3/8	137	5 5/16	135	5 3/16	132	6 7/16	164	6 3/8	162	-	-	7	178
3/4	5 5/16	135	5 1/2	140	5 1/4	133	6 1/2	165	6 7/8	175	6 3/4	171	7	178
1	6	152	6 1/4	159	5 7/8	149	7 3/8	187	7 13/16	198	7 11/16	195	8	203
1 1/4	8 3/4	222	8 15/16	227	8 1/4	210	10 3/4	273	11	279	-	-	9	229
1 1/2	8 3/4	222	9	229	8 1/4	210	10 3/4	273	11 3/16	284	-	-	9 1/2	241
2	9 1/4	235	10	254	8 3/4	222	11 5/16	287	12 11/16	322	-	-	11 1/4	286

Size	Dimensions															
	D		F ^Δ		G		Er		Es		Ep		Foc		lbs.	kg
in.	in.	mm	in.	mm	in.	mm	in.	mm	in.	mm	in.	mm	in.	mm		
1/2	1 1/2	38	9 7/16	240	3 1/8	79	1/2	13	1/2	13	-	-	1 1/2	38	3.5	1.6
3/4	1 1/2	38	9 7/16	240	3 1/8	79	1/2	13	3/4	19	5/8	16	1 11/16	42	3.5	1.6
1	1 3/4	44	10 7/16	266	3 5/8	92	5/8	16	15/16	23	13/16	21	1 3/4	45	6.5	3.0
1 1/4	2 1/8	54	11 7/16	291	3 5/8	92	5/8	16	1	25	-	-	-	-	10	4.5
1 1/2	2 3/8	60	11 15/16	304	4 1/16	103	5/8	16	1 1/16	28	-	-	-	-	10	4.5
2	3 1/4	83	13 11/16	348	4 3/4	121	5/8	16	1 5/16	34	-	-	-	-	15	6.8

Characteristic Curve

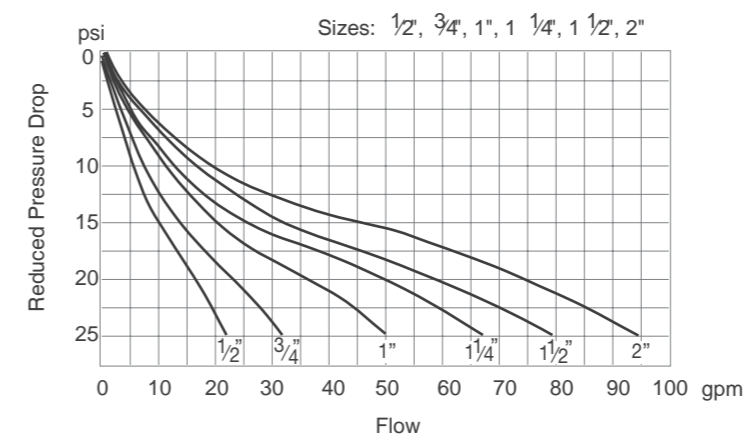



LFN223B-EN-202208

Series LFN223B

Super Capacity Water Pressure Reducing Valve

Sizes: DN65-DN75

Series LFN223B Super Capacity Water Pressure Reducing Valves are designed to reduce incoming water pressure to a sensible level to protect plumbing system components and reduce water consumption. The LFN223B/LFN223BS features Lead Free* construction to comply with Lead Free* installation requirements. This series is suitable for water supply pressures up to 300psi (20.7 bar) and may be adjusted from 25 – 75psi (172 – 517 kPa). The standard setting is 50psi (345 kPa). Series LFN223B features an enlarged diaphragm, spring cage and seat orifice for super capacity performance.

Features

- Enlarged diaphragm, spring cage and seat orifice for super capacity performance
- Lead Free* cast copper silicon alloy body construction
- Serviceable in line
- Series LFN223BS furnished with separate Lead Free* strainer
- Standard bypass feature controls thermal expansion pressure****
- Sealed spring cage on all models for accessible outdoor or pit installations

Pressure - Temperature

- Temperature Range: 33°F – 160°F (0.5°C – 71°C)
- Maximum Working Pressure: 300psi (20.7 bar)
- Adjustable Reduced Pressure Range: 25 – 75psi (172 – 517 kPa)
- Standard Reduced Pressure Setting: 50psi (345 kPa)

Material

Component	Material
Body	Lead Free* cast copper silicon alloy
Seat	Replaceable stainless steel alloy
Strainer Screen	Stainless steel (model LFN223S)
Diaphragm	Reinforced Buna-N
Valve Disc	EPDM

Models

- 2½" LFN223M2-B** NPT threaded female inlet x NPT threaded female outlet
- 3" LFN223M1-B** NPT threaded female inlet x NPT threaded female outlet
- 2½" LFN223M2-BS** NPT threaded female inlet with strainer x NPT threaded female outlet
- 3" LFN223M1-BS** NPT threaded female inlet with strainer x NPT threaded female outlet

For ½" – 2½" threaded connections, refer to literature ES-LF223. For 3" flanged connections, refer to literature ES-LF223F.

Installation Dimensions

DN(in)	C(mm)	D(mm)	L(mm)	WEIGHT(kgs)
2½"	273	73	200	13.6
3"	324	105	267	32.2

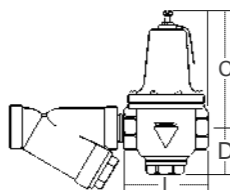

Approvals

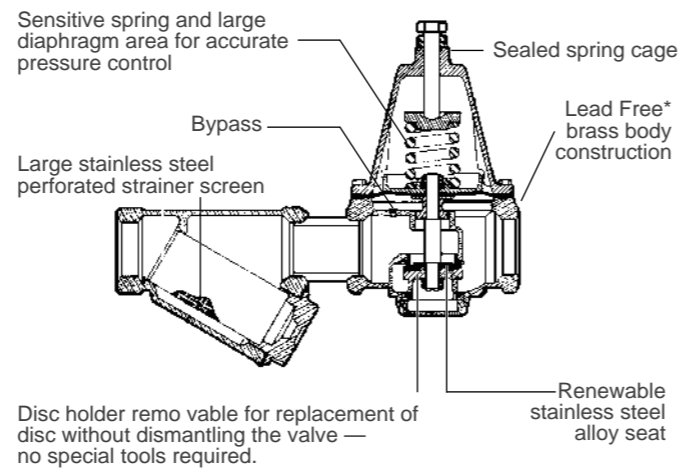

Characteristic Curve

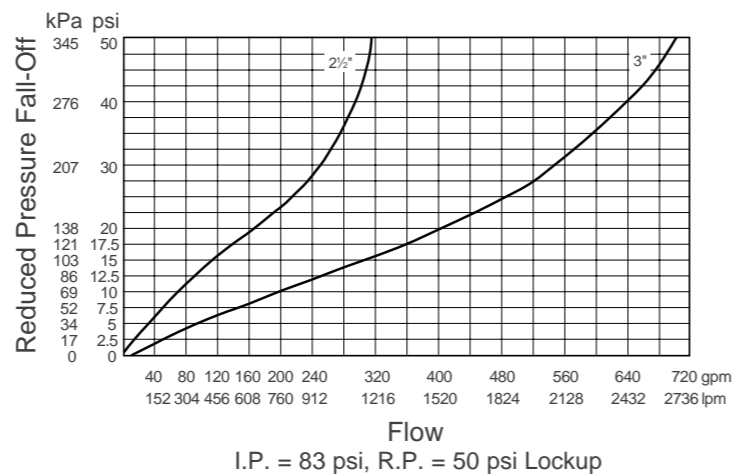

DRV-EN-202212

Series DRV

Pressure Reducing Valve

Size: DN15-DN50

The DRV Series pressure reducing valves are devices capable of reducing the pressure of the fluid downstream to a desired level and keeping it constant even in the presence of major variations in the flow rate and/or pressure upstream, by modifying its pressure drops.

Pressure - Temperature

- Maximum upstream pressure: 25 bar
- Maximum operating temperature DRV: 60°C (30°C DVGW)

Material

Component	Material
Body	Sand blasted CW617N
Cap	Sand-blasted/(DRV) CW617N, Reinforced polymer (DRVN)
Plug	Brass CW617N
Inlet/outlet connections	Brass CW617N
Diaphragm	NBR reinforced with nylon fabric compliant with KTW and W270 - KTW
Seal and O-Ring	NBR - KTW - W270
Spring	Galvanized steel
Adjusting screw and lock nut	Brass CW617N
Filters	Stainless steel

Installation Dimensions

DN	L	L1	H	H1
1/2"	97	152	136	48
3/4"	110	171	155	58
1"	114	175	176	66
1.1/4"	140	211	227	75
1.1/2"	159	245	253	82
2"	175	261	263	88

Characteristic Curve

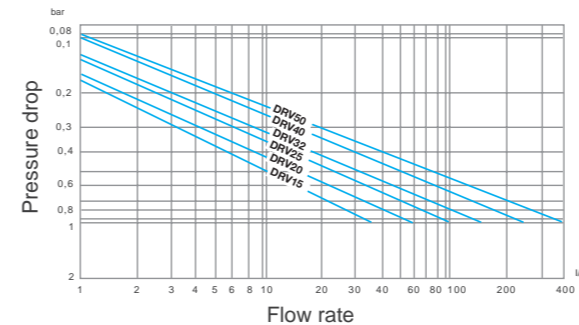

Specification

- Design Standard: EN1567
- Downstream pressure (outlet): 1.5-6 bar
- Connections: M/M tailpiece
- Downstream pressure adjustment (screw 4): Clockwise rotation: increases pressure Anticlockwise rotation: decreases pressure

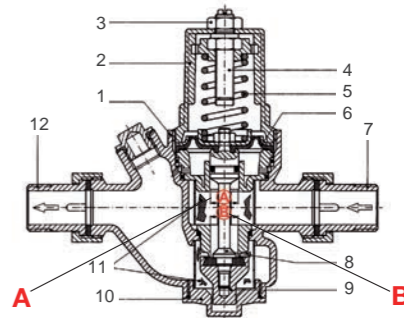

Fig.1

Features:

- 1 Body
- 2 Cap
- 3 Lock nut
- 4 Setting screw
- 5 Spring
- 6 Diaphragm
- 7 Inlet connection
- 8 Pin
- 9 Plug
- 10 Guide bushing
- 11 Filters
- 12 Outlet connection



DRVN-EN-202208

Series DRVN

Patented Diaphragm Pressure Reducing Valve

Size: DN15-DN50

The DRVN Series pressure reducing valves are devices capable of reducing the pressure of the fluid downstream to the desired level and keeping it constant even in the presence of major variations in the flow rate and/or pressure upstream, by modifying its pressure drops.

Features

- Patented Diaphragm PRV
- Stainless steel integral strainer
- Pressure gauge connection on both sides: 1/4"
- Materials in contact with fluids KTW certified
- Noise < 20 dB
- Unions are included

Pressure-Temperature

- Nominal Pressure: PN25
- Operating Temperature: 60°C

Typical Application

- Sanitary systems
- Compressed air systems
- Downstream of storage tanks or cylinders

Material

NO.	Component	Material
1	Body	Sand blasted brass
2	Cap	Reinforced polymer
3	Adjustment knob	Reinforced Polymer
4	Setting screw	Brass
5	Spring	Galvanized steel
6	Diaphragm	NBR reinforced with nylon fabric compliant with KTW and W270-KTW
7	Inlet connection	Brass
8	Pin	Brass
9	Plug	Brass
10	Filters	Stainless steel
11	Outlet connection	Brass

Installation Dimensions

DN	L	L1	H	H1	Weight (kg)
1/2"	84	135	113	16.5	0.6
3/4"	94	151	133	20.5	0.9
1"	104	161	140	26	1.3
1.1/4"	109	175	192	29.5	2.1
1.1/2"	134	214	200	36	3.4
2"	144	224	205	42	4.2



Specification

- Design Standard: EN1567
- Connection Standard: DIN-ISO 228/1
- Connection Type: Male x Male
- Pressure Reducing Range: 1.5 to 6 bar
- Pressure drop less than 1.3 bar at characteristic flow rate
- Available option with M3A-ABS50 pressure gauge, Model DRVMN
- Medium: water, air and neutral gases

Approval

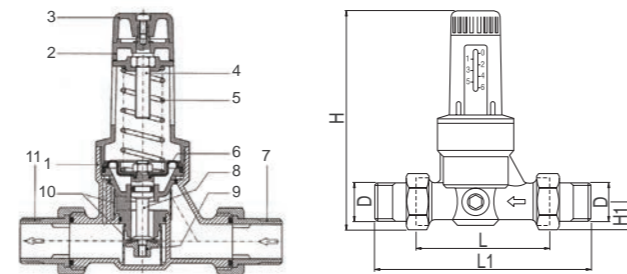

Characteristic Curve

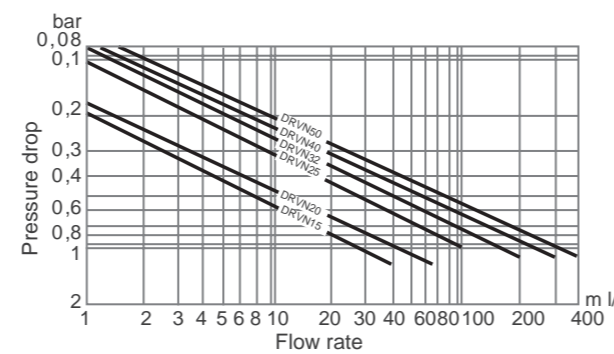

DRVM-EN-202212

Series DRVM

Pressure Reducing Valve

Size: DN15-DN50

The DRVM Series pressure reducing valves are devices capable of reducing the pressure of the fluid downstream to a desired level and keeping it constant even in the presence of major variations in the flow rate and/or pressure upstream, by modifying its pressure drops. DRVM is a same pressure reducing valve as that of DRV model, however it comes with M1-ABS-50 Series pressure gauge (Scale 0-6 bar).

Pressure - Temperature

- Maximum upstream pressure: 25 bar
- Maximum operating temperature DRVM: 60°C (30°C DVGW)

Material

Component	Material
Body	Sand blasted CW617N
Cap	Sand-blasted/(DRV) CW617N, Reinforced polymer (DRVN)
Plug	Brass CW617N
Inlet/outlet connections	Brass CW617N
Diaphragm	NBR reinforced with nylon fabric compliant with KTW and W270 - KTW
Seal and O-Ring	NBR - KTW - W270
Spring	Galvanized steel
Adjusting screw and lock nut	Brass CW617N
Filters	Stainless steel

Installation Dimensions

DN	L	L1	H	H1
1/2"	97	152	136	48
3/4"	110	171	155	58
1"	114	175	176	66
1.1/4"	140	211	227	75
1.1/2"	159	245	253	82
2"	175	261	263	88

Characteristic Curve

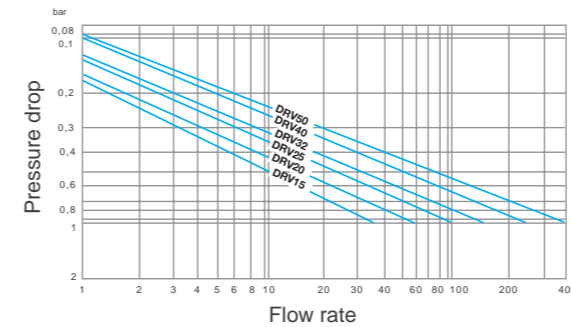

Specification

- Design Standard: EN1567
- Downstream pressure (outlet): 1,5÷6 bar
- Connections: M/M tailpiece
- Downstream pressure adjustment (screw 4): Clockwise rotation: increases pressure Anticlockwise rotation: decreases pressure

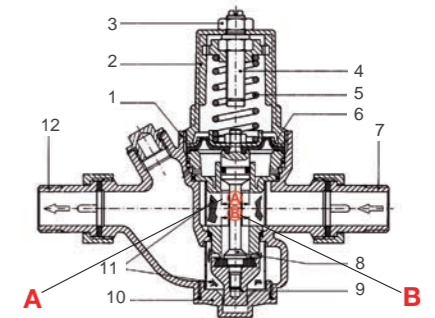

Fig.1

Features:

- 1 Body
- 2 Cap
- 3 Lock nut
- 4 Setting screw
- 5 Spring
- 6 Diaphragm
- 7 Inlet connection
- 8 Pin
- 9 Plug
- 10 Guide bushing
- 11 Filters
- 12 Outlet connection



DRVMN-EN-202208

Series DRVMN

Patented Diaphragm Pressure Reducing Valve

Size: DN15-DN50

The DRVN Series pressure reducing valves are devices capable of reducing the pressure of the fluid downstream to the desired level and keeping it constant even in the presence of major variations in the flow rate and/or pressure upstream, by modifying its pressure drops.

Features

- Patented Diaphragm PRV
- Stainless steel integral strainer
- Pressure gauge M3A-ABS50 series (scale 0-6 bar)
- Materials in contact with fluids KTW certified
- Noise < 20 dB

Pressure-Temperature

- Nominal Pressure: PN25
- Operating Temperature: 60°C

Material

NO.	Component	Material
1	Body	Sand-blasted brass
2	Cap	Reinforced polymer
3	Adjustment knob	Reinforced Polymer
4	Setting screw	Brass
5	Spring	Galvanized steel
6	Diaphragm	NBR reinforced with nylon fabric compliant with KTW and W270 - KTW
7	Inlet connection	Brass
8	Pin	Brass
9	Plug	Brass
10	Filters	Stainless steel(SS304)
11	Outlet connection	Brass

Installation Dimensions

DN	L	L1	H	H1	Weight(kg)
1/2"	84	135	113	16.5	0.7
3/4"	94	151	133	20.5	1.0
1"	104	161	140	26	1.4
1 1/4"	109	175	192	29.5	2.2
1 1/2"	134	214	200	36	3.5
3"	144	224	205	42	4.3

Characteristic Curve

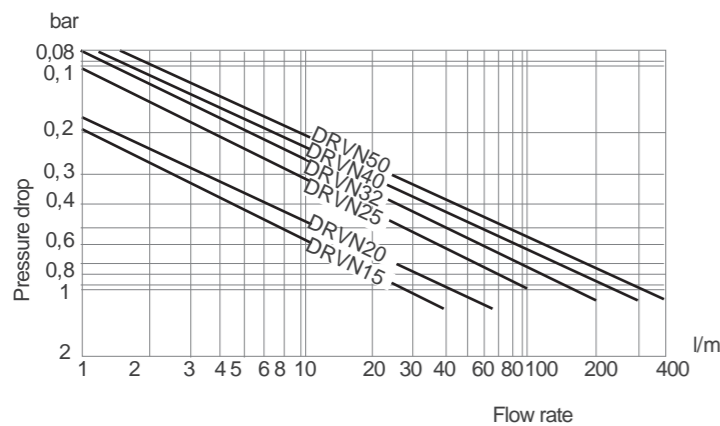

Specification

- Design Standard: EN1567
- Connection Standard: DIN-ISO228/1
- Pressure Reducing Range: 1.5 to 6 bar
- Pressure drop less than 1.3 bar at a characteristic flow rate
- Mediums: water, air, and neutral gases

Approval

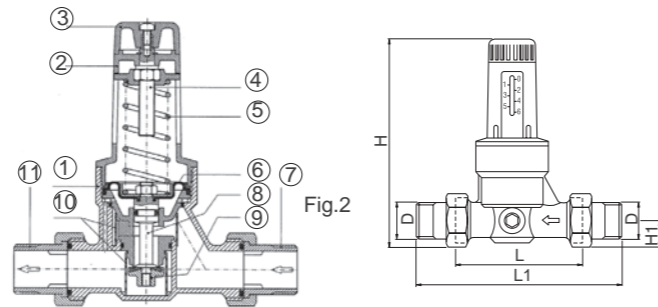

Cavitation Chart

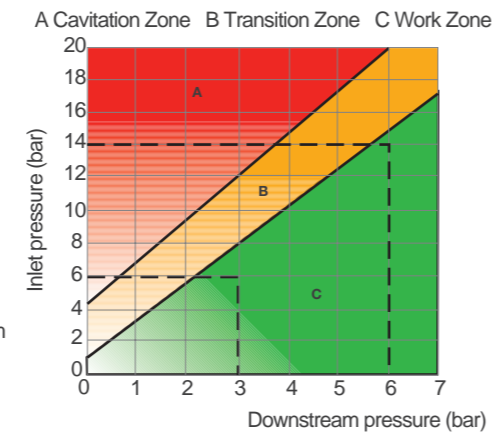

DRVD-EN-201909

Series DRVD

Flanged Pressure Reducing Valve

Size: DN50-DN200

The pressure reducing valve DRVD can be used on water, compressed air, air with oil removed or all neutral gases. It maintains automatically the downstream to the set point pressure, as long as the input pressure is greater. The DRVD is insensitive to variations in upstream pressure. It is particularly recommended for collective or industrial installations.

Features

- Cast Iron body
- Model with balanced valve and piston
- Very high reliability and longevity
- Ideal for any main pressure reducing or regulation of secondary circuits

Pressure-Temperature

- Nominal Pressure: PN16/25
- Temperature Range: 0°C-40°C

Material

No	Component	Material
1	Body	Cast iron G.S.
2	Cover	Cast iron G.S.
3	Flange	Cast iron
4	Spring disc	Cadmium steel
5	Seal support	Brass
6	Shutter	Brass
7	Jacket	Bronze
8	Ring	Bronze
9	Seat	Bronze
10	Setting screw	Cadmium steel
11	Spring	Costed steel
12	Brace washer	NBR
13	Seal	NBR
14	Seal	NBR
15	Cover screw	Stainless steel
16	Nut	Cadmium steel
17	Plug	Brass

Installation Dimensions

Models	DN	L (mm)	H (mm)	h (mm)	F (mm)
DRV-D50	50	230	300	83	165
DRV-D65	65	290	350	90	185
DRV-D80	80	310	390	100	200
DRV-D100	100	350	440	121	220
DRV-D125	125	400	560	152	250
DRV-D150	150	450	670	169	285
DRV-D200	200	550	1050	234	340



Specification

- Design Standard: EN1567
- Connection Standard: Flanged to EN 1092-2, ISO 7005-2
- Test Standard: EN 12266

Typical Application

- Sanitary systems
- Compressed air systems
- Downstream of storage tanks or cylinders

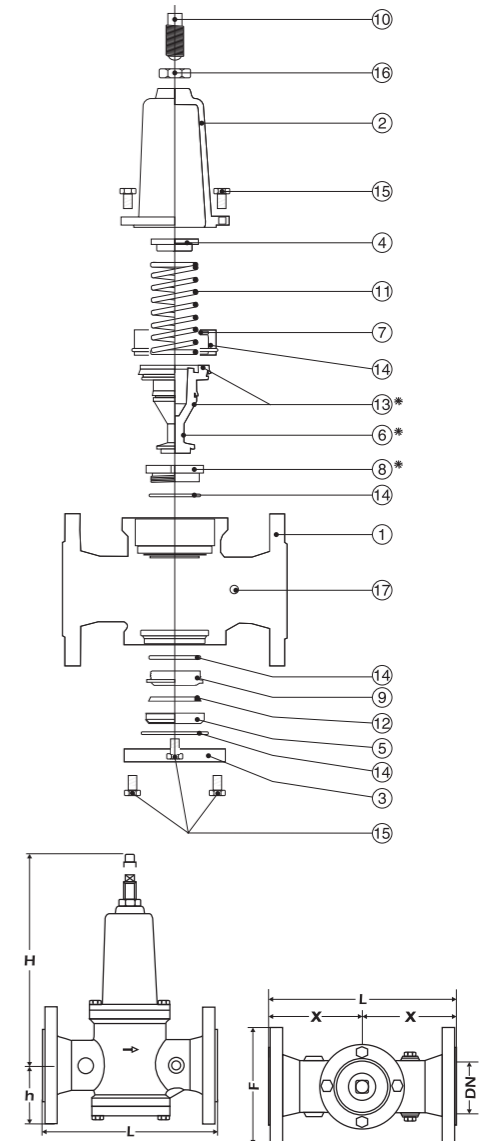

Technical Description

Flanged pressure reducing valve DRVD PN16

Diameter	Setting Range	Type	Ref. Code	Packaging
DN50	1,5 to 6 bar	DRVD PN16	L 05.04.053	1
DN65	1,5 to 6 bar	DRVD PN16	L 05.04.068	1
DN80	1,5 to 6 bar	DRVD PN16	L 05.04.083	1
DN100	1,5 to 6 bar	DRVD PN16	L 05.04.103	1
DN125	1,5 to 6 bar	DRVD PN16	L 05.04.128	1
DN150	1,5 to 6 bar	DRVD PN16	L 05.04.153	1
DN200 (on request)	1,5 to 6 bar	DRVD PN16	L 05.04.203	1

Characteristic Curves

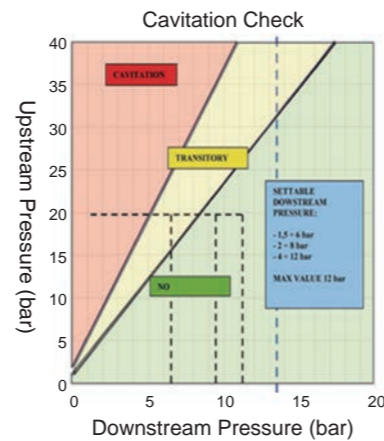
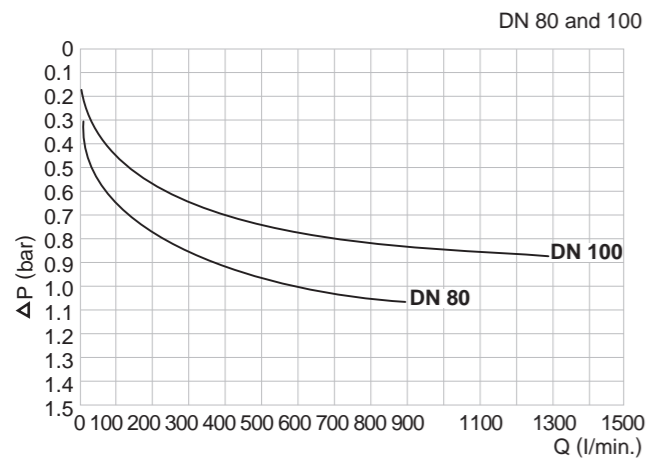
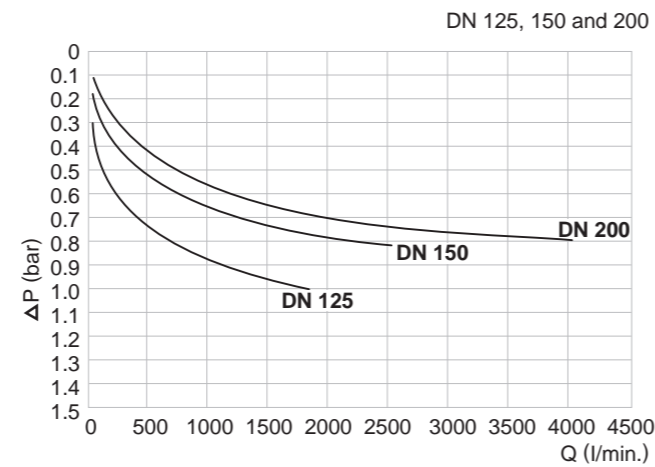
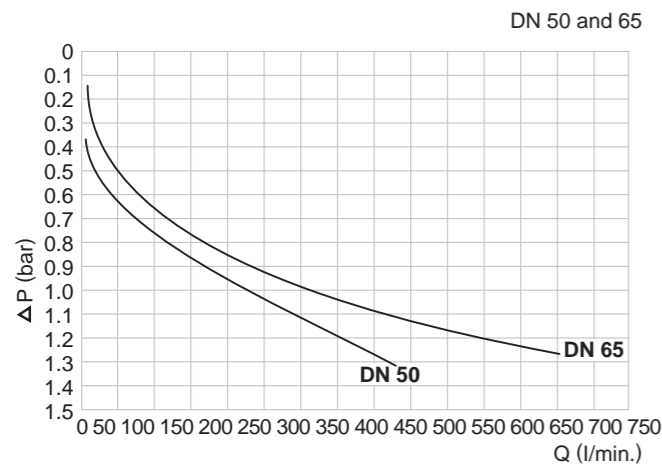

Flanged pressure reducing valve DRVD PN25

Identical model to the standard DRVD above but PN25 and standard setting from 4 to 12 bar. Contact us for the delivery time.

Diameter	Setting Range	Type	Ref. Code	Packaging
DN50	4 to 12 bar	DRVD PN25	L 05.04.050	1
DN65	4 to 12 bar	DRVD PN25	L 05.04.065	1
DN80	4 to 12 bar	DRVD PN25	L 05.04.080	1
DN100	4 to 12 bar	DRVD PN25	L 05.04.100	1
DN125	4 to 12 bar	DRVD PN25	L 05.04.125	1
DN150	4 to 12 bar	DRVD PN25	L 05.04.150	1

Series 7BIS

Pressure Reducing Valve

Size: DN15-DN50

Features

- Control and maintain the downstream pressure at an adjustable reduced value, whether there is a flow or not.
- Keep an outlet pressure at a constant value, even by variation of the upstream pressure (the down-stream pressure cannot vary more than 10 % of the variation of the upstream pressure, according to the Standard).
- No maintenance required, not affected by scale or dirt
- Can be installed in any position
- Guarantee a high flow rate at a constant outlet pressure because of low head loss

Pressure-Temperature

- Nominal Pressure: PN25
- Temperature Range: -10 °C ~ 80 °C
- Reduced Pressure Range: 1 to 5.5 bar

Material

NO.	Component	Material
1	Casing	Bronze
2	Stem	DZR brass
3	Seal Box	Brass
4	Seal DN 15-20	EPDM
5	Membrane	NBR/Polyamide
6	Membrane Washer	Brass
7	Nut	Stainless Steel(SS304)
8	Spring	Anti-corrosive Steel
9	Cap	Brass
10	Screw	Stainless Steel(SS304)
11	Adjusting Screw	Brass
12	Cap Cover	Brass
13	O-Ring	NBR (Nitrile)
14	Pressure Gauge Cap	Brass
15	Flat Ring	NBR (Nitrile)
16	Plug	Plastic

Characteristic Curve

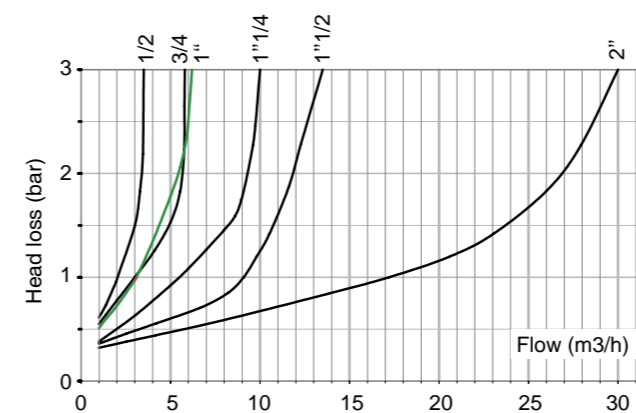

Kv : Flow in m3/h when the outlet pressure become 1 bar lower than its setting at zero.



Specification

- Design Standard: EN 1567
- Connection Standard: Threaded to NF EN ISO 228
- Test Standard: EN 1567
- Preset Pressure: 3 bar
- Equipped with 2 plugs 1/4" on each side to allow the mounting of downstream pressure gauge and drain
- Medium: water, air - neutral gas, domestic fuel

Approval

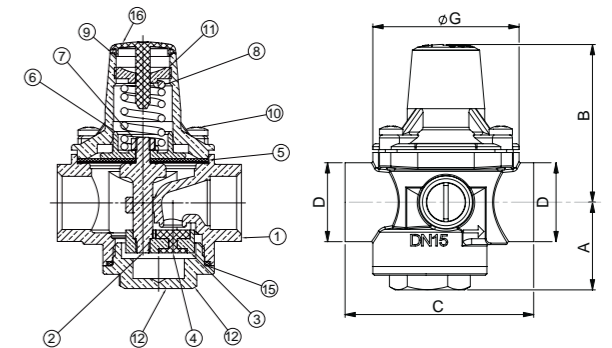

Installation Dimensions

DN	D mm	A mm	B mm	C mm	G mm	Weight kg	Kv mm	Q max mm	Q at 2m/s mm
15	15/21	30	56	64,5	50	0,5	2	3,5	1,27
20	20/27	33,5	61	70	57	0,6	3	5,8	2,26
25	26/34	30	68	81	70	0,95	3,1	6,2	3,53
32	33/42	34,5	91	97	81	1,55	5,5	10	5,8
40	40/49	36,5	106	110	92	2,05	9,3	13,5	9
50	50/60	45,5	106	135	120	3,70	17,4	30	14



10BIS-EN-202212

Series 10BIS/ 10BIS RC

Pressure Reducing Valve

Size: DN10-DN100

Features

- Control and maintain the downstream pressure at an adjustable reduced value, whether there is a flow or not
- Keep an outlet pressure at a constant value, even by variation of the upstream pressure
- No maintenance required, not affected by scale or dirt
- Guarantee a high flow rate at a constant outlet pressure because of low head loss
- Downstream pressure gauge connection: 1/4"

Pressure - Temperature

- Nominal Pressure: 25 bar
- Temperature Range: -10°C ~80°C
- Pressure Reducing Range: 1 to 6 bar

Material

NO.	Component	Material
1	Casing	Bronze
2	Spring	Anticorrosive steel
3	Nut For Spring Pressing	Brass
4	Cap	Brass or alu-bronze or bronze
5	Cap Cover	Brass or bronze
6	Seal	NBR (Nitrile) or fiber
7	Screw	Stainless steel
8	Membrane	NBR/Polyamide (Nitrile)
9	Plate	Brass or bronze
10	Stirrup	Alu-Bronze DZR brass or Bronze
11	Flat Seal	NBR (Nitrile)
12	Screw	Stainless steel
13	Seal	NBR (Nitrile) or fiber
14	Pressure Gauge Cap	DZR brass
15	Adjusting Screw	Stainless steel
16	Nut	Stainless steel
17	Compensating Spring	Stainless steel

Installation Dimensions

DN	D		A	B	C	G	Weight (kg)
	"	mm					
10	3/8	12/17	48	120	92	92	1,25
15	1/2	15/21	48	120	92	92	1,25
20	3/4	20/27	55	130	108	108	1,75
25	1	26/34	60	160	123	123	2,70
32	1 1/4	33/42	77	180	155	155	4,30
40	1 1/2	40/49	84	205	172	172	5,60
50	2	50/60	105	235	198	198	9,80
65	2 1/2	66/76	118	270	215	215	13,50
80	3	80/90	143	300	234	234	17,90
100	4	102/114	120	350	250	260	33,60



Specification

- Design Standard: EN 1567
- Test Standard: EN 1567
- Connection Standard: BSPT to NF EN ISO 228
- Preset Pressure: 3 bar
- Available with compensating spring: type 10BIS RC, for lower downstream pressure
- Medium: water, air, neutral gas, and domestic fuel oil

Approvals

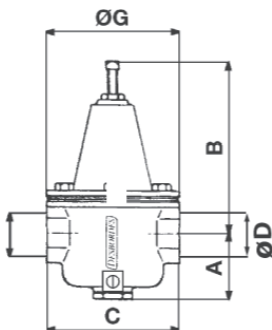
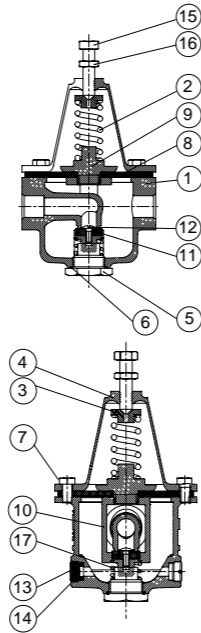

11BIS-EN-202212

Series 11BIS/ 11 BIS RC

Pressure Reducing Valve

Size: DN15-DN50

Features

- Control and maintain the downstream pressure at an adjustable reduced value, whether there is a flow or not
- Keep an outlet pressure at a constant value, even with variation of the upstream pressure
- No maintenance required, not affected by scale or dirt
- Guarantee a high flow rate at a constant outlet pressure because of low head loss
- 1/4" pressure gauge connection and drain at both sides of the casing

Pressure - Temperature

- Nominal Pressure: PN25
- Temperature Range: -10°C ~80°C
- Pressure Reducing Range: 1 bar to 5.5 bar

Material

NO.	Component	Material
1	Casing	Bronze
2	Pressure Gauge Cap	Brass
3	Seal	NBR (Nitrile)
4	Seat	Stainless steel
5	O-ring	NBR (Nitrile)
6	Stirrup DN 15 - 25 mm DN 32 - 50 mm	Brass
7	Flat Seal	NBR (Nitrile)
8	Guide Plate	Brass
9	Cap Cover	Brass
10	Spring	Anticorrosive steel
11	Cap DN 15 - 25 mm DN 32 - 50 mm	Brass
12	Screw	Stainless steel
13	Membrane	NBR/Polyamide
14	Plate	Brass
15	Membrane Screw	Stainless steel
16	Adjusting Screw	Brass
17*	Nut For Spring Pressing	Brass
18	O-ring	NBR (Nitrile)
19	Copper Washer	Copper
20	Compensating Spring	Stainless steel

* Type 11bisrc only (DN 15 and 20)

Installation Dimensions

DN	D		A	B	C	G	Weight (kg)	Kv
	mm	mm						
15	15/21	31	60	59	66	66	0.7	3
20	20/27	32	75	73	76.5	76.5	0.9	4.5
25	26/34	40	102	94	98	98	1.9	8
32	33/42	51	179	104	126	126	3.9	12
40	40/49	46	185	104	132	132	4.2	15
50	50/60	54	194	104	146	146	5.2	16



Specification

- Design Standards: EN 1567
- Test Standard: EN 1567
- Thread Connection: female/female BSPT to NF EN ISO 228
- Standard Pressure: Pre-set at 3 bar
- Available with Compensating Spring: type 11 bis RC, for lower downstream pressure (DN15, DN20)
- Medium: water, air, neutral gas, and domestic fuel oil

Approvals

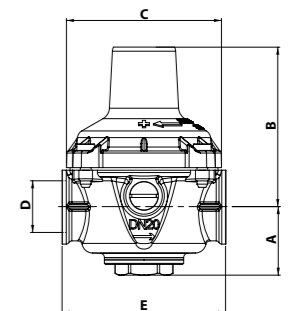
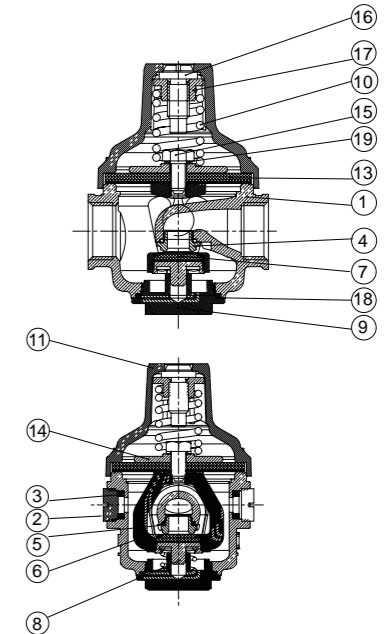



W-M115-EN-202212

Series W-M115

Ductile Iron Pressure Reducing Valve

Size : Thread DN32-DN50 Flange DN50-DN300

The Watts W-M115 Pressure Reducing Valve is designed to adjust, set and maintain downstream pressure of the pipeline. It's generally used in city water supply, industrial and agricultural water transmission pipeline, etc.

Features

- Stable performance, safe and reliable
- Simple operation, convenient adjusting
- Precise pressure reducing
- Long service life
- Working Medium: water

Pressure - Temperature

- Nominal Pressure: PN16/CL150/CL300
- Temperature Range: 0°C ~ 80°C
- Float Valve Working Pressure: 116Psi (8Bar)
- Minimum Different Pressure: 5Psi(0.035MPa)

Test Pressures

Class	Pneumatic	Hydraulic
PN16	Seat: 7 bar	Shell: 24 bar Seat: 17.6 bar
CL150	Seat: 7 bar	Shell: 25.2 bar
CL300	Seat: 7 bar	Shell: 40 bar

Material

NO.	Component	Material
1	Cover	Ductile Iron+Epoxy Coated
2	Cover Bearing	Stainless Steel
3	Shaft/Stem	Stainless Steel
4	Stud	Zinc Plated Steel/Stainless Steel
5	Cover Nut	Zinc Plated Steel/Stainless Steel
6	Washer	Zinc Plated Steel/Stainless Steel
7	Diaphragm	Buna N(Nitrile)+Nylon
8	Spring	Stainless Steel
9	Disc Retainer	Ductile Iron+Epoxy Coated
10	Seat Disc	Buna-N(Nitrile)
11	Body	Ductile Iron+Epoxy Coated
12	Plug	Brass/Zinc Plated Steel
13	Stem Nut	Stainless Steel
14	LockWasher	Stainless Steel
15	Spring Washer	Stainless Steel
16	Diaphragm Washer	Ductile Iron+Epoxy Coated
17	Spacer Washer Fiber	Fiber
18	Disc Guide	Stainless Steel
19	Seat O-Ring	Buna N(Nitrile)
20	Seat Ring	Stainless Steel



Specification

- Design Standard: AWWA C530
- Connection Type: Thread & Flanged is available
W-M115-BSPT CL 300 BSPT to ISO 7-1
W-M115-Flange to PN16 to BS EN 1092-2 & CL150 to ANSI B16.42 & CL300 to ANSI B16.42
- Test Standard: ISO/DIS 5208:2007
- Pressure Reducing Range:
Standard: LF26A--10Psi~125Psi
(0.07MPa~0.9MPa)(Pilot valve)
Optional : LF263AP--20Psi~175Psi(0.137Mpa~1.2Mpa)
LFCP15--30Psi~300Psi(0.206Mpa~2.06Mpa)
- Pressure Gauge: 0-350Psi
- Standard Pressure Setting: 50Psi (0.35MPa)

Approval



Mustang Series Main Valve

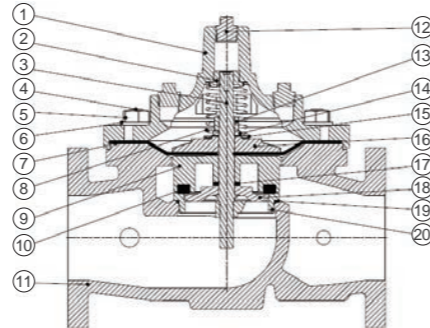

EU Series Main Valve

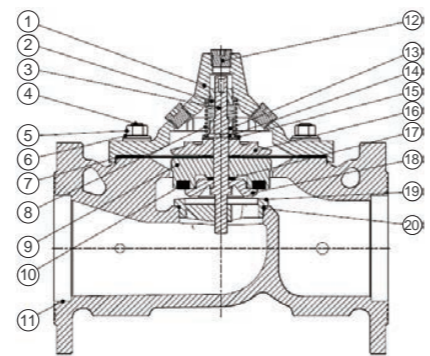

W-M115-EN-202212

Installation Dimensions

Connection Dimension: PN16 to BS EN 1092-2

Size DN (mm)	Dimensions(mm)					Flange Dimensions(mm)			Weight (Kg)
	L	H	H1	B	C	n-ØD	E	T	
32 BSPT	184	305	271	235	/	/	/	/	17.5
40 BSPT	184	305	271	235	/	/	/	/	17.5
50 BSPT	238	315	268	250	/	/	/	/	18.2
50	230	325	245	260	125	4-Ø19	165	19	18.6
65	290	343	250	265	145	4-Ø19	185	19	19.2
80	310	345	245	275	160	8-Ø19	200	19	20.1
100	350	395	285	345	180	8-Ø19	220	19	36.5
125	400	413	288	380	210	8-Ø19	250	19	58.6
150	480	430	288	405	240	8-Ø23	285	19	72
200	600	540	370	475	295	12-Ø23	340	20	140
250	660	650	450	560	355	12-Ø28	406	30.5	265
300	762	755	520	670	410	12-Ø28	482	31.8	465

*Please contact the local salesmen if the size ≥DN300 is needed.

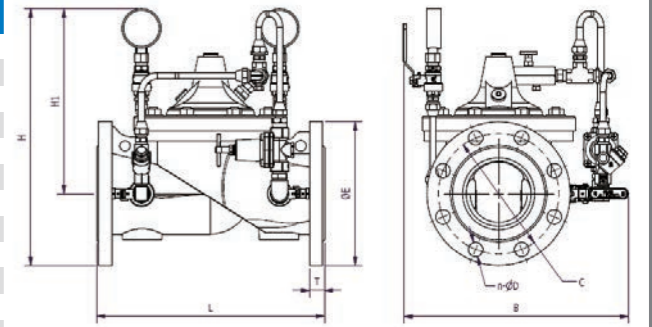

Flow Rates

Size (DN)	32	40	50	65	80	100	150	200	250	300
Maximum Continuous (GPM)	95	130	210	300	485	800	1850	3100	5000	7000
Maximum Intermittent (GPM)	119	161	265	390	590	1000	2300	4000	6250	8725
Minimum Continuous (GPM)	1	1	1	20	30	50	115	200	300	400
CV Factor GPM (Globe)	25	30	45	75	100	175	490	770	1200	1750

Characteristic Curves

Full Port Series

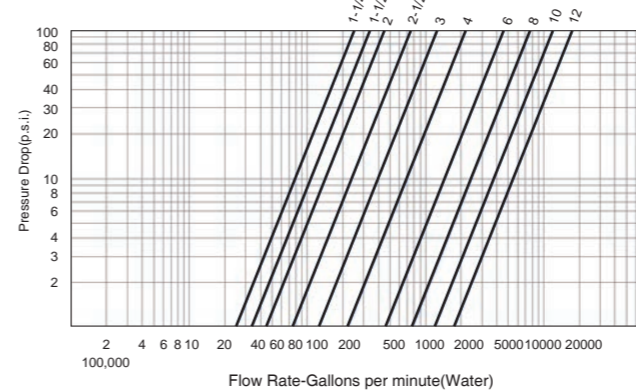

Reduce Port Series

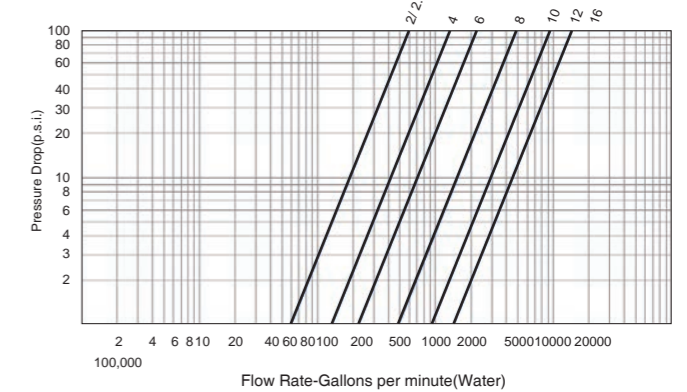

Cavitation Chart

After selecting the valve size, locate inlet and outlet pressure on this chart. If the intersection point falls in the shaded area, cavitation can occur. Operation of valves continually in the cavitation zone should be avoided. Consult Watts ACV for alternatives.

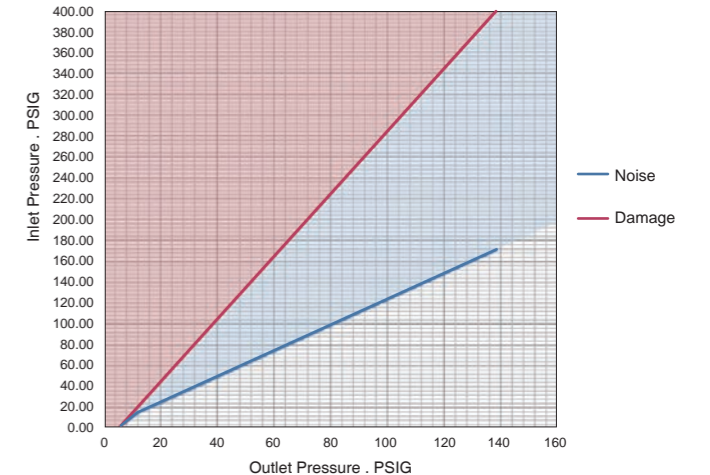



W-M115-74-EN-202212

Series W-M115-74

Pressure Reducing Valve - Lowflow Bypass

**Size: Thread DN32-DN50
Flange DN50-DN200**

The WATTS ACV Pressure Reducing Control Valve with low flow By-Pass is designed to automatically reduce a fluctuating higher upstream pressure to a constant lower downstream pressure regardless of varying flow rates. Flow requirements below the normal range of the mainline Pressure Reducing Control Valve is handled by a separate, valve mounted, direct acting, Low Flow By-Pass Pressure Reducing Valve.

Features

- Throttles to reduce high upstream pressure to constant lower downstream pressure
- Low flow By-Pass controls at low flows
- Mainline valve controls at high flows
- Reducing and low flow By-Pass setpoints are separately adjustable

Pressure - Temperature

- Nominal Pressure: PN16
- Temperature Range: 0°C~ 80°C

Test Pressures

Size	Pneumatic	Hydraulic
PN16	Seat: 7 bar	Shell: 24 bar Seat: 17.6 bar
CL300	Seat: 7 bar	Shell: 40 bar

Material:

NO.	Component	Material
1	Cover	Ductile Iron+Epoxy Coated
2	Cover Bearing	Stainless Steel
3	Shaft/Stem	Stainless Steel
4	Stud	Zinc Plated Steel/Stainless Steel
5	Cover Nut	Zinc Plated Steel/Stainless Steel
6	Washer	Zinc Plated Steel/Stainless Steel
7	Diaphragm	Buna- N (Nitrile) +Nylon
8	Spring	Stainless Steel
9	Disc Retainer	Ductile Iron+Epoxy Coated
10	Seat Disc	Buna-N(Nitrile)
11	Body	Ductile Iron+Epoxy Coated
12	Plug	Brass/Zinc Plated Steel
13	Stem Nut	Stainless Steel
14	LockWasher	Stainless Steel
15	Spring Washer	Stainless Steel
16	Diaphragm Washer	Ductile Iron+Epoxy Coated
17	Spacer Washer Fiber	Fiber
18	Disc Guide	Stainless Steel
19	Seat O-Ring	Buna-N(Nitrile)
20	Seat Ring	Stainless Steel



Specification

- Test Standard: ISO/DIS 5208:2007
- Design Standard: AWWA C530
- Connection Standard: Thread & Flanged is available
W-M115-74-BSPT CL 300 BSPT to ISO 7-1
W-M115-74-Flange to PN16 to BS EN 1092-2
- Pressure Reducing Range: 30Psi~300Psi
(0.206Mpa~2.06Mpa)
- Low Flow By-Pass range: 20Psi-175Psi
(0.137Mpa~1.20Mpa)
- Standard Pressure Setting: 70Psi (0.482MPa)
- Medium: water

Typical Application

- Water plant and water source project
- Environmental protection
- Municipal facilities
- Electric power and utilities
- Construction industry

Mustang Series Main valve

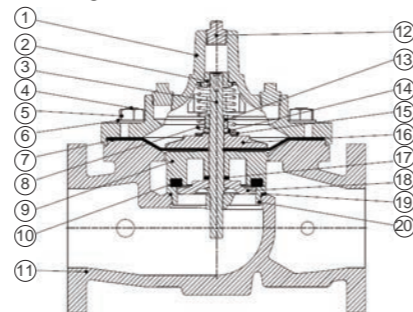

EU Series Main valve

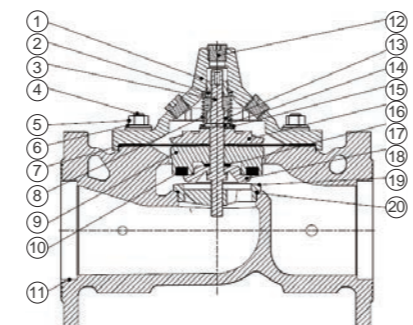

W-M115-74-EN-202212

Installation Dimensions

Connection Dimension: PN16 to BS EN 1092-2

Size DN	Dimensions(mm)				Flange Dimensions(mm)				Weight (Kg)
	L	H	H1	B	C	n-ØD	E	T	
32 BSPT	184	262	221	470	/	/	/	/	20
40 BSPT	184	262	221	470	/	/	/	/	22
50 BSPT	230	333	250	490	/	/	/	/	23
50	230	333	250	490	125	4-φ 19	165	19	19.8
65	290	343	250	495	145	4-φ 19	185	19	20.1
80	310	355	255	505	160	8-φ 19	200	19	21
100	350	397	295	545	180	8-φ 19	220	19	37.5
150	480	508	365	600	240	8-φ 23	285	19	73
200	600	600	433	650	295	12-φ 23	340	20	141

*Please contact the local salesman if the size ≥ DN250 is needed.

Flow Rates

Size (DN)	32	40	50	65	80	100	150	200
Maximum Continuous (GPM)	95	130	210	300	485	800	1850	3100
Maximum Intermittent (GPM)	119	161	265	390	590	1000	2300	4000
Minimum Continuous (GPM)	1	1	1	20	30	50	115	200
CV Factor GPM (Globe)	25	30	45	75	100	175	490	770

Characteristic Curves

Full Port Series

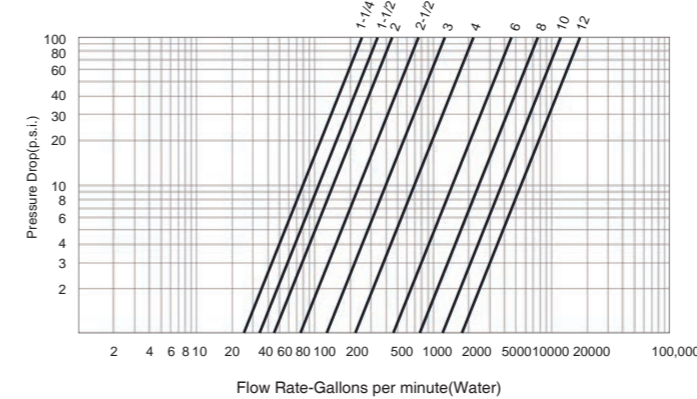

Reduce Port Series

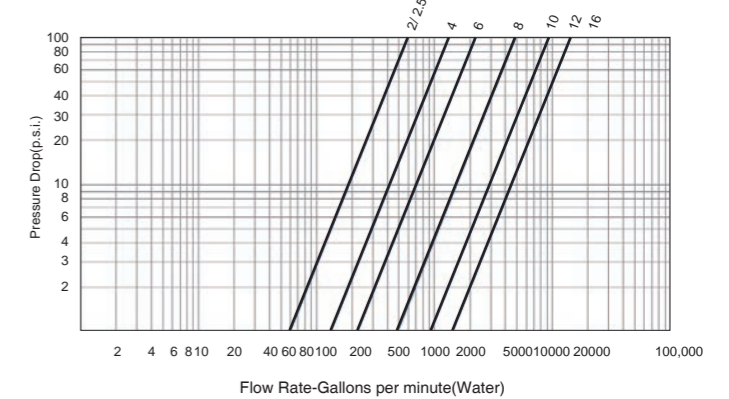

Cavitation Chart

After selecting the valve size, locate inlet and outlet pressure on this chart. If the intersection point falls in the shaded area, cavitation can occur. Operation of valves continually in the cavitation zone should be avoided. Consult Watts ACV for alternatives.

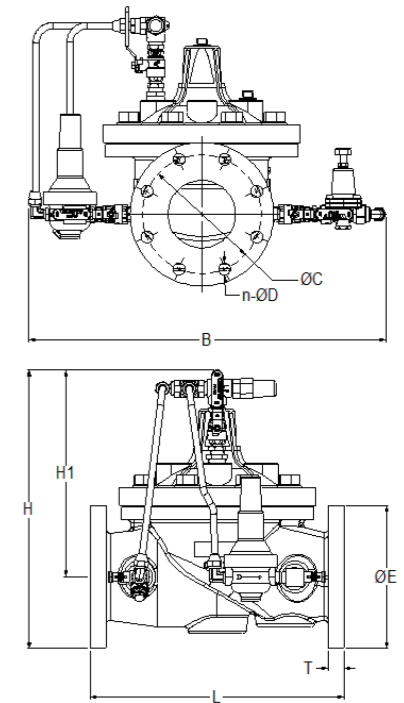
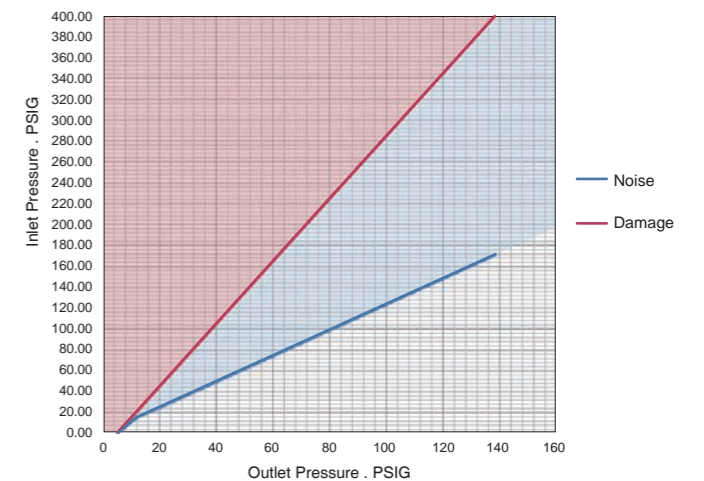



PR 500-EN-202212

Series PR 500

Flanged Automatic Control Valve

Size: DN50-DN250

Reliable and simple, the PR500 is a flanged water pressure reducing valve. It is used for the general supply piping or a secondary circuit when water pressure must be maintained constant.

Features

- Stabilizes automatically the pressure downstream to the set value
- Simple pressure setting by screw nut system on the pilot
- Iron epoxy coated body
- Standard installation in horizontal position (vertical installation with rising fluid: from DN 50 to 150 only)
- Minimum maintenance

Pressure - Temperature

- Operating temperature Maxi: 70 °C
- Permissible operating pressure (PFA) : 16bar

Material

NO.	Component	Material
1	Body	Cast iron 40 interior and exterior epoxy coated
2	Cover	Cast iron 40 interior and exterior epoxy coated
3	Diaphragm	NBR
4	Seat	Stainless steel 316
5	Stem	Stainless steel 303
6	Spring	Stainless steel 302
7	Seals	NBR
8	Flexible tubing	PA11
9	Pilote	Stainless steel
10	Setting screw	Stainless steel

Installation Dimensions

DN	A	B1	B2	C1	C2
50	230	170	85	165	95
65	290	170	85	165	95
80	310	175	85	165	100
100	350	190	120	210	110
125	400	200	150	285	125
150	480	210	150	285	145
200	600	235	200	360	170
250	730	280	255	475	200

Setting

The pressure setting is ultra simple by screw nut system on the pilot valve.
 Turning clockwise = increase the pressure.
 Turning anticlockwise = reduce the pressure.
 Check the value by a pressure gauge.
 Then, tighten the adjusting screw retaining nut.

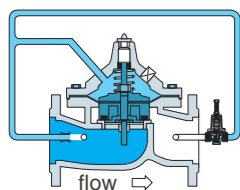

Specification

- Gauge connection: F3/8" from DN50 to DN80
F1/2" from DN100 to DN250
- setting range: see table above
- Connection: Flanges
- Mediums: Water

Approval

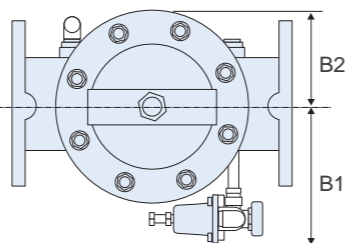
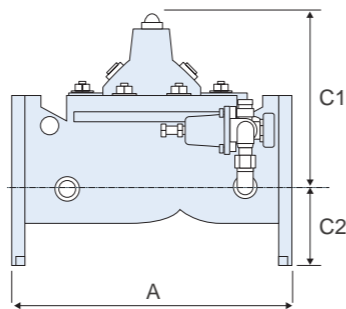
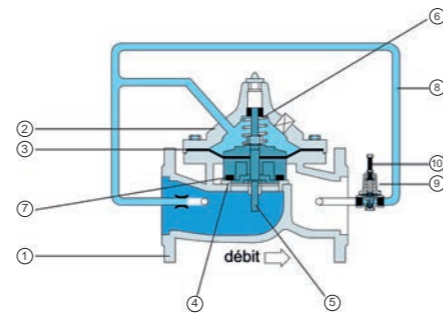

PR 500-EN-202212

Maintenance

The PR500 conception and the quality of its materials to avoid interventions of maintenance for many years. It is however recommended for safe operation, perform the following checks :

1. After approximately two to four months of operation, check the cleanliness of the filter installed upstream of the PR500.
The clogging level gives an indication on the cleanliness of the water and the frequency of cleaning of the strainer
2. If the water hardness is high (TH greater than 25), each year check if the movement of the guide stem valve is free(stem set/mobile valve).
It is recommended to inspect once a year the internal parts of the valve and the control of the pilot circuit.
The parts must be descaled and if necessary replaced.
3. In case of presence of water treatment, make sure that it is not aggressive and that it creates no corrosion phenomena on the valve and its pilot. If necessary, adjust the water treatment and carry out controls, cleaning and/or replacement of damaged parts.
4. After stop or maintenance: check the setting of the pressure reducing valve, and redo it if necessary.
Check that water put in operation was not an opportunity to a sudden influx of sand and other waste.

Cavitation

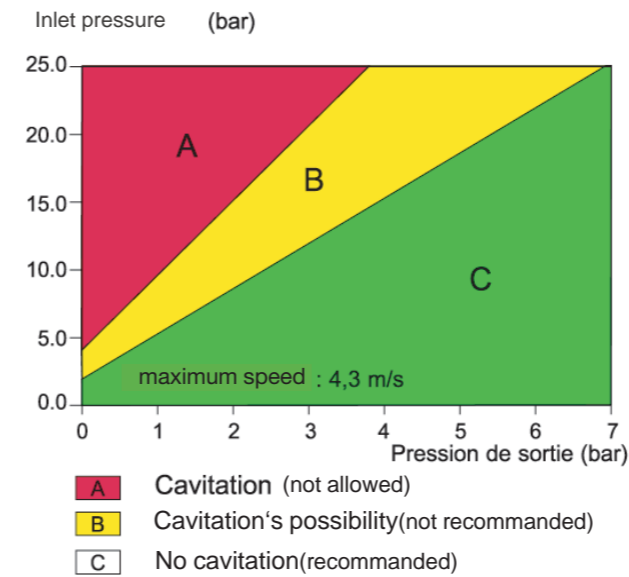

Characteristic Curve

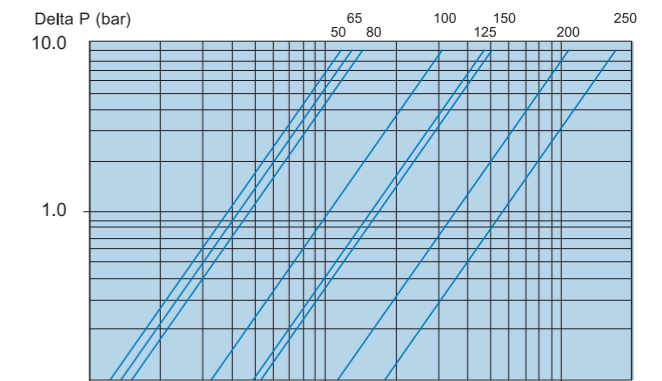



200X-25C-EN-202212

Series W-200X-25C

Pressure Reducing Valve

Size: DN50-DN600

The Watts W-200X Pressure Reducing Valve is designed to make the water in the pipe decreasing automatically from high pressure to stable low pressure, when there is pressure wave in front of the valve or flow change, and the outlet pressure can be adjusted at will within a certain range. It's generally used in building services, water treatment, etc.

Features

- Opening and closing without friction
- Modularization structure
- Reliable sealing performance
- Easy to operate
- Wide application scope

Pressure-Temperature

- Nominal Pressure: PN25
- Pressure Regulating Range: 0.2MPa~1.6MPa
- Temperature Range: 0°C~80°C

Typical Application:

- Water plant and water source project
- Environmental protection
- Municipal facilities
- Electric power and utilities
- Construction industry

Material

Component	Body/Bonnet	Stem/Seat	Diaphragm	Seal ring
Material	Carbon Steel Coated with Epoxy	Stainless Steel	NBR+Nylon	NBR

Installation Dimension

DN	50	65	80	100	125	150	200	250	300	350	400	450	500	600
L	203	216	241	292	330	356	495	622	698	787	914	978	1075	1230
H1	210	215	245	305	365	415	540	560	658	696	735	735	620	685
H	395	405	430	510	560	585	675	730	760	840	910	910	750	850

Connection Dimension: PN25 to BS EN 1092-1

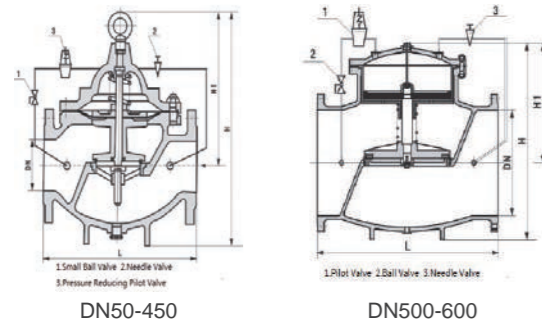

Specification

- Design Standard: JB/T 10674-2006
- Connection Standard: BS EN 1092-1
- Test Standard: BS EN 12266-2:2002
- Medium: water

Cavitation Chart

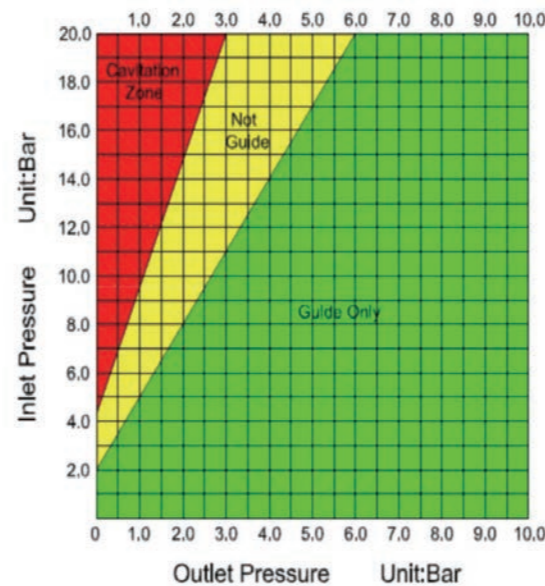

Pressure Drop Chart

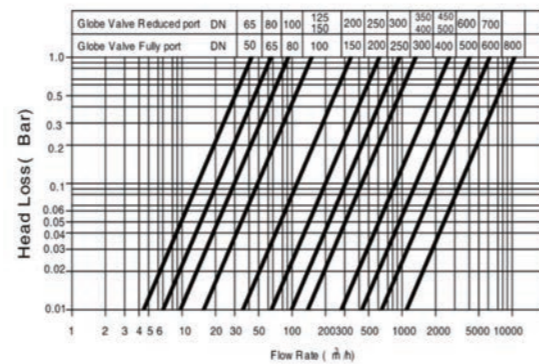

W-M110-10-EN-202212

Series W-M110-10

Ductile Iron Modulating Float Control Valve

Size: Thread DN32-DN50 Flange DN50-DN300

The Watts W-M110-10 Modulating Float Control Valve consists of the main valve of the hydraulic control valve and adjustable floating ball valve. It can adjust the liquid level height, once the adjustment is completed, the valve will always maintain the liquid level height. It's generally used in water tank or reservoir in industrial enterprises and residential buildings.

Features

- Compact structure, reliable sealing
- Simple structure, convenient maintenance
- Control the main valve opening and closing through floating ball valve, making sure that water level inside the water tank keeps given height
- The main valve opening or closing speed can be adjusted by the needle valve

Pressure - Temperature

- Nominal Pressure: PN16/CL300(Thread)
- Temperature Range: 0°C ~ 80°C
- Float Valve Working Pressure: 116Psi (8Bar) WRAS
43.5Psi(3Bar) Normal
- Minimum Different Pressure: 5Psi (0.035MPa)

Test Pressures

Class	Pneumatic	Hydraulic
PN16	Seat: 7 bar	Shell: 24 bar Seat: 17.6 bar
CL300	Seat: 7 bar	Shell: 40 bar

Material

NO.	Component	Material
1	Cover	Ductile Iron+Epoxy Coated
2	Cover Bearing	Stainless Steel
3	Shaft/Sten	Stainless Steel
4	Stud	Zinc Plated Steel/Stainless Steel
5	Cover Nut	Zinc Plated Steel/Stainless Steel
6	Washer	Zinc Plated Steel/Stainless Steel
7	Diaphragm	Buna -N (Nitrile) +Nylon
8	Spring	Stainless Steel
9	Disc Retainer	Ductile Iron+Epoxy Coated
10	Seat Disc	Buna-N (Nitrile)
11	Body	Ductile Iron+Epoxy Coated
12	Plug	Brass/Zinc Plated Steel
13	Stem Nut	Stainless Steel
14	LockWasher	Stainless Steel
15	Spring Washer	Stainless Steel
16	Diaphragm Washer	Ductile Iron+Epoxy Coated
17	Spacer Washer Fiber	Fiber
18	Disc Guide	Stainless Steel
19	Seat O-Ring	Buna-N (Nitrile)
20	Seat Ring	Stainless Steel



Specification

- Design Standard: AWWA C530
- Connection Type: Thread & Flanged is available
BSPT CL 300 BSPT to ISO 7-1
Flange to PN16 to BS EN 1092-2
- Test Standard: ISO/DIS 5208:2007
- Float Diameter: SØ 126 mm
- Certification WRAS 1 1/4" - 2" BSPT (F).
DN50 - DN300 Flanged

Approval



Mustang Series Main valve

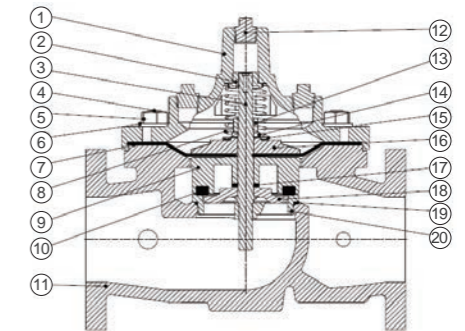

EU Series Main valve

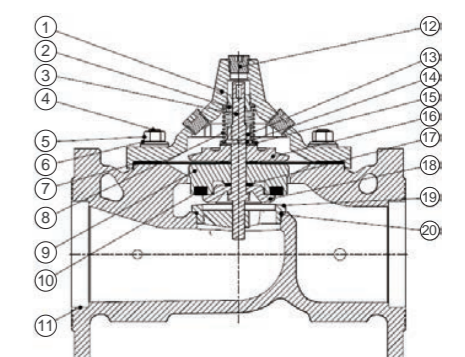

Installation Dimensions

Connection Dimension: PN16 to BS EN 1092-2.

Size DN (mm)	Dimensions(mm)					Flange Dimensions(mm)			Weight (Kg)
	L	H	H1	B	C	n-ØD	E	T	
32 BSPT	184	295	262	210	/	/	/	/	17
40 BSPT	184	295	262	210	/	/	/	/	17
50 BSPT	238	310	262	210	/	/	/	/	17.8
50	230	342	259	225	125	4-Ø19	165	19	18.2
65	290	298	205	225	145	4-Ø19	185	19	18.6
80	310	310	210	225	160	8-Ø19	200	19	19.7
100	350	345	235	310	180	8-Ø19	220	19	35.5
125	400	435	310	240	210	8-Ø19	250	19	57.2
150	480	458	315	270	240	8-Ø23	285	19	70
200	600	535	365	430	295	12-Ø23	340	20	138
250	660	648	445	518	355	12-Ø28	406	30.5	264
300	762	759	518	620	410	12-Ø28	482	31.8	463

*Please contact the local salesman if the size \geq DN300 is needed.

Flow Rates

Size (DN)	32	40	50	65	80	100	150	200	250	300
Maximum Continuous (GPM)	95	130	210	300	485	800	1850	3100	5000	7000
Maximum Intermittent (GPM)	119	161	265	390	590	1000	2300	4000	6250	8725
Minimum Continuous (GPM)	1	1	1	20	30	50	115	200	300	400
CV Factor GPM (Globe)	25	30	45	75	100	175	490	770	1200	1750

Characteristic Curves

Full Port Series

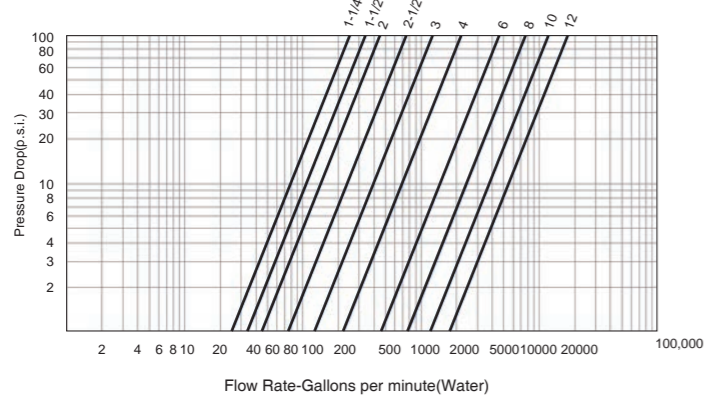

Reduce Port Series

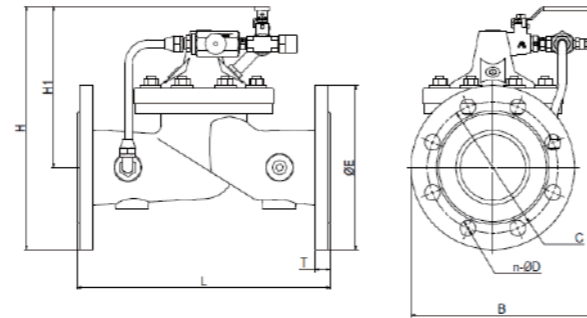
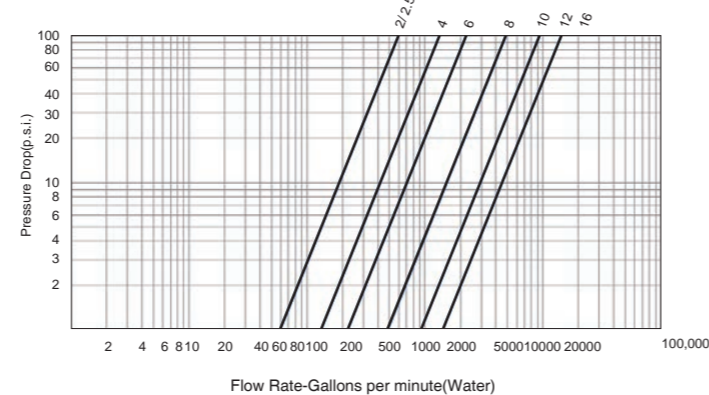

Series W-M110-14

Ductile Iron On/Off Float Control Valve

Size: Thread DN32-DN50 Flange DN50-DN300

The Watts W-M110-14 On/Off Float Control Valve is made up of the main valve of hydraulic control valve and floating ball valve of which stroke can be adjusted. The characteristic of the valve is a large range of liquid level control height. Controlled by high and low points in the floating ball stem, it can reduce the frequency of the main valve opening and closing and prolong the service life.

Features

- Compact structure, reliable sealing
- Simple structure, convenient maintenance
- Control the main valve opening and closing through floating ball valve, making sure the water level inside the water tank keeps setting height
- The main valve opening or closing speed can be adjusted by the needle valve

Pressure - Temperature

- Nominal Pressure: PN16/CL300(Thread)
- Temperature Range: 0°C ~ 80°C
- Minimum Different Pressure: 5Psi(0.035MPa)

Test Pressures

Class	Pneumatic	Hydraulic
PN16	Seat: 7 bar	Shell: 24 bar Seat: 17.6 bar
CL300	Seat: 7 bar	Shell: 40 bar

Material

NO.	Component	Material
1	Cover	Ductile Iron+Epoxy Coated
2	Cover Bearing	Stainless Steel
3	Shaft/Stem	Stainless Steel
4	Stud	Zinc Plated Steel/Stainless Steel
5	Cover Nut	Zinc Plated Steel/Stainless Steel
6	Washer	Zinc Plated Steel/Stainless Steel
7	Diaphragm	Buna- N (Nitrile) +Nylon
8	Spring	Stainless Steel
9	Disc Retainer	Ductile Iron+Epoxy Coated
10	Seat Disc	Buna N (Nitrile)
11	Body	Ductile Iron+Epoxy Coated
12	Plug	Brass/Zinc Plated Steel
13	Stem Nut	Stainless Steel
14	LockWasher	Stainless Steel
15	Spring Washer	Stainless Steel
16	Diaphragm Washer	Ductile Iron+Epoxy Coated
17	Spacer Washer Fiber	Fiber
18	Disc Guide	Stainless Steel
19	Seat O-Ring	Buna-N (Nitrile)
20	Seat Ring	Stainless Steel



Specification

- Design Standard: AWWA C530
- Connection Standard: Thread & Flanged is available
W-M110-14-BSPT CL 300 BSPT to ISO 7-1
W-M110-14-Flange to PN16 to BS EN 1092-2
- Float Ball Diameter: SØ 125mm(Rubber)
- Level Control Height: \leq 465mm

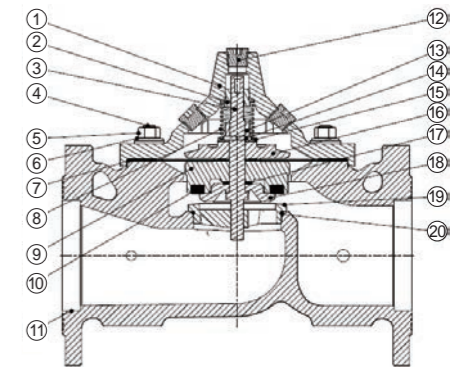



Installation Dimensions

Connection Dimension: PN16 to BS EN 1092-2

Size DN	Dimensions(mm)						Flange Dimensions(mm)					Weight (Kg)
	L	H	H1	B1	B2	D	C	n-ØD	E	T		
32 BSPT	184	313	280	86	168	448	/	/	/	/	18	
40 BSPT	184	313	280	86	168	448	/	/	/	/	18	
50 BSPT	238	328	280	86	168	448	/	/	/	/	18.8	
50	230	363	280	86	168	448	125	4-Ø19	165	19	19.2	
65	290	383	290	86	168	448	145	4-Ø19	185	19	19.6	
80	310	375	275	199	169	448	160	8-Ø19	200	19	20.7	
100	350	401	297	199	193	448	180	8-Ø19	220	19	36.5	
125	400	480	354	209	213	448	210	8-Ø19	250	19	58.2	
150	480	501	358	286	216	448	240	8-Ø23	285	19	71	
200	600	575	404	324	272	448	295	12-Ø23	340	20	139	
250	660	658	455	370	320	448	355	12-Ø28	406	30.5	265	
300	762	740	490	415	375	448	410	12-Ø28	482	31.8	464	

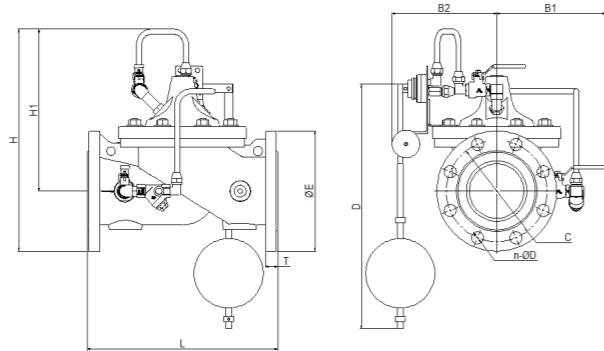

Flow Rates

Size (DN)	32	40	50	65	80	100	150	200	250	300
Maximum Continuous (GPM)	95	130	210	300	485	800	1850	3100	5000	7000
Maximum Intermittent (GPM)	119	161	265	390	590	1000	2300	4000	6250	8725
Minimum Continuous (GPM)	1	1	1	20	30	50	115	200	300	400
CV Factor GPM (Globe)	25	30	45	75	100	175	490	770	1200	1750

Characteristic Curve

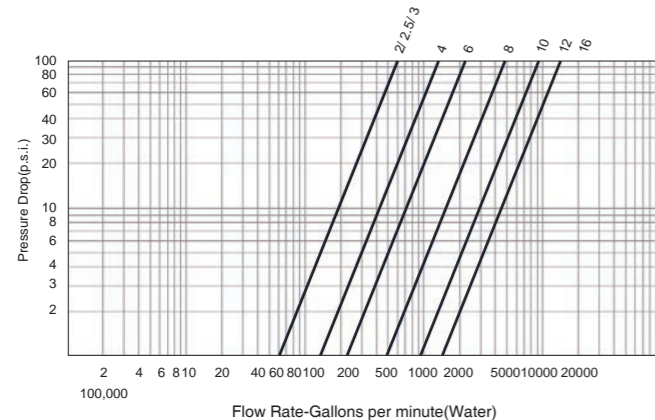

Series W-M116

Ductile Iron Pressure Relief, Sustaining or Backpressure Control Valve

**Size: Thread DN32-DN50
Flange DN50-DN300**

The Watts W-M116 Pressure Relief, Sustaining or Backpressure Control Valve is designed to adjust, set and maintain piping upstream pressure when it's installed in the pipeline. While it is installed in the by-pass line, the function is pressure relief. It's generally used in city water supply, industrial and agricultural water transmission pipeline, etc.

Features

- Stable performance, safe and reliable
- Simple operation, convenient adjusting
- Precise pressure reducing
- Long service life

Test Pressures

Class	Pneumatic	Hydraulic
PN16	Seat: 7 bar	Shell: 24 bar Seat: 17.6 bar
CL150	Seat: 7 bar	Shell: 25.2 bar
CL300	Seat: 7 bar	Shell: 40 bar

Material

NO.	Component	Material
1	Cover	Ductile Iron+Epoxy Coated
2	Cover Bearing	Stainless Steel
3	Shaft/Stem	Stainless Steel
4	Stud	Zinc Plated Steel/Stainless Steel
5	Cover Nut	Zinc Plated Steel/Stainless Steel
6	Washer	Zinc Plated Steel/Stainless Steel
7	Diaphragm	Buna- N(Nitrile) +Nylon
8	Spring	Stainless Steel
9	Disc Retainer	Ductile Iron+Epoxy Coated
10	Seat Disc	Buna-N(Nitrile)
11	Body	Ductile Iron+Epoxy Coated
12	Plug	Brass/Zinc Plated Steel
13	Stem Nut	Stainless Steel
14	LockWasher	Stainless Steel
15	Spring Washer	Stainless Steel
16	Diaphragm Washer	Ductile Iron+Epoxy Coated
17	Spacer Washer Fiber	Fiber
18	Disc Guide	Stainless Steel
19	SeatO-Ring	Buna- N(Nitrile)
20	Seat Ring	Stainless Steel



Specification

- Design Standard: AWWA C530
- Test Standard: ISO/DIS 5208:2007
- Connection Type: Thread & Flanged is available W-M116-BSPT CL 300 BSPT to ISO 7-1 W-M116-Flange to PN16 to BS EN 1092-2 & CL150 to ANSI B16.42 & CL300 to ANSI B16.42
- Medium: water

Pressure - Temperature

- Nominal Pressure: PN16/ CL150/ CL300
- Temperature Range: 0°C-80°C
- Pressure Regulating Range: 20 Psi-200 Psi (0.14MPa~1.4MPa)(Pilot valve)
- Pressure gauge: 0-350Psi
- Standard pressure setting:100 Psi(0.68Mpa)

Mustang Series Main valve

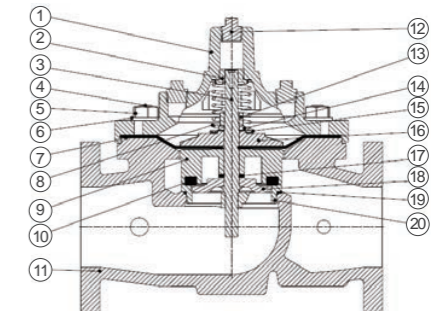

EU Series Main valve

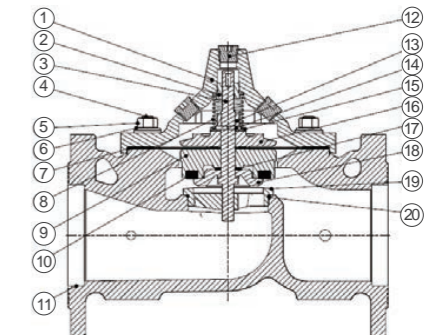



W-M116-EN-202212

Installation Dimensions

Connection Dimension: PN16 to BS EN1092-2

Size DN (mm)	Dimensions(mm)				Flange Dimensions(mm)				Weight (Kg)
	L	H	H1	B	C	n-ØD	E	T	
32 BSPT	184	305	271	265	/	/	/	/	17.5
40 BSPT	184	305	271	265	/	/	/	/	17.5
50 BSPT	238	315	268	275	/	/	/	/	18.2
50	230	272	190	290	125	4-Ø19	165	19	18.9
65	290	290	198	300	145	4-Ø19	185	19	19.5
80	310	290	190	310	160	8-Ø19	200	19	20.4
100	350	395	285	355	180	8-Ø19	220	19	36.7
125	400	395	285	360	210	8-Ø19	250	19	58.9
150	480	430	288	420	240	8-Ø19	285	19	72.3
200	600	540	370	485	295	12-Ø23	340	20	140.4
250	660	655	450	570	355	12-Ø28	406	30.2	265.5
300	762	760	520	680	410	12-Ø28	482	31.8	465.5
400	889	889	600	760	525	16-Ø31	596.9	36.6	618

*Please contact the local salesmen if the size ≥ DN300 is needed.

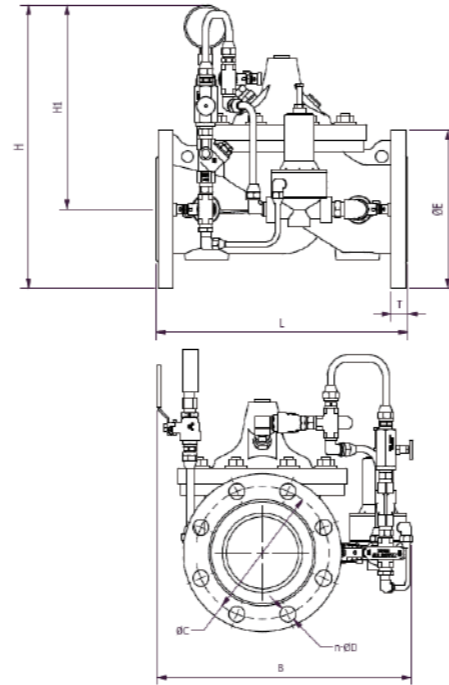

Flow Rates

Size DN (mm)	32	40	50	65	80	100	150	200	250	300
Maximum Continuous (l/s)	95	130	210	300	485	800	1850	3100	5000	7000
Maximum Intermittent (l/s)	119	161	265	390	590	1000	2300	4000	6250	8725
Minimum Continuous (l/s)	1	1	1	20	30	50	115	200	300	400
CV Factor GPM	25	30	45	75	100	175	490	770	1200	1750

Characteristic Curves

Full Port Series

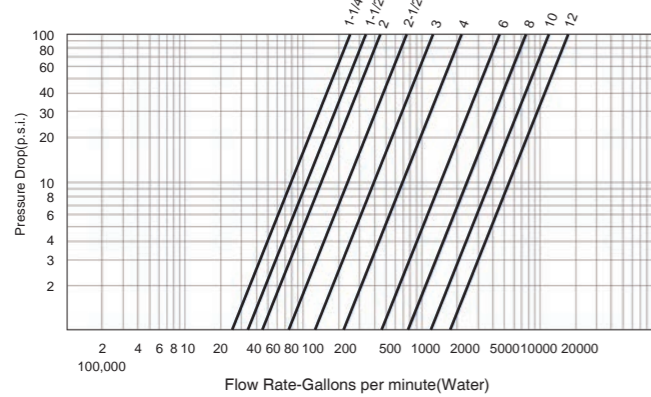

Reduce Port Series

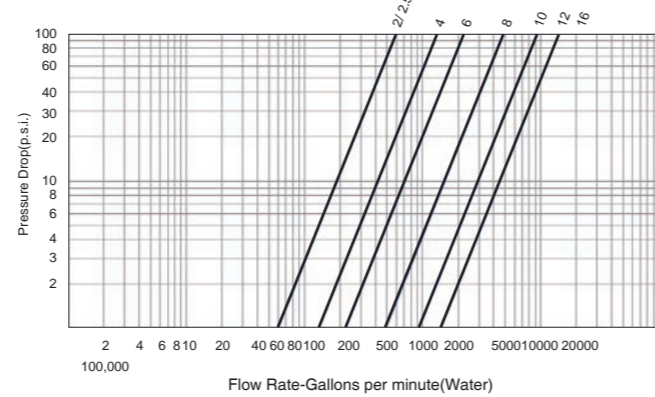

*NOTE: The Cv Factor of a valve is the flow rate in US GPM at 60° F that will cause a 1 psi drop in pressure.

The factors stated are based upon a fully open valve.

Cv factor can be used in the following equations to determine Flow (Q) and Pressure Drop (Δ P):

$$Q \text{ (Flow)} = C_v \sqrt{\Delta P} \quad \Delta P \text{ (Pressure Drop)} = (Q/C_v)^2$$

The above table is a suggested guide-.Inlet pressure, outlet pressure, minimum, normal and maximum flow rates should be considered for specific valve sizing. Contact Watts ACV details.

The above table is a suggested guide-.Inlet pressure, outlet pressure, minimum, normal and maximum flow rates should be considered for specific valve sizing. Contact Watts ACV details.



W-500X-25C-EN-202212

Series W-500X-25C

Pressure Relief, Sustaining or Backpressure Control Valve

Size: DN50-DN400

The Watts W-500X Pressure Relief, Sustaining or Backpressure Control Valve is designed to control the pressure of pipeline system, eliminate the excess pressure of pipe, and keep the pressure of system on the preset pressure point, ensuring the safe operation of the pipeline system. It's generally used in building services, water treatment, etc

Features

- Opening and closing without friction
- Modularization structure
- Reliable sealing performance
- Easy to operate
- Wide application scope

Pressure - Temperature

- Nominal Pressure: PN25
- Temperature Range: 0°C~80°C
- Pressure Regulating Range: 0.2MPa~1.7MPa

Material

Component	Material
Body	Carbon Steel Coated with Epoxy
Bonnet	Carbon Steel Coated with Epoxy
Pilot Valve	Stainless Steel
Connecting Pipe	Stainless Steel

Typical Application

- Water plant and water source project
- Environmental protection
- Municipal facilities
- Electric power and utilities
- Construction industry

Installation Dimensions

Connection Dimension: GB/T 9113

DN	50	65	80	100	125	150	200	250	300	350	400
L	203	216	241	292	330	356	495	622	698	787	914
H1	516	520	537	596	653	709	805	855	953	990	1030
H	610	625	642	750	808	864	1135	1185	1325	1385	1445



Specification

- Design Standard: JB/T 10674-2006
- Test Standard: GB/T 13927-2008
- Working Medium: Water

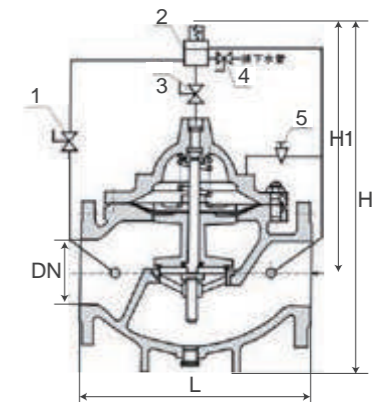

1.Small Ball Valve 2.Pilot Valve 3.Small Ball Valve 4.Small Ball Valve 5.Needle Valve



W-M113-12 / 6-EN-202212

Series W-M113-12/6

Ductile Iron Solenoid On-Off Control Valve

**Size: Thread DN32-DN50
Flange DN50-DN300**

The Watts W-M113 Solenoid On-Off Control Valve can remotely control the switch of valve and truncate the flow of medium in the pipeline. It's generally used in city water supply, industrial and agricultural water transmission pipeline, etc.

Features

- Stable performance, safe and reliable
- Simple operation, convenient maintenance
- Long service life
- Remote electric control or on-site manual control

Test Pressures

Class	Pneumatic	Hydraulic
PN16	Seat: 7 bar	Shell: 24 bar Seat: 17.6 bar
CL150	Seat: 7 bar	Shell: 25.2 bar
CL300	Seat: 7 bar	Shell: 40 bar

Material

NO.	Component	Material
1	Cover	Ductile Iron+Epoxy Coated
2	Cover Bearing	Stainless Steel
3	Shaft/Stem	Stainless Steel
4	Stud	Zinc Plated Steel/Stainless Steel
5	Cover Nut	Zinc Plated Steel/Stainless Steel
6	Washer	Zinc Plated Steel/Stainless Steel
7	Diaphragm	Buna-N(Nitrile) +Nylon
8	Spring	Stainless Steel
9	Disc Retainer	Ductile Iron+Epoxy Coated
10	Seat Disc	Buna-N(Nitrile)
11	Body	Ductile Iron+Epoxy Coated
12	Plug	Brass/Zinc Plated Steel
13	Stem Nut	Stainless Steel
14	LockWasher	Stainless Steel
15	Spring Washer	Stainless Steel
16	Diaphragm Washer	Ductile Iron+Epoxy Coated
17	Spacer Washer Fiber	Fiber
18	Disc Guide	Stainless Steel
19	Seat O-Ring	Buna-N(Nitrile)
20	Seat Ring	Stainless Steel



Specification

- Design Standard: AWWA C530
- Test Standard: ISO/DIS 5208:2007
- Control Voltage: Standard Voltage AC220 50/60HZ
Optional Voltage AC 240V 60HZ, AC24V 60HZ
- Connection Type:
Thread & Flanged is available
W-M113-12-BSPT CL 300 BSPT to ISO 7-1
W-M113-12/6-Flange to PN16 to BS EN 1092-2 & CL150 to ANSI B16.42
- Working Status: Normally open/closed
- Medium: water

Pressure - Temperature

- Nominal Pressure: PN16/CL150/ CL300
- Temperature Range: 0°C-80°C
- Minimum Different Pressure: 5PSI (0.03MPa)

Mustang Series Main valve

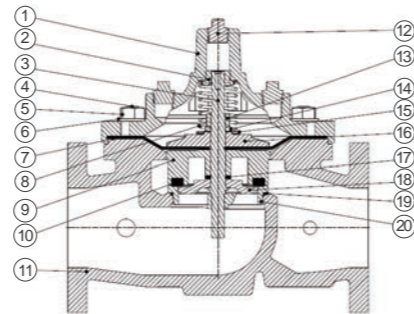

EU Series Main valve

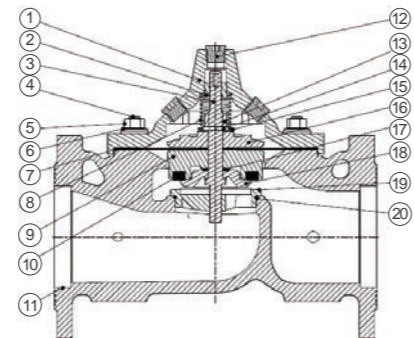

W-M113-12 / 6-EN-202212

Installation Dimensions

Connection Dimension: PN16 to BS EN1092-2.

Type	Size DN (mm)	Dimensions(mm)				Flange Dimensions(mm)				Weight (Kg)
		L	H	H1	B	ØC	n-ØD	E	T	
W-M113-12	32 BSPT	184	305	271	170	/	/	/	/	17.2
	40 BSPT	184	305	271	170	/	/	/	/	17.2
	50 BSPT	238	315	268	170	/	/	/	/	18.0
	50	230	310	228	170	125	4-Ø19	165	19	18.3
	65	290	340	250	185	145	4-Ø19	185	19	18.9
	80	310	345	245	200	160	8-Ø19	200	19	19.8
W-M113-6	100	350	360	250	320	180	8-Ø19	220	19	36.2
	125	400	410	285	380	210	8-Ø19	250	19	58.3
	150	480	505	360	420	240	8-Ø23	285	19	71.5
	200	600	508	410	508	295	12-Ø23	340	20	139
	250	660	650	450	550	355	12-Ø28	406	30.5	264.5
	300	762	755	520	655	410	12-Ø28	482	31.8	464.5

*Please contact the local salesman if the size ≥DN300 is needed.

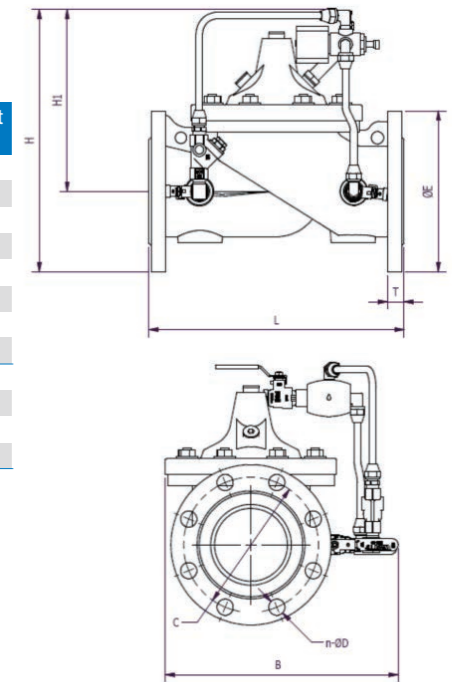

Flow Rates

Size DN (mm)	32	40	50	65	80	100	150	200	250	300
Maximum Continuous (GPM)	95	130	210	300	485	800	1850	3100	5000	7000
Maximum Intermittent (GPM)	119	161	265	390	590	1000	2300	4000	6250	8725
Minimum Continuous (GPM)	1	1	1	20	30	50	115	200	300	400
CV Factor GPM (Globe)	25	30	45	75	100	175	490	770	1200	1750

Characteristic Curves

Full Port Series

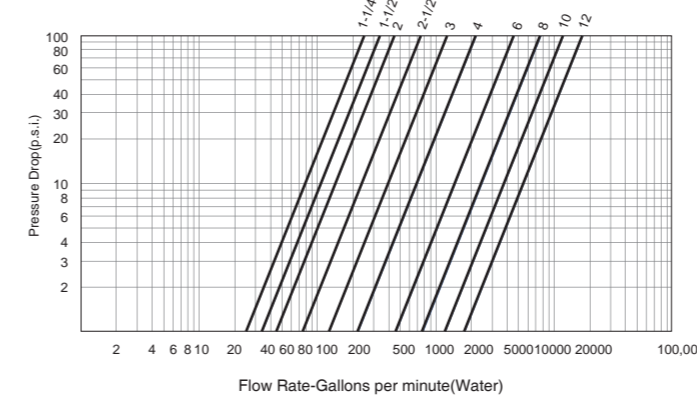

Reduce Port Series

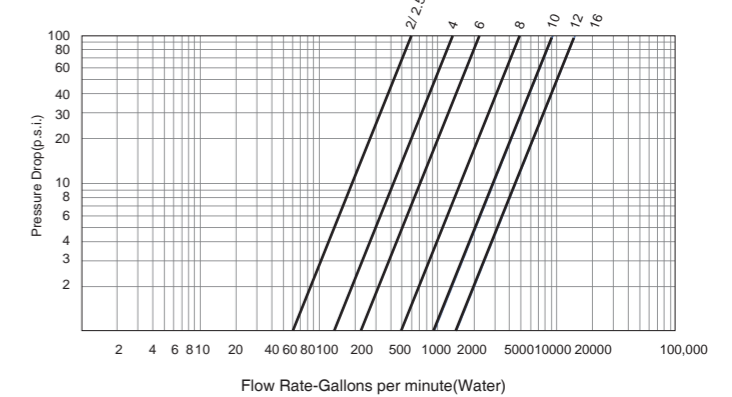

*NOTE: The Cv Factor of a valve is the flow rate in US GPM at 60° F that will cause a 1 psi drop in pressure.

The factors stated are based upon a fully open valve.

Cv factor can be used in the following equations to determine Flow (Q) and Pressure Drop (Δ P):

$$Q (\text{Flow}) = C_v \sqrt{\Delta P} \quad \Delta P (\text{Pressure Drop}) = (Q/C_v)^2$$

The above table is a suggested guide-. Inlet pressure, outlet pressure, minimum, normal and maximum flow rates should be considered for specific valve sizing. Contact Watts ACV details.



LF007-EN-201907

Series LF007

Double Check Valve Assemblies

Size: DN15-DN50 (Thread), DN65-DN80 (Flanged)

Series LF007 Double Check Valve Assemblies shall be installed at referenced cross-connections to prevent the backflow of polluted water into the potable water supply. Only those cross-connections identified by local inspection authorities as non-health hazard shall be allowed the use of an approved double check valve assembly. The LF007 features Lead-Free* construction to comply with Lead-Free* installation requirements. Check with the local authority having jurisdiction regarding vertical orientation, frequency of testing or other installation requirements.

Features

- Lead-Free* cast copper silicon alloy body construction
- Top-mounted Lead-Free* ball valve test cocks
- Modular construction and compact design with the low-pressure drop
- Replaceable seats and seat discs
- Ease of maintenance — only one cover, no special tools required for servicing

Pressure-Temperature

- Nominal Pressure: 175 psi (Thread)
PN12 (Flanged)
- Temperature Range: 0.5°C-43°C continuous (Thread)
60°C intermittent (Flanged)

Test Pressure

Size	Hydraulic
DN15-DN50	175 psi
DN65-DN80	350 psi

Installation Dimensions

Size: DN15 - DN50

MODEL	SIZE (DN)	DIMENSIONS										WEIGHT									
		A		B		C		D		F			G		R		T				
		in.	mm	in.	mm	in.	mm	in.	mm	in.	mm	in.	mm	in.	mm	in.	mm	in.	mm	lbs.	kgs.
LF007QT	1/2	15	10	254	4 5/8	117	2 1/16	62	-	-	5	127	3 3/8	85	2 5/16	59	2 1/16	52	4.5	2	
LF007M3QT	3/4	20	11 1/8	282	4	102	3 1/8	79	-	-	6 3/16	157	3 7/16	87	2 1/8	54	1 5/16	33	5	2.3	
LF007M1QT	1	25	13 3/4	337	5 1/8	130	4	102	-	-	7 1/2	191	3 3/8	85	1 11/16	43	1 11/16	43	12	5.4	
LF007M2QT	1 1/4	32	16 3/8	416	5	127	3 9/16	84	-	-	9 1/2	241	5	127	3	76	2	50	15	6.8	
LF007M2QT	1 1/2	40	16 3/4	425	4 7/8	124	3 1/2	89	-	-	9 3/4	248	5 13/16	148	3 1/8	79	2 11/16	68	15.9	7.2	
LF007M1QT	2	50	19 1/2	495	6 1/4	159	4	102	-	-	13 3/8	340	6 1/8	156	3 7/16	87	2 11/16	68	25.7	11.7	
LF007QT-S	1/2	15	13	330	6	152	2 7/16	62	3	76	5	127	3 3/8	85	2 5/16	59	2 1/16	52	5.5	2.5	
LF007M3QT-S	3/4	20	14 1/2	368	6 1/8	156	3 1/8	79	3	76	6 3/16	157	3 7/16	87	2 1/8	54	1 5/16	33	6.7	3.1	
LF007M1QT-S	1	25	17 15/16	157	7 3/4	197	4	102	3 1/4	83	7 1/2	191	3 3/8	85	1 11/16	43	1 11/16	43	14	6.4	
LF007M2QT-S	1 1/4	32	21 1/2	546	7 1/16	179	3 9/16	84	3 1/2	83	9 1/2	241	5	127	3	76	2	50	19	8.6	
LF007M2QT-S	1 1/2	40	21 3/4	552	7 1/16	179	3 1/2	89	3 3/4	95	9 3/4	248	5 13/16	148	3 1/8	79	2 11/16	68	19.6	8.9	
LF007M1QT-S	2	50	25 3/4	654	8 3/4	222	4	102	4	102	13 3/8	340	6 1/8	156	3 7/16	87	2 11/16	68	33.5	15.2	

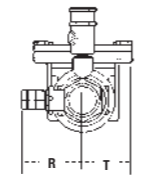
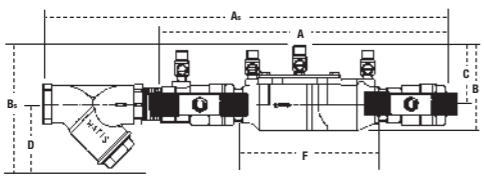

Specification

- Design Standard: ASSE 1015, AWWA C510
- Connection Standard: Threaded to ANSI B1.20.1
Flanged to ASME B16.34
- Available with tee handles, sizes 15 to 25mm
- Available with different assemblies – check Models Chart

Approvals



Models

Sizes:
1/2"-2" (15-50mm)
Suffix:
S-copper silicon alloy strainer
LF-without shutoff valves
W/Press**-press inlet X press outlet (1/2"-2" only)
Prefix:
U-Union connections
2 1/2"-3" (65-80mm)
Suffix:
NRS-non-rising stem resilient seated gate valves
OSY-UL/FM outside stem and yoke resilient seated gate valves
LF-without shutoff valves
QT-FDA-FDA epoxy coated quarter-turn ball valves
** Viega ProPress® connections are optional factory-installed fitting on each end of the approved/certified assembly.



LF007-EN-201907

Sizes: DN65-DN 80

MODEL	SIZE (DN)	DIMENSIONS						WEIGHT			
		A		B		E, E1			R		
		mm	in.	mm	in.	mm	in.	mm	in.	mm	kgs.
LF007QT-FDA	65	33 1/8	841	6 3/8	162	9 1/16	230	8 3/4	222	70	
LF007-NRS	65	33 1/8	841	9 3/8	238	9 1/16	230	8 3/4	222	70	
LF007-OSY	65	33 1/8	841	16 3/8	416	9 1/16	230	8 3/4	222	72	
LF007-QT-FDA	80	34 1/4	870	6 3/8	162	9 1/16	230	8 3/4	222	70	
LF007-NRS	80	34 1/4	870	10 1/4	260	9 1/16	230	8 3/4	222	84	
LF007-OSY	80	34 1/4	870	18 7/8	479	9 1/16	230	8 3/4	222	84	

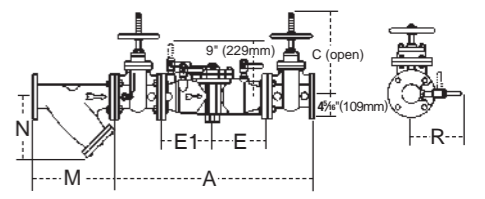

Strainer Dimension

SIZE	M		N		WEIGHT	
	in.	mm	in.	mm	lbs.	kgs.
2 1/2	65	10	254	6 1/2	28	13
3	80	10 1/8	267	7	178	34
					15	

Characteristic Curves

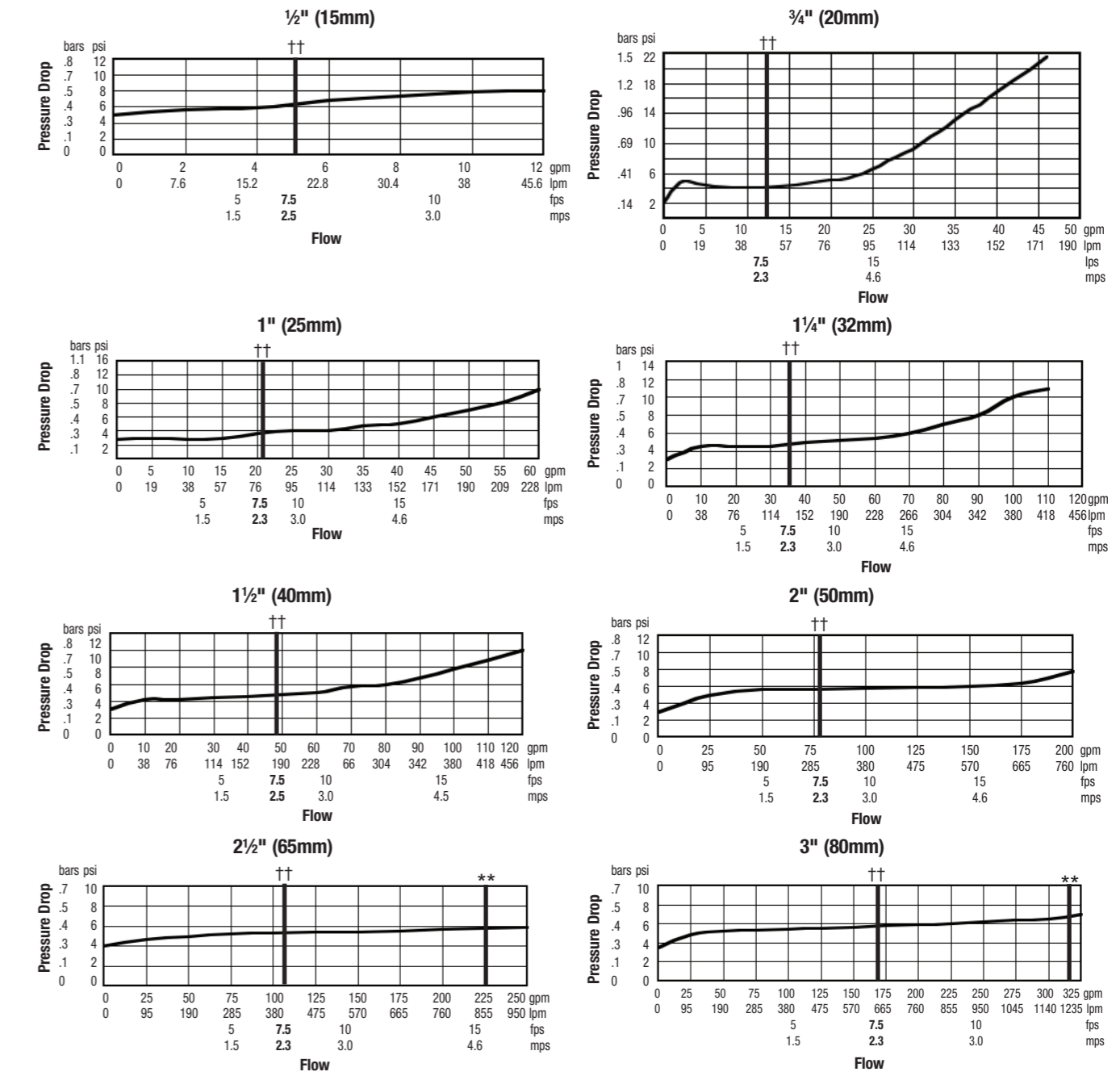



LF709-EN-201907

Series LF709

Double Check Valve Assemblies

Size: DN65-DN250

Series LF709 Double Check Valve Assemblies shall be installed at referenced non-health hazard cross-connections to prevent the backflow of polluted water into the potable water supply.

Features

- Replaceable stainless steel seats
- Maximum flow at low pressure drop
- Design simplicity for easy maintenance
- No special tools required for servicing
- Captured spring assemblies for safety
- Approved for vertical flow up installation

Pressure-Temperature

- Nominal Pressure: PN12
- Temperature Range: 5°C-43°C continuous, 60°C intermittent

Models

NRS	non-rising stem resilient seated gate valves
OSY	UL/FM outside stem and yoke resilient seated gate valves
S-FDA	FDA epoxy coated strainer
QT-FDA	FDA epoxy coated ball valve shutoffs
LF	without shutoff valves



Specification

- Design Standard: IAMPO PA31, AWWA C510-92
- Connection Standard: Flanged to ASME B16.34
- Pressure Test: Hydraulic 350 psi
- Approved by the Foundation for Cross-Connection Control and Hydraulic Research at the University of Southern California. Sizes 4"-10" approved horizontal and vertical "flow up". Size 2 1/2" and 3" approved horizontal only. Factory Mutual approved 4"-10" vertical "flow up" with OSY gate valves only

Approvals



Installation Dimensions

SIZE in.	DIMENSIONS													WEIGHT		STRAINER
	A	C (OSY)	C (NRS)	D	L	U††	M	N	N1†	R	R*	T	NRS	OSY	QT	Weight
2 1/2	39 3/8	16 3/8	9 3/8	3 1/2	24 1/8	11	10	6 1/2	4	16	3	167	170	154	28	
3	40 3/8	18 7/8	10 1/4	3 3/4	24 1/8	14	10 1/8	7	10	5	16	3	167	170	162	34
4	52 3/8	22 3/4	12 3/16	4 1/2	34 1/8	14	12 1/8	8 1/4	12	6	19 3/4	6	368	383	275	60
6	62 7/8	30 1/8	16	5 1/2	41 1/8	16	18 1/2	13 1/2	20	11	26	7 1/2	627	707	611	122
8	75	37 3/4	19 15/16	6 1/2	52	21	21 5/8	15 1/2	22 3/4	11 1/4	11 1/4	9	1201	1307	1419	247
10	90	45 3/4	23 13/16	8	64	25	26	18 1/2	28	12 1/2	12 1/2	10 1/4	2003	2073	2466	370

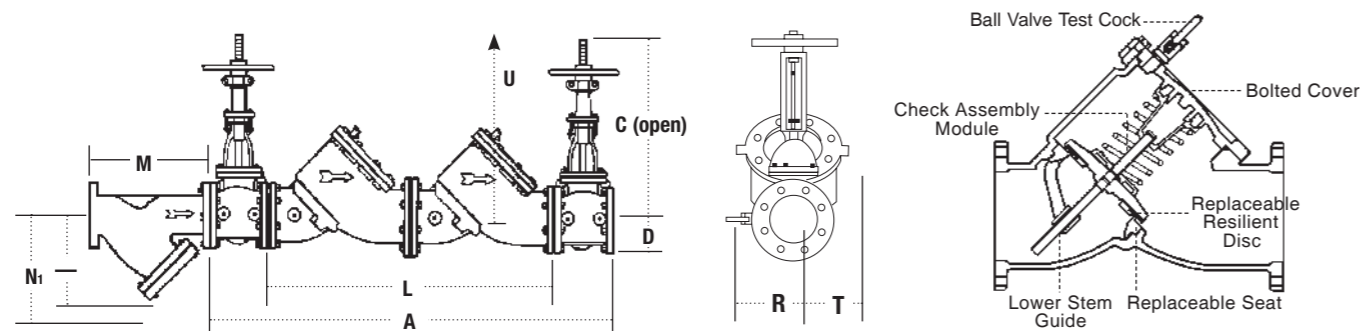

LF709-EN-201907

Characteristic Curve

‡Typical maximum system flow rate (7.5 feet/sec.)
**UL rated flow

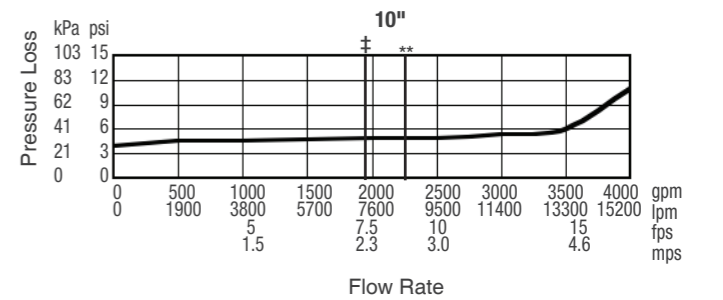
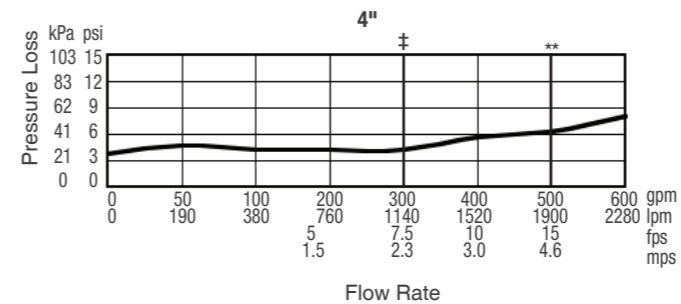
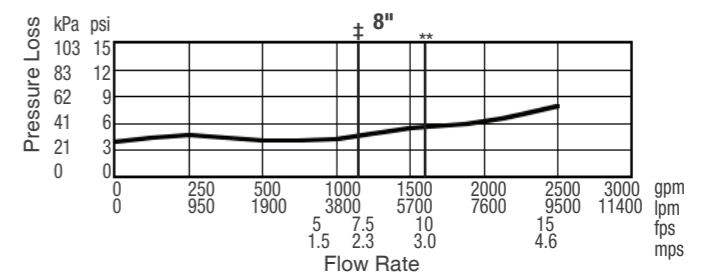
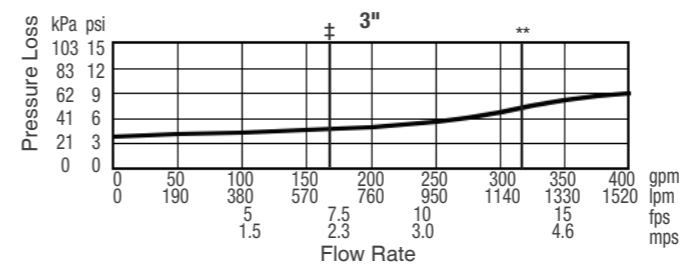
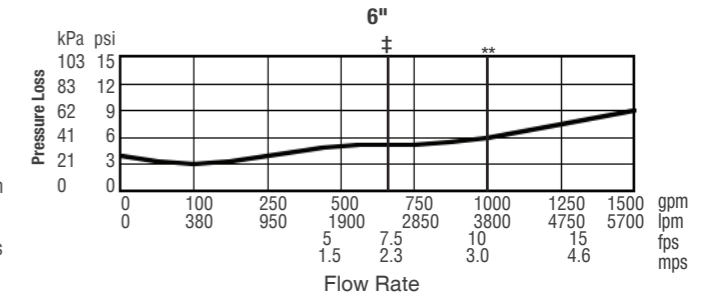
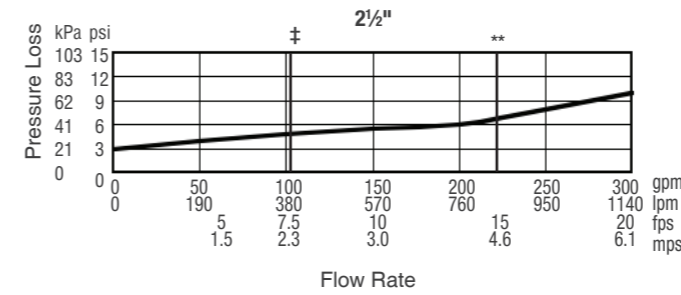



774-EN-202212

Series 774

Double Check Valve Assemblies

Size: DN65-DN300

Series 774 Double Check Valve Assemblies are designed to prevent the reverse flow of polluted water from entering into the potable water system.

Features

- Torsion spring check valve provides low head loss
- Short lay length is ideally suited for retrofit installations
- The stainless steel body is half the weight of competitive designs reducing installation and shipping cost
- Stainless steel construction provides long term corrosion protection and maximum strength
- Single top access cover with two-bolt grooved style coupling for ease of maintenance
- Thermoplastic and stainless steel check valves for trouble-free operation
- No special tools required for servicing
- Compact construction allows for smaller vaults and enclosures
- May be installed in horizontal or vertical "flow up" position

Material

Component	Material
All internal metal parts	300 Series stainless steel
Main valve body	300 Series stainless steel
Check assembly	Noryl®

Installation Dimensions

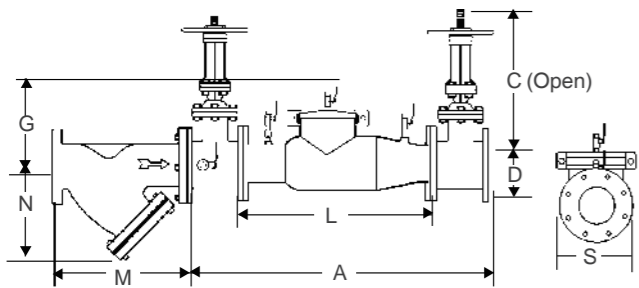

Specification

- Design Standard: CSA B64.5, AWWA C510-92
- Connection Standard: Flanged to AWWA class D

Pressure-Temperature

- Nominal Pressure: 175PSI (12.1ba)
- Temperature Range: 5 °C ~43°C (continuous)

Test Pressure

Hydraulic
350psi

Approvals

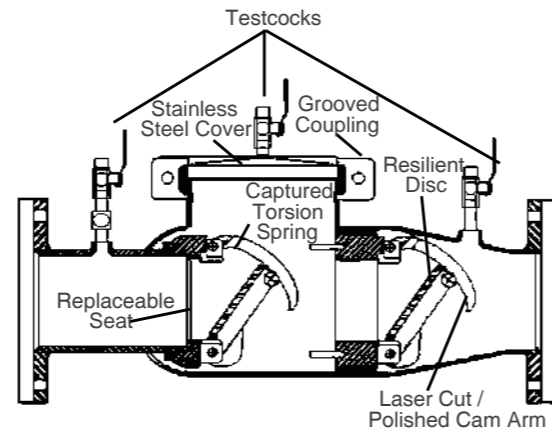

Size	A		C (open)				D		G		L		M		N		S		Weight				
	in.	mm	OSY		NRS		in.	mm	in.	mm	in.	mm	in.	mm	Screen Removal		in.	mm	lbs.	kgs	lbs.	kgs	
1 1/2	65	37	940	16 3/8	416	9 3/8	238	3 1/2	89	10	254	22	559	10	254	6 1/2	165	7	178	140	64	53	24
3	80	38	965	18 7/8	479	10 1/4	260	3 3/4	95	15	381	22	559	10 1/8	257	7	178	7 1/2	191	215	98	55	25
4	100	40	1016	22 3/4	578	12 3/16	310	4 1/2	114	10	254	22	559	12 1/8	308	8 1/4	210	9	229	225	102	58	26
6	150	48 1/2	1232	30 1/8	765	16	406	5 1/2	140	15	381	27 1/2	699	18 1/2	470	13 1/2	343	11	279	375	170	105	48
8	200	52 1/2	1334	37 3/4	959	19 15/16	506	6 3/4	171	15	381	29 1/2	749	21 5/8	549	15 1/2	394	13 1/2	343	561	254	169	77
10	250	55 1/2	1410	45 3/4	1162	23 13/16	605	8	200	15	381	29 1/2	749	26	660	18 1/2	470	16	406	763	346	179	81
12	300	57 1/2	1461	53 1/8	1349	26 3/4	679	9 1/2	241	15	381	29 1/2	749	29 7/8	759	21 3/4	552	19	483	1033	469	209	95



774-EN-202212

Characteristic Curve

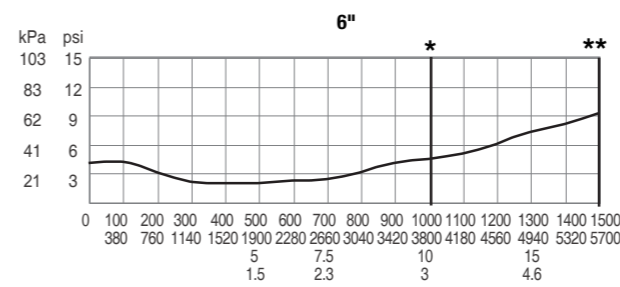
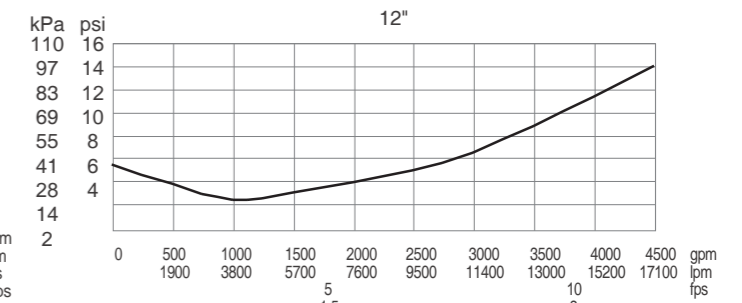
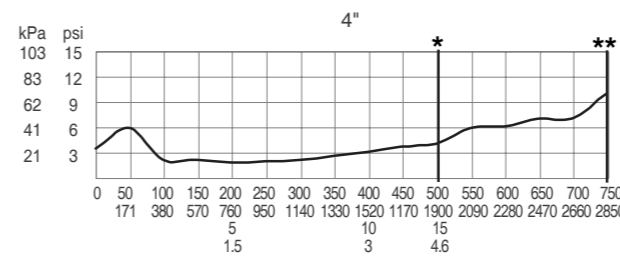
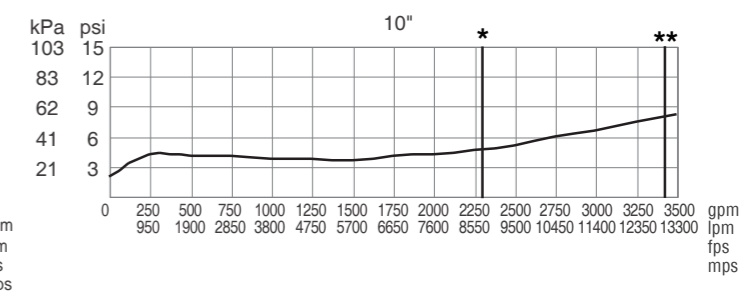
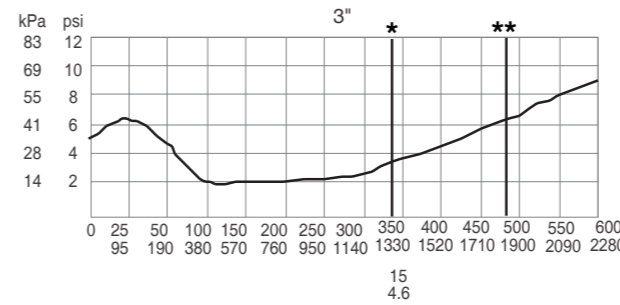
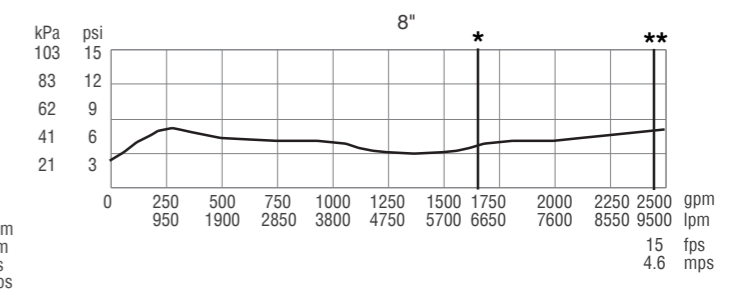
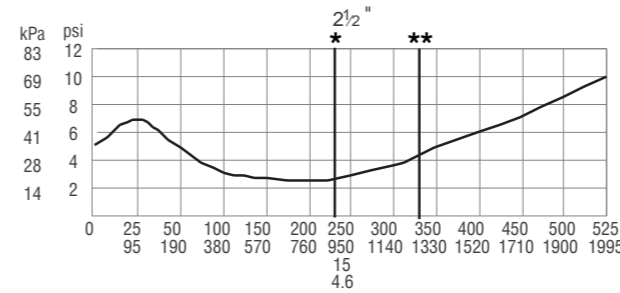



LF009-EN-202212

Series LF009 and LF009-FS

Reduced Pressure Zone Assemblies

Size: 1/4" – 3"

Series LF009 and LF009-FS Reduced Pressure Zone Assemblies are designed to protect potable water supplies in accordance with national plumbing codes and water authority requirements. These series are used in a variety of installations, including the prevention of health hazard cross-connections in piping systems or for containment at the service line entrance. They are also used in irrigation systems, boiler feed, water lines, and other installations requiring maximum protection. The body construction is fused with ArmorTek™ coating technology to resist corrosion due to microbial induced corrosion (MIC) or exposed metal substrate.* The series also features Lead Free* construction to comply with Lead Free* installation requirements.

Both series feature two in-line, independent check valves, captured springs, and replaceable check seats with an intermediate relief valve. Its compact modular design facilitates easy maintenance and assembly access. Sizes 1/4" to 1" shutoffs have tee handles. Series LF009-FS assemblies of sizes 1/2" to 2" include an integrated flood sensor to detect excessive water discharges from the relief valve. When activated through an add-on sensor connection kit, the flood sensor relays a signal that triggers notification to qualified service personnel who can take corrective action, thus avoiding the possibility of ruinous flooding and costly damage. The add-on sensor connection kit is available for both building management systems, or BMS, and cellular communication. (For more information, refer to Installation, Maintenance, and Repair Manual, Series 009-FS and LF009-FS.)

Features

- Single access cover and modular check construction for ease of maintenance
- Top entry to all internals for immediate accessibility
- Captured springs for safe maintenance
- Internal relief valve for reduced installation clearances
- Replaceable seats for economical repair
- ArmorTek™ coating technology to resist internal corrosion†
- Lead Free* cast copper silicon alloy body construction (1/4" – 2")
- Fused epoxy coated cast iron body (2 1/2" – 3")
- Ball valve test cocks — screwdriver slotted (1/4" – 2")
- Large body passages provides low pressure drop
- Compact, space saving design
- No special tools required for servicing
- Integrated sensor for flood detection (1/2" – 2")

Pressure-Temperature

- Sizes 1/4" – 2"
- Suitable for supply pressure up to 175 psi (12.1 bar)
 - Water temperature: 33°F – 180°F (0.5° – 82°C)
- Sizes 2 1/2" – 3"
- Suitable for supply pressures up to 175 psi (12.1 bar)
 - Water temperature: 110°F (43°C) continuous; 140°F (60°C) intermittent

Standards

- USC
- ASSE No. 1013
- AWWA C511
- CSA B64.4
- IAPMO File No. 1563

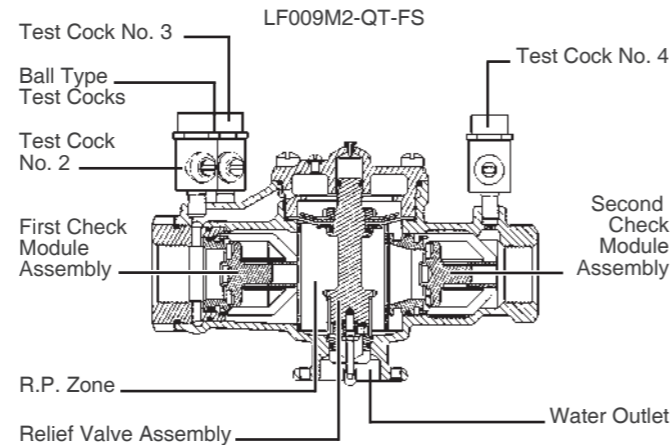
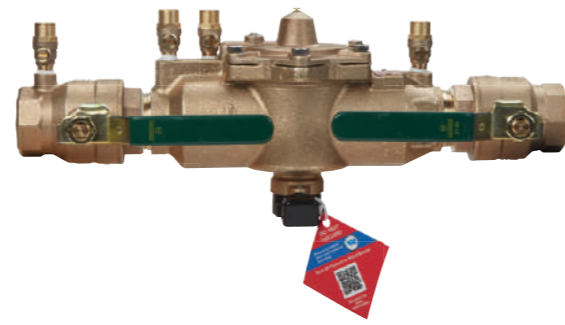

Specification

A Reduced Pressure Zone Assembly shall be installed at each potential health hazard location to prevent backflow due to backsiphonage and/or backpressure. The assembly shall consist of an internal pressure differential relief valve located in a zone between two positive seating check modules with captured springs and silicone seat discs. Seats and seat discs shall be replaceable in both check modules and the relief valve. There shall be no threads or screws in the waterway exposed to line fluids. Service of all internal components shall be through a single access cover secured with stainless steel bolts. Body and shutoffs shall be constructed using Lead Free* cast copper silicon alloy materials. Lead Free* reduced pressure zone assembly shall comply with state codes and standards, where applicable, requiring reduced lead content.

The assembly shall also include two resilient seated isolation valves, four resilient seated test cocks, and an air gap drain fitting. The valve body shall utilize a coating system with built-in electrochemical corrosion inhibitor and microbial inhibitor.† The assembly shall meet the requirements of USC; ASSE Std. 1013; AWWA Std. C511; CSA B64.4. Shall be a Watts Series LF009.

Approvals



- ASSE, AWWA, CSA, IAPMO
- Approved by the Foundation for Cross-Connection Control and Hydraulic Research at the University of Southern California
- Approval models NRS, OSY, PC, QT
- UL Classified
- 2 1/2" – 3" with OSY gate valves
- 3/4" – 2" without shutoff valves (-LF), except LF009M3LF



LF009-EN-202212

Available Models: 1/4" – 2"

- Prefix:
- U – Union connections
- Suffix:
- LF – Without shutoff valves
 - PC – Internal polymer coating
 - Press** – Press inlet x press outlet (1/2" – 2")
 - QT – Quarter-turn ball valves
 - S – Strainer

Available Models: 2 1/2" – 3"

- Suffix:
- LF – Without shutoff valves
 - NRS – Non-rising stem resilient seated gate valves
 - OSY – UL/FM outside stem and yoke resilient seated gate valves
 - S-FDA – FDA – FDA epoxy coated strainer

NOTE: The installation of a drain line is recommended. When installing a drain line, an air gap is necessary. (For more information download ES-AG/EL/TC at watts.com.)

Air Gaps and Elbows

MODEL	DRAIN OUTLET	DIMENSIONS				WEIGHT			
		in.	mm	A in.	B mm	lb	kg		
909AGA	For 909, 009, and 993 sizes 1/4"-1/2" 009, 3/4" 009M2/M3	1/2	13	2 3/8	60	3 3/8	79	0.625	0.28
909AGC	3/4"-1" 009/909, 1"-1 1/2" 009M2	1	25	3 1/4	83	4 1/8	124	1.5	0.68
909AGF	1 1/4"-2" 009M1, 1 1/4"-3" 009/909, 2" 009M2, 4"-6" 993	2	51	4 3/8	111	6 3/8	171	3.25	1.47
909AGK	4"-6" 909, 8"-10" 909M1	3	76	6 3/8	162	9 3/8	244	6.25	2.83
909AGM	8"-10" 909	4	102	7 3/8	187	11 1/4	286	15.5	7.03
909ELA	1/4"-1/2" 009, 3/4" 009M2/M3	-	-	-	-	-	-	-	-
909ELC	3/4"-1" 009/909	-	-	2 3/8	60	2 3/8	60	0.38	0.17
909ELF*	1 1/4"-2" 009M1, 1 1/4"-2" 009/909, 2" 009M2, 4"-6" 993	-	-	3 3/8	92	3 3/8	92	2	0.91
909ELH*	2 1/2"-3" 009/909	-	-	-	-	-	-	-	-
Vertical									

*Epoxy coated

Installation Dimensions

Size: 1/4" – 3/8"

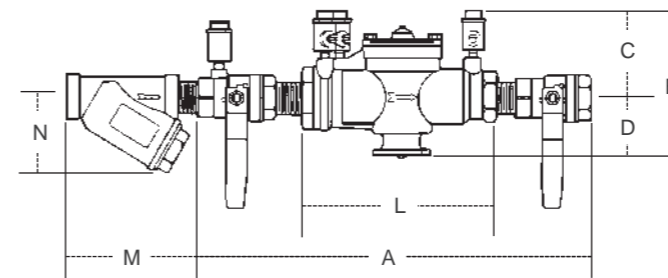

Size: 1/2" – 2"

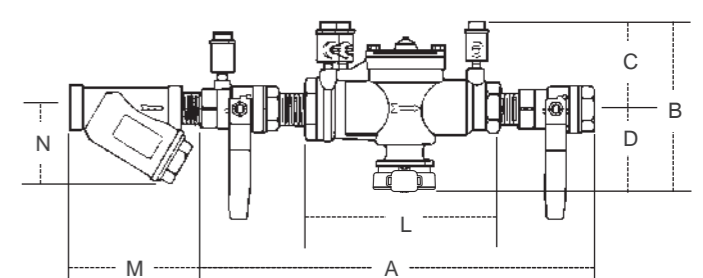

Materials: 1/4" – 2"

Lead Free* cast copper silicon alloy body construction, silicone rubber disc material in the first and second check plus the relief valve. Replaceable polymer check seats for first and second checks. Removable relief valve seats. Stainless steel cover bolts. Standardly furnished with NPT body connections. Model LF009QT furnished with quarter-turn, full port, resilient seated, Lead Free* cast copper silicon alloy body ball valve shutoffs.

Materials: 2 1/2" – 3"

- FDA-approved epoxy-coated cast iron unibody with plastic seats
- Relief valve with stainless steel seat and trim
- Lead Free* cast copper silicon alloy body ball valve test cocks

Insulated Enclosure

The WattsBox insulated enclosure is available for Series LF009/LF009-FS. For more information download ES-WB at watts.com.

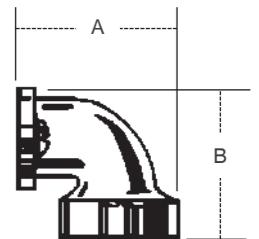
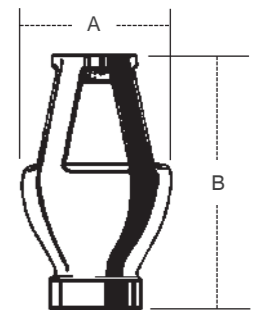



LF009-EN-202212

SIZE	DIMENSIONS (APPROX.)								WEIGHT	
	A	B	C	D	L	M	N	lb	kg	
1/4	10	4 3/8	3 3/8	1 1/4	5 1/2	2 3/8	2 1/2	5	2	
3/8	10	4 3/8	3 3/8	1 1/4	5 1/2	2 3/8	2 1/2	5	2	
1/2	10	5 1/8	3 3/8	2 1/2	5 1/2	2 3/4	2 1/4	5	2	
3/4	10 3/4	6 1/4	3 1/2	2 3/4	6 3/4	3 1/8	2 3/4	6	3	
1	14 1/2	6 1/4	3	3 1/4	9 1/2	3 3/4	3	12	5	
1 1/4	17 3/8	6 3/4	3 1/2	3 3/4	11 3/8	4 1/16	3 1/2	15	6	
1 1/2	17 3/8	6 3/4	3 1/2	3 3/4	11 3/8	4 1/8	4	16	7	
2	21 3/8	8 1/4	4 1/2	4 1/4	13 1/2	5 1/8	5	30	13	

Dimensions – Weight

Size: 2 1/2" – 3"

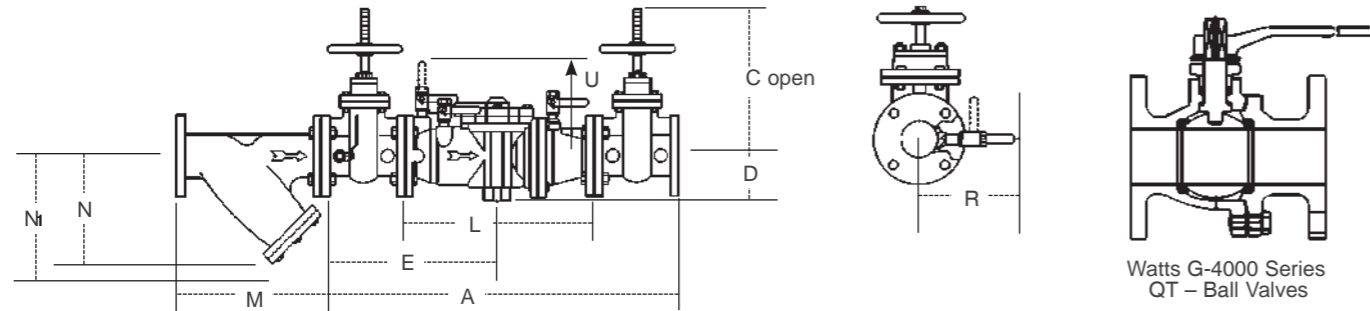

Watts G-4000 Series QT – Ball Valves

STRAINER SIZE	DIMENSIONS (APPROX.)						WEIGHT		
	M	N	N†	lb	kg				
2 1/2	65	10	254	6 1/2	165	9 3/4	248	28	12.7
3	80	10 1/8	257	7	178	10	254	34	15.4

†Clearance for servicing

MODEL	SIZE	DIMENSIONS (APPROX.)								WEIGHT	
		A	C	D	E	L	R	U	lb	kg	
LF009LF	2 1/2	—	—	4 1/2	—	18 3/8	—	10 3/8	76	34.5	
LF009OSY	2 1/2	33 3/4	15 3/8	4 1/2	16 3/8	18 3/8	7 3/4	10 3/8	166	75.3	
LF009NRS	2 1/2	33 3/4	11 3/8	4 1/2	16 3/8	18 3/8	7 3/4	10 3/8	161	73.0	
LF009LF	3	—	—	4 1/2	—	18 3/8	—	10 3/8	76	34.5	
LF009OSY	3	34 1/4	18 1/2	4 1/2	16 3/8	18 3/8	8 3/4	10 3/8	198	89.8	
LF009NRS	3	34 1/4	12 3/4	4 1/2	16 3/8	18 3/8	8 3/4	10 3/8	191	86.6	

Characteristic Curves

Performance as established by an independent testing laboratory

The asterisk (*) indicates the typical maximum system flow rate (7.5 ft/sec, 2.3 m/sec).

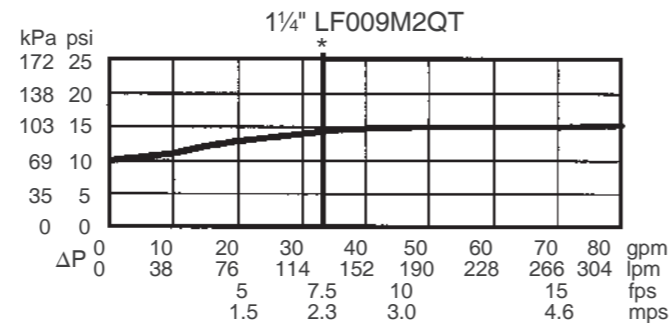
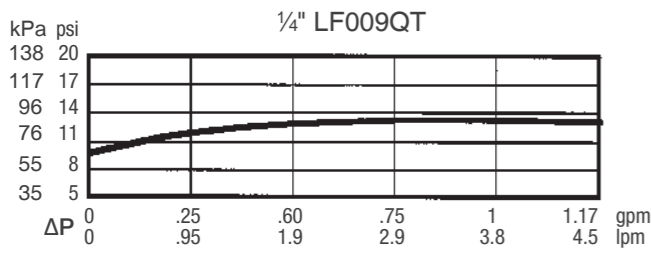

LF009-EN-202212

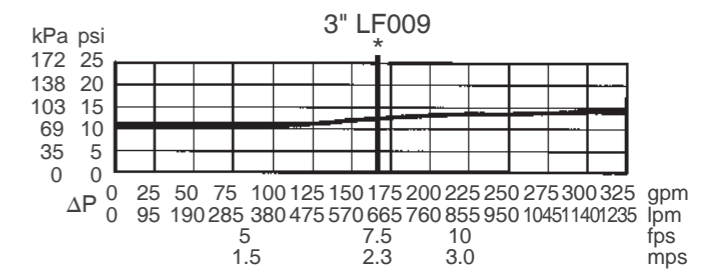
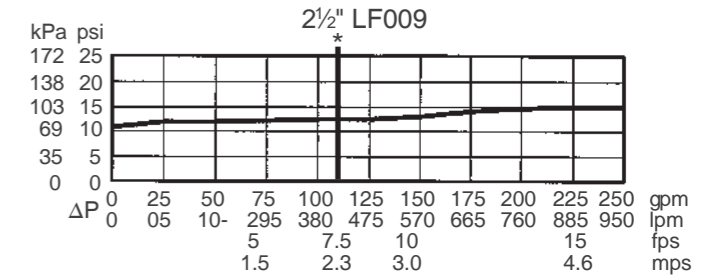
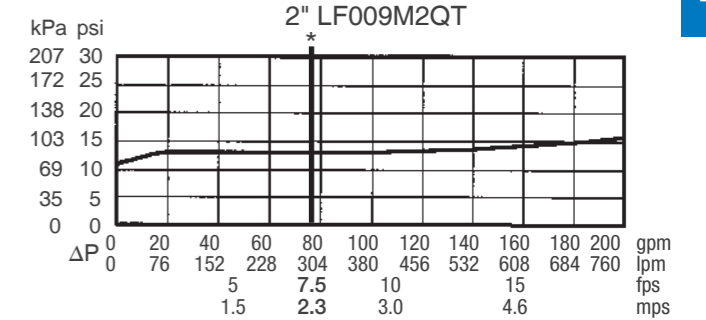
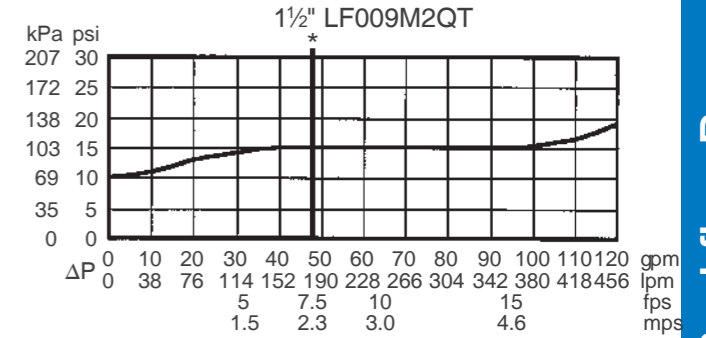
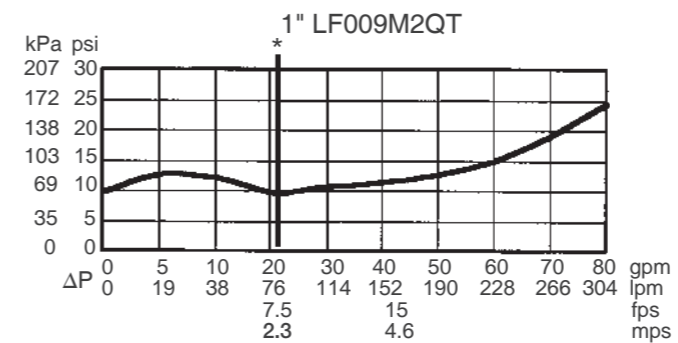
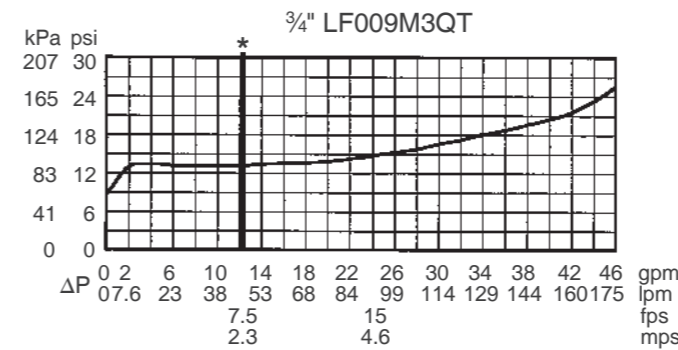
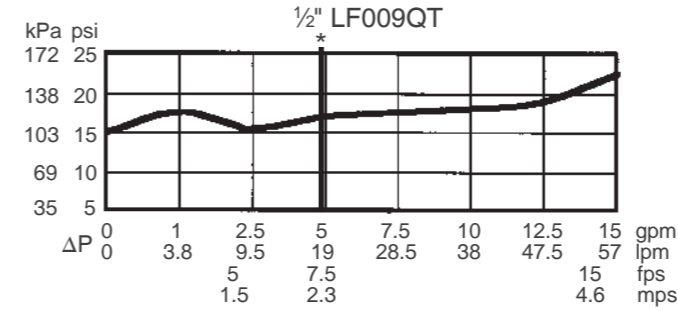
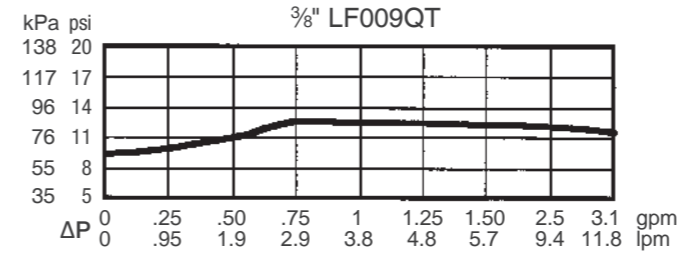



LF909-FS Small-EN-202212

Series LF909-FS Small

Reduced Pressure Zone Assemblies LF909-FS

- LF909-FS
3/4"–1"
- LF909M1-FS
1 1/4"–2"

Series LF909-FS Reduced Pressure Zone Assemblies are designed to provide superior cross-connection control protection of the potable water supply in accordance with national plumbing codes and containment control for water authority requirements. This series can be utilized in a variety of installations, including health hazard cross-connections in plumbing systems or for containment at the service line entrance. The series features Lead Free* construction to comply with Lead Free* installation requirements. With its exclusive design incorporating the "air-in/water-out" principle, the series provides maximum relief valve discharge during the emergency conditions of combined backsiphonage and backpressure with both checks fouled. Model LF909-FS-QT is standardly furnished with full port, resilient-seated, and Lead Free* cast copper silicon alloy ball valve shutoffs. Sizes 3/4" and 1" shutoffs have tee handles. This series includes an integrated flood sensor to detect excessive water discharges from the relief valve. The sensor relays a signal that triggers notification to facility personnel, helping to avoid the possibility of ruinous flooding and costly damage.

Features

- Modular design
- Replaceable seats
- Compact for installation ease
- Horizontal or vertical (up or down) installation on limited sizes only
- No special tools required for servicing
- Integrated sensor for flood detection
- Flood alert feature activated with add-on sensor connection kit, compatible with BMS and cellular communication

Specification

A Reduced Pressure Zone Assembly shall be installed at each cross-connection to prevent backsiphonage and backpressure of hazardous materials into the potable water supply. The assembly shall consist of a pressure differential relief valve located in a zone between two positive seating check valves. Backsiphonage protection shall include provision to admit air directly into the reduced pressure zone via a separate channel from the water discharge channel, or directly into the supply pipe via a separate vent. The assembly shall be constructed using Lead Free* cast copper silicon materials. The Lead Free* reduced pressure zone assembly shall comply with state codes and standards, where applicable, requiring reduced lead content. The assembly shall include two tightly closing shutoff valves before and after the assembly, test cocks and a protective strainer upstream of the No. 1 shutoff valve. The assembly (specify Model LF909 for temperatures up to 140°F (60°C)) shall meet the requirements of ASSE Standard 1013; AWWA Standard C-511-92 CSA B64.4; FCCCHR of USC Manual Section 10. Listed by IAPMO (UPC). SBCCI (Standard Plumbing code). The assembly shall be a Watts LF909QT, and shall include strainer (-S) and integrated sensor for flood detection (-FS).

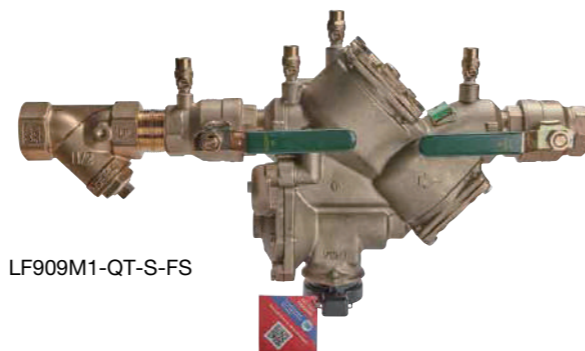

LF909M1-QT-S-FS

How It Operates

The unique relief valve construction incorporates two channels: one for air, the other for water. When the relief valve opens the right channel admits air to the top of the reduced pressure zone, relieving the zone vacuum. The left channel then drains the zone to atmosphere. (See diagram to the right.) Therefore, if both check valves foul, and simultaneous negative supply and positive backpressure develop, the relief valve uses the air-in/water-out principle to stop potential backflow.

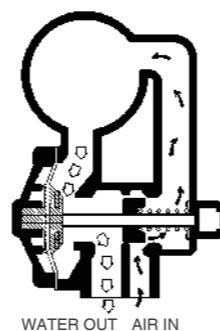

Standards

- AWWA C-511-92
- FCCCHR of USC Manual Section 10
- IAPMO (UPC), SBCCI (Standard Plumbing code)
- Tested and Certified by NSF International

Approvals



Listed by IAPMO
Listed by SBCCI
Approved by the Foundation for Cross-Connection Control and Hydraulic Research at the University of Southern California (QT and S models)
Vertical "flow-up" approval only on 3/4" and 1" sizes (Model LF909QT)

Pressure-Temperature

- Temperature Range: 33°F – 140°F (0.5°C – 60°C) continuous; 180°F (82°C) intermittent
- Maximum Working Pressure: 175 psi (12.1 bar)

Material

Component	Material
Body	Lead Free* Cast Copper Silicon Alloy
Check Seats	909 Celcon®
Relief Valve Seats	Stainless Steel 909
Test Cocks	Lead Free* Cast Copper Silicon Alloy



LF909-FS Small-EN-202212

Model/Option

- FS Integrated sensor for flood detection
- QT Quarter-turn ball valves
- S Bronze strainer

Connections

- 3/4" – 1" 909-NPT Female threaded body connection
- 1 1/4" – 2" 909-M1-NPT Male threaded body connection

Insulated Enclosure

The WattsBox insulated enclosure is available for this series. For more information download ES-WB at watts.com.

Installation Dimensions

Dimensions — Weights

When installing a drain line, use Model 909AG air gaps on Series LF909 Small back flow preventers. Model 909EL elbows are for air gaps on backflow preventers in vertical installations.

Model 909AG Air Gaps

Iron Body No.	Desc.	909 DRAIN		OUTLET		DIMENSIONS		WEIGHT			
		Size in.	mm	Size in.	mm	A in.	B in.	lb	kg		
909AG-C	Air Gap	3/4, 1	19, 25	1	25	3/4	83	4/8	124	1 1/2	.7
909EL-C	Elbow	3/4, 1	19, 25	—	—	2 3/8	60	2 3/8	60	3/4	.2
909AG-F	Air Gap	1 1/4-2	32-50	2	50	4 3/8	111	6 3/4	171	3 3/4	1.5
909EL-F	Elbow	1 1/4-2	32-50	—	—	3 3/8	92	3 3/8	92	2	.9

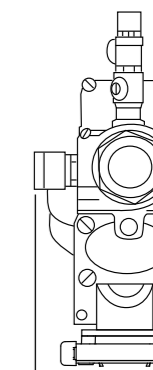
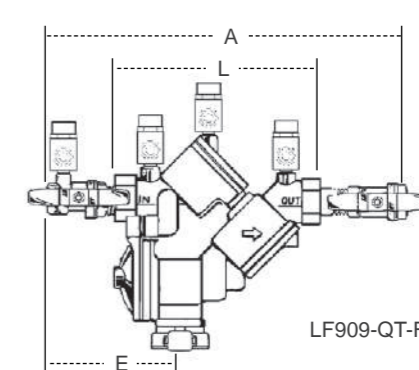
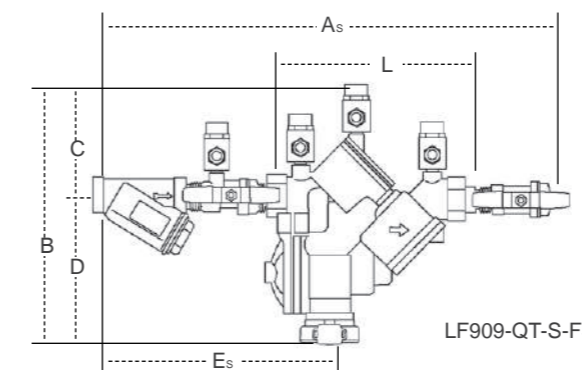
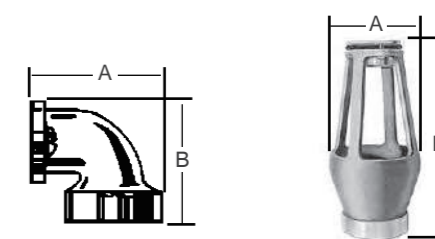
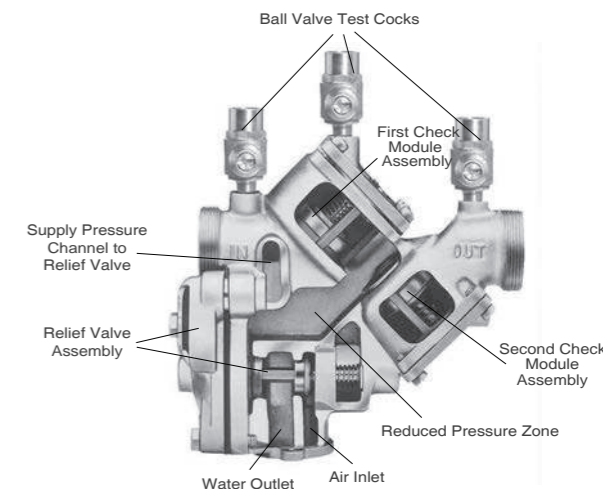

LF909, LF909M1

SIZE (DN)	DIMENSIONS										WEIGHT		
	A in.	As in.	B in.	C in.	D in.	E in.	Es in.	L in.	P in.	QT lb	QT kg	QT-S lb	QT-S kg
3/4"	14 3/8	18 1/8	9 3/8	4	5 3/8	6 3/4	10 3/16	7 1/16	3 3/8	14	6.4	15.6	7.1
1"	15 3/8	19 3/8	9 3/8	4	5 3/8	7	11	7 1/16	3 3/8	15	6.8	17.5	7.9
1 1/4" M1	18 1/2	23 3/8	12 3/4	5 1/2	7 3/8	7 1/2	12 3/16	10 3/8	5 1/4	40	18.1	42.8	19.4
1 1/2" M1	19	24 3/8	12 3/4	5 1/2	7 3/8	7 1/2	12 3/8	10 3/8	5 1/4	40	18.1	44.0	20.0
2" M1	19 1/2	25 1/8	12 3/4	5 1/2	7 3/8	7 3/4	13 3/16	10 3/8	5 1/4	40	18.1	47.4	21.5



Characteristic Curves

As compiled from documented Foundation for Cross-Connection Control and Hydraulic Research of the University of Southern California lab tests.
 ◊ Typical maximum system flow rate (7.5 ft/s)

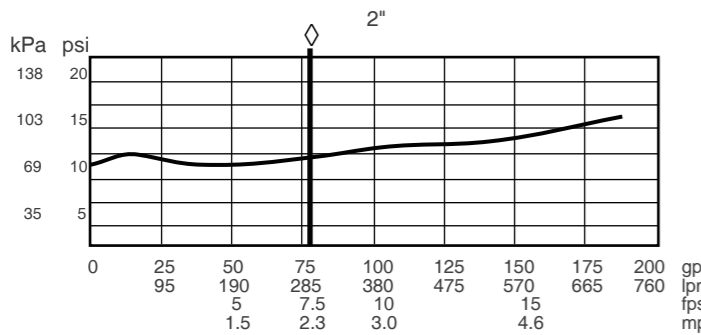
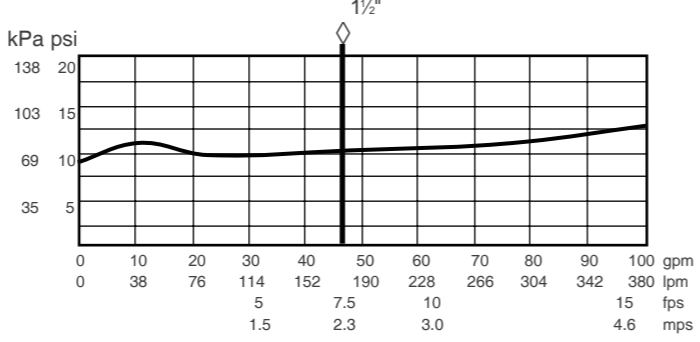
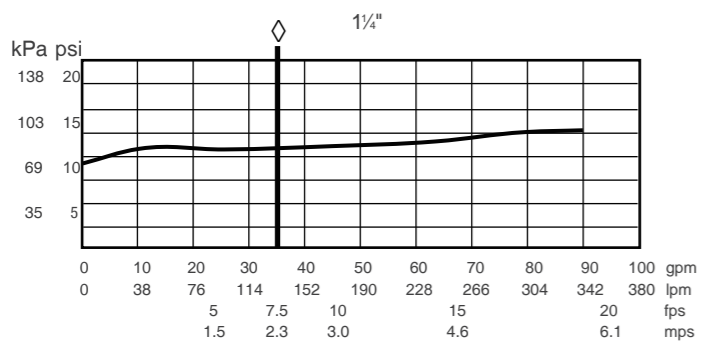
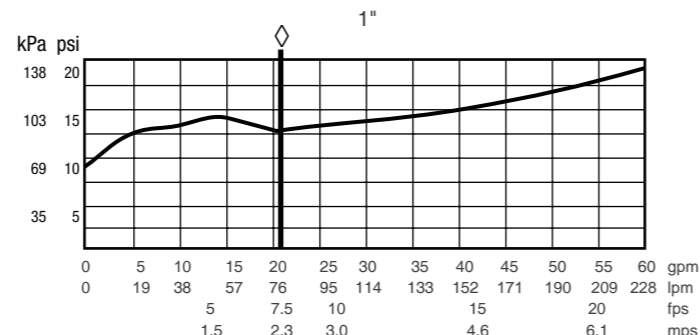
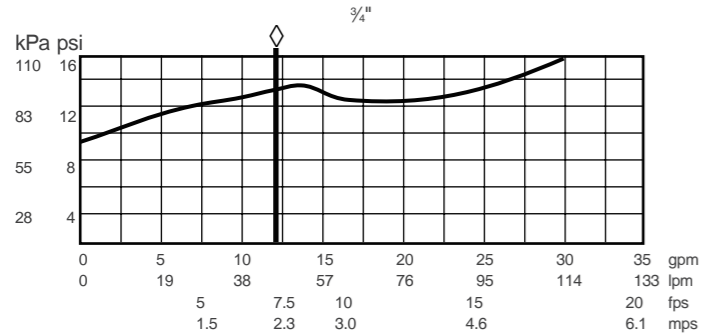

Series LF909-FS

Reduced Pressure Zone Assemblies

Size: 2 1/2" – 10"

Series LF909-FS Reduced Pressure Zone Assemblies are designed to provide cross-connection control protection of the potable water supply in accordance with national plumbing codes. This series can be utilized in a variety of installations, including health hazard cross-connections in plumbing systems or for containment at the service line entrance. With its exclusive relief valve design incorporating the "air-in/water-out" principle, it provides substantially improved relief valve discharge performance during the emergency conditions of combined backsiphonage and backpressure with both checks fouled. The coating on this backflow assembly uses ArmorTek™ technology to resist corrosion due to microbial induced corrosion (MIC) or exposed metal substrate. Series LF909-FS features Lead Free* construction to comply with Lead Free* installation requirements.

With an upgrade of the SentryPlus™ Alert technology, Series LF909-FS contains an integrated flood sensor to detect excessive water discharge from the relief valve. When activated through an add-on sensor connection kit, the flood sensor relays a signal that triggers notification to qualified service personnel who can take corrective action, thus avoiding the possibility of ruinous flooding and costly damage. The add-on sensor connection kit is available for both third-party building management systems, or BMS, and cellular communications.

(For more information, refer to Installation, Maintenance, and Repair Manual, Series 909, LF909-FS, 909RPDA.)

Features

- Replaceable seats
- Stainless steel internal parts
- No special tools required for servicing
- Captured spring check assemblies
- Fused epoxy coated and lined checks
- Utilizes advanced ArmorTek™ coating technology to resist corrosion of internals
- Industrial-strength sensing hose
- Field reversible relief valve
- Air-in/water-out relief valve design provides maximum capacity during emergency conditions
- Integrated sensor for flood detection

Pressure-Temperature

- Temperature Range: 33°F-110°F (0.5°C-43°C) continuous, 140°F (60°C) intermittent
- Maximum Working Pressure: 175psi (12.06 bar)

Material

Component	Material
Check Valve Bodies	FDA epoxy coated cast iron
Seats	Stainless steel
Trim	Stainless steel
Relief Valve Body	2 1/2"-3" Lead Free* cast copper silicon alloy 4"-10" FDA epoxy coated cast iron
Test Cocks	Lead Free* copper silicon alloy

Standards

- AWWA C511-92
- IAPMO PS 31, SBCCI (Standard Plumbing Code)
- USC manual for Cross-Connection Control, 8th Edition

Watts reserves the right to change or modify product design, construction, specifications, or materials without prior notice and without incurring any obligation to make such changes and modifications on Watts products previously or subsequently sold.



Series LF909-FS
Technology integrated for flood detection upon activation with Sensor Connection Kit

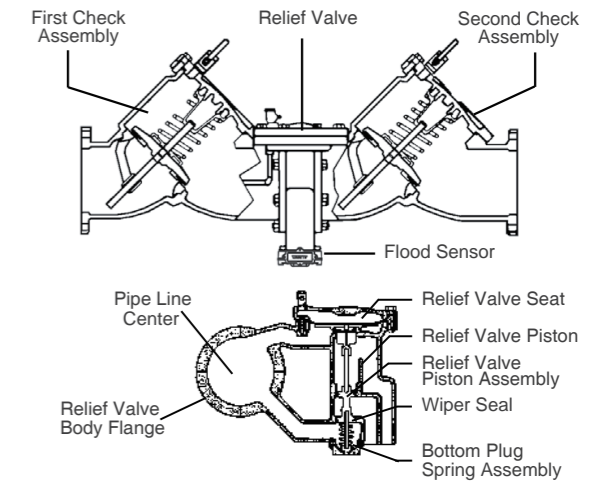

Now Available
Add-on sensor connection kits for activation of the newly integrated flood sensor.

Specification

A Reduced Pressure Zone Assembly shall be installed at each cross-connection to prevent backsiphonage and backpressure backflow of hazardous materials into the potable water supply. The assembly shall consist of a pressure differential relief valve located in a zone between two positive seating check valves and captured springs. Backsiphonage protection shall include provision to admit air directly into the reduced pressure zone via a separate channel from the water discharge channel. The assembly shall include two tightly closing shutoff valves before and after the valve and test cocks. The Lead Free* Reduced Pressure Zone Assembly shall comply with state codes and standards, where applicable, requiring reduced lead content. The assembly shall meet the requirements of ASSE Std. 1013; AWWA Std. C511-92; CSA B64.5; and UL Classified File No. EX3185. Listed by IAPMO (UPC). Approved by the Foundation for Cross-Connection Control and Hydraulic Research at the University of Southern California. The valve body shall utilize a coating system with built in electrochemical corrosion inhibitor and microbial inhibitor. The assembly shall be a Watts Series LF909-FS.

Approvals



Approved by the Foundation for Cross-Connection Control and Hydraulic Research at the University of Southern California.



LF909-FS-EN-202212

Available Models and Options

The notation after the model name indicates the features or options on the device.

- LF Without shutoff valves
- NRS Non-rising stem resilient seated gate valves
- OSY UL/FM outside stem-and-yoke resilient seated gate valves
- S-FDA FDA epoxy coated strainer
- ALERT With SentryPlus™ Alert flood detection system

Note: The installation of a drain line is recommended. When installing a drain line, an air gap is necessary.

How It Operates

The unique relief valve construction incorporates two channels: one for air, the other for water. When the relief valve opens, as in the accompanying air-in/water-out diagram, the right-hand channel admits air to the top of the reduced pressure zone, relieving the zone vacuum. The channel on the left then drains the zone to atmosphere. Therefore, if both check valves foul, and simultaneous negative supply and positive backpressure develop, the relief valve uses the air-in/water-out principle to stop potential backflow.

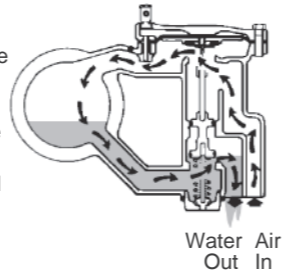

Installation Dimensions

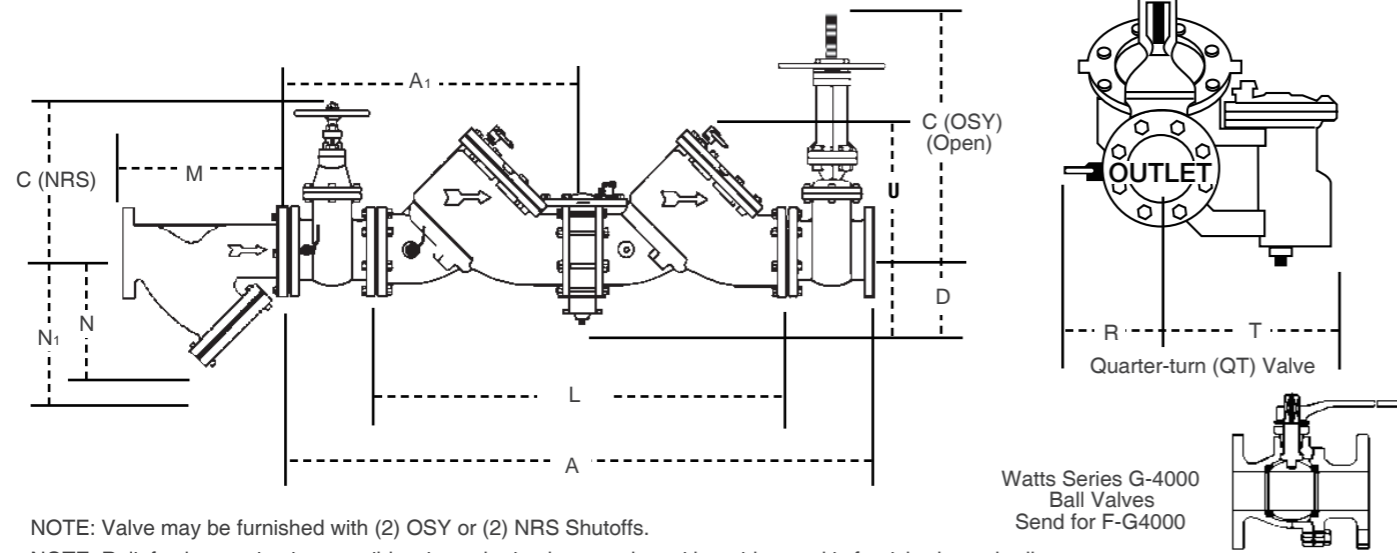

NOTE: Valve may be furnished with (2) OSY or (2) NRS Shutoffs.

NOTE: Relief valve section is reversible—it can be implemented on either side—and is furnished standardly.

SIZE	DIMENSIONS (APPROX.)										WEIGHT						
	A		A ₁		C clearance for check		D	L	U	R	R (QT)	T	NRS		OSY		QT
in.	in.	in.	in.	(OSY)*	(NRS)	in.	in.	in.	in.	in.	in.	lb	kg	lb	kg	lb	kg
2½	41½	20¾	16¾	9¾	5¼	26½	11	4	16	9½	195	88.4	198	89.8	182	82.6	
3	42½	21¼	18¾	10¼	5¼	26½	11	5	16	9½	225	102	230	104	190	86	
4	55½	27¾	22¾	12¾	6	37¾	14	6	19¾	14¾	455	206	470	213	352	160	
6	65½	33	30¾	16	6	44½	16	11	26	14¾	718	326	798	362	762	346	
8	78½	39¾	37¾	19½	9¼	55½	21	11¼	11¼	19¼	1350	612	1456	660	2286	1037	
10	93½	46¾	45¾	23½	9¼	67½	21	12½	12½	21	2160	980	2230	1011	3716	1685	

*UL, FM approved backflow preventers must include UL/FM approved OSY gate valves.

Strainer Dimensions

Size	Dimensions						Weight	
	M		N1†		N		lb	kg
in.	in.	mm	in.	mm	in.	mm	lb	kg
2½	10	254	10	254	6½	165	28	12.7
3	10½	267	10	254	7	178	34	15.4
4	12½	308	12	305	8¼	210	60	27
6	18½	470	20	508	13½	343	133	60
8	21½	549	22¾	578	15½	394	247	112
10	26	660	28	711	18½	470	370	168

† – Dimension required for screen removal.



LF909-FS-EN-202212

Air Gap Dimensions

When installing a drain line on Series 909 backflow preventers that are installed horizontally, use Series 909 AG air gaps.

Iron Body	Ordering	Assembly	Dimensions						Weight	
			A		B		C		lb	kg
Model No.	Code	Sizes & Series	in.	mm	in.	mm	in.	mm		
909AG-F	881378	1¼" – 3" 009/909 1¼" – 2" 009 M1 2" 009 M2	4¾	111	6¾	171	2	51	3.25	1.47
909AG-K	881385	4" – 6" 909 8" – 10" 909 M1	6¾	162	9¾	244	3	76	6.25	2.83
909AG-M	881387	8" – 10" 909	7¾	187	11¼	286	4	102	15.5	7.03

For flange size backflow preventers installed vertically (flow down), a fabricated air gap is recommended.

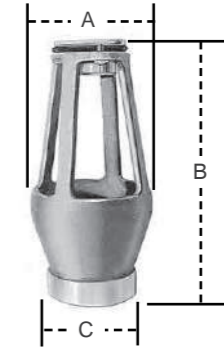

Characteristic Curves

*Typical maximum flow rate (7.5 feet/sec.)

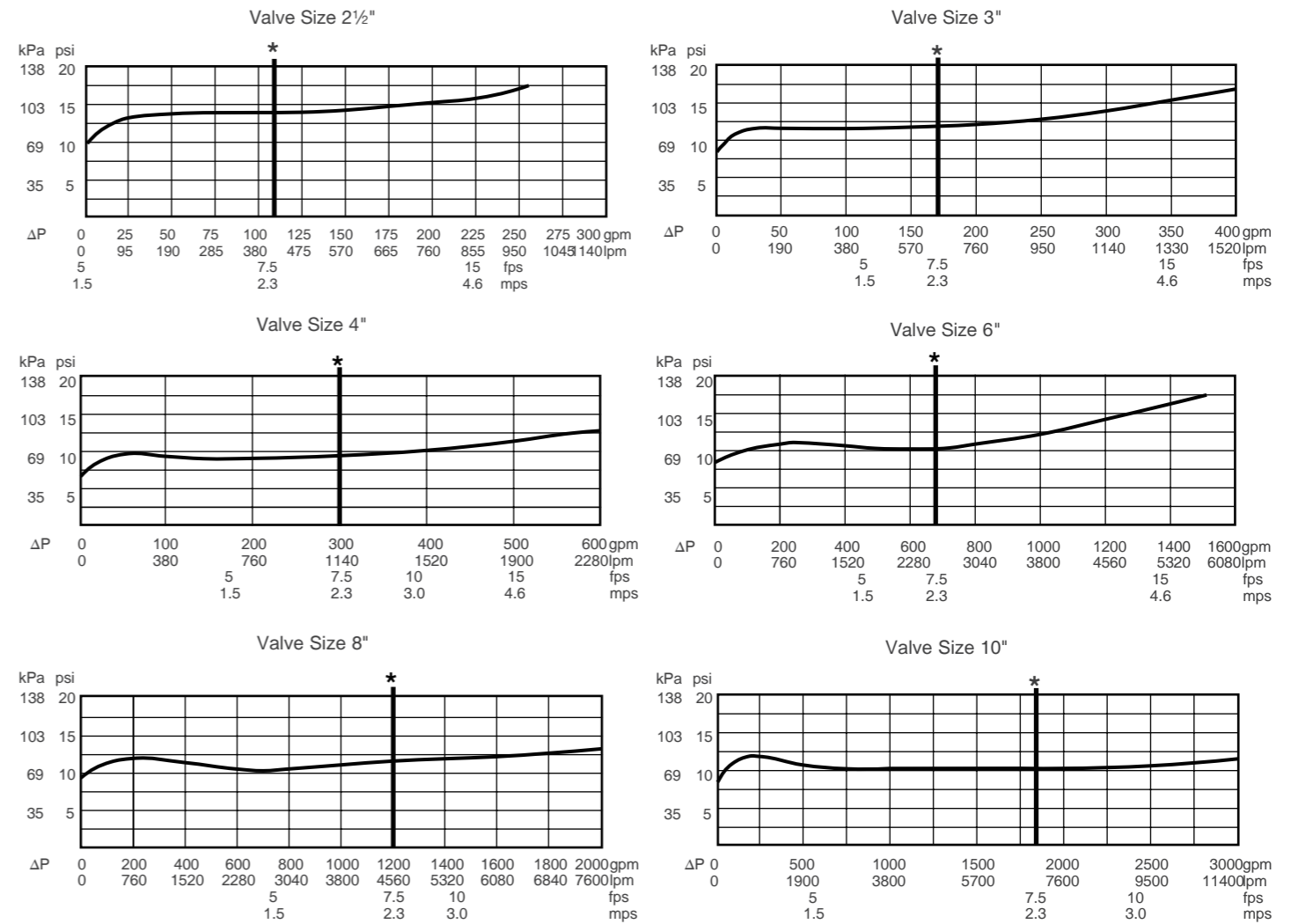



757/757N-EN-202212

Series 757, 757N

Double Check Valve Assemblies

Size: DN 65- DN250

Series 757, 757N Double Check Valve Assemblies are used to prevent backflow of non-health hazard pollutants that are objectionable but not toxic, from entering the potable water supply system. Series 757, 757N may be installed under continuous pressure service and may be subjected to backpressure and backsiphonage. Series 757, 757N consists of two independently operating check valves, two shutoff valves, and four test cocks.

Features

- Extremely compact design
- 70% Lighter than traditional designs
- 304 (Schedule 40) Stainless steel housing & sleeve
- Groove fittings allow integral pipeline adjustment
- Patented tri-link check provides lowest pressure loss
- Unmatched ease of serviceability
- Available with grooved butterfly valve shutoffs
- Available for horizontal, vertical or N pattern installations
- Replaceable check disc rubber
- Sizes 2½", 3" and 4" available with quarter-turn ball valve shutoffs

Pressure-Temperature

- Temperature Range: 33°F – 140°F (0.5°C – 60°C)
- Maximum Working Pressure: 175psi (12.1 bar)

Material

Component	Material
Housing & Sleeve	304 (Schedule 40) Stainless Steel
Elastomers	EPDM, Silicone and Buna-N
Tri-link Checks	Noryl®, Stainless Steel
Check Discs	Reversible Silicone or EPDM
Test Cocks	Lead Free* Bronze Body
Pins & Fasteners	300 Series Stainless Steel
Springs	Stainless Steel

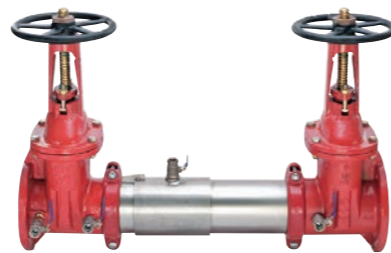

757OSY

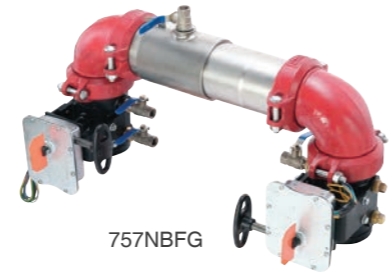

757NBFG



757OSY (Vertical)



Approvals

- Approved by the Foundation for Cross-Connection Control and Hydraulic Research at The University of Southern California (FCCCHR-USC)
- AWWA C510-97



Installation Dimensions

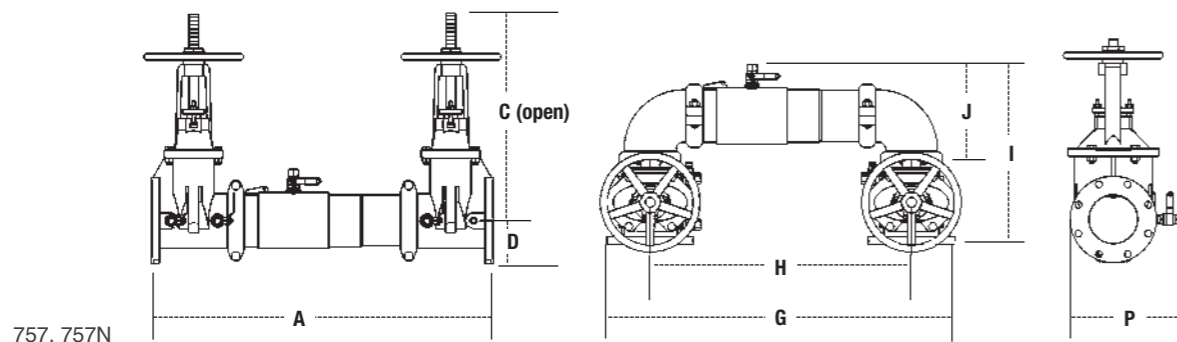

757, 757N



757/757N-EN-202212

SIZE	DIMENSIONS									WEIGHT			
	A	C (OSY)	C (NRS)	D	G	H	I	J	P	757NRS	757OSY	757N NRS	757N OSY
mm	mm	mm	mm	mm	mm	mm	mm	mm	mm	kgs.	kgs.	kgs.	kgs.
DN 65	781	416	238	89	738	546	393	223	234	52	57	56	60
DN 75	806	479	260	94	768	565	435	233	267	59	66	65	72
DN 100	857	578	310	102	838	597	470	252	284	73	73	83	83
DN 150	1105	765	406	140	1137	851	589	332	381	124	134	142	152
DN 200	1264	959	506	170	1375	1019	697	399	437	199	218	233	252
DN 250	1467	1162	605	208	1676	1257	826	440	508	327	354	404	431

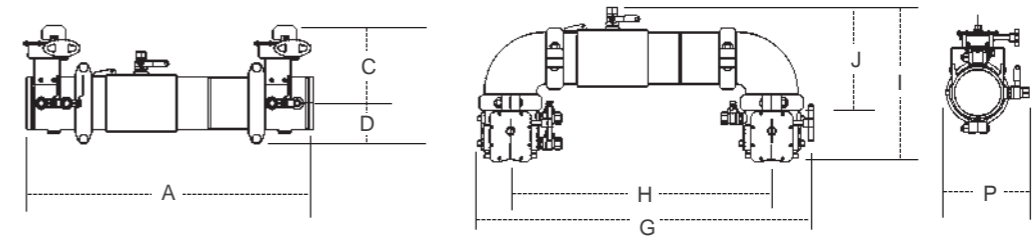

757BFG, 757NBFG

SIZE	DIMENSIONS									WEIGHT	
	A	C	D	G	H	I	J	P	757BFG	757N BFG	
mm	mm	mm	mm	mm	mm	mm	mm	mm	mm	kgs.	
DN 65	705	203	89	759	546	379	223	229	25	29	
DN 75	718	211	94	779	565	392	233	241	24	30	
DN 100	737	227	94	811	597	412	252	254	28	38	
DN 150	927	254	127	1097	845	500	332	267	53	71	
DN 200	1086	311	165	1297	1019	592	399	361	118	153	

Noryl® is a registered trademark of SABIC Innovative Plastics Holding BV.

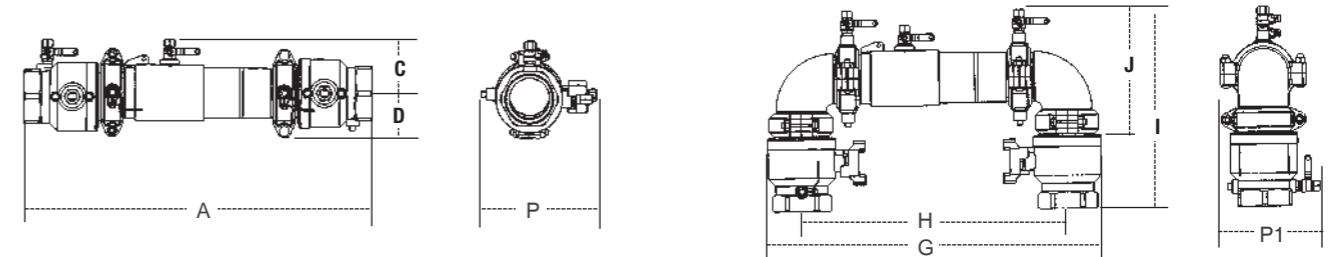

757QT

SIZE	DIMENSIONS										WEIGHT	
	A	C	D	G	H	I	J	P	P1	QT	QTN	
mm	mm	mm	mm	mm	mm	mm	mm	mm	mm	kgs.	kgs.	
DN 65	692	124	175	768	622	407	289	287	287	18	23	
DN 75	718	124	175	768	622	420	289	287	287	23	27	
DN 100	800	124	175	768	622	465	289	287	287	32	36	



757/757N-EN-202212

Characteristic Curve

Series 757, 757N flow curves as tested by Underwriters Laboratory. Flow characteristics collected using butterfly shutoff valves

Horizontal Vertical N - Pattern

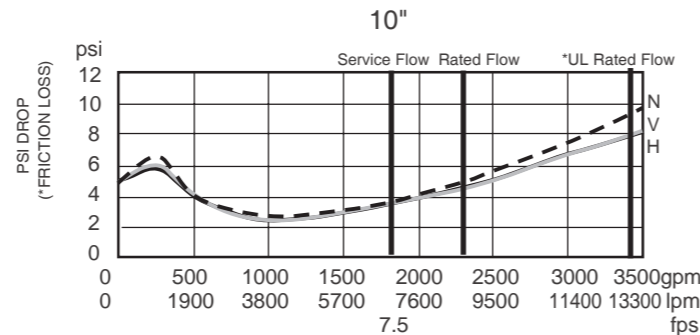
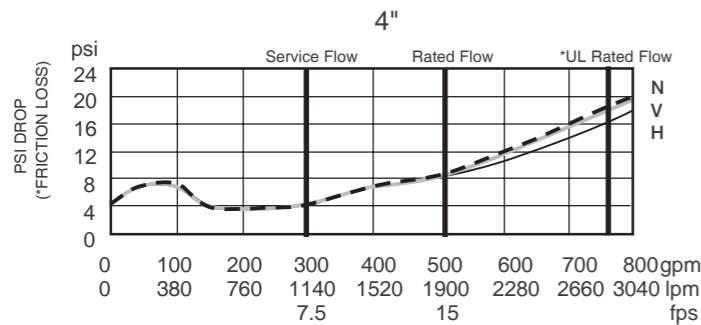
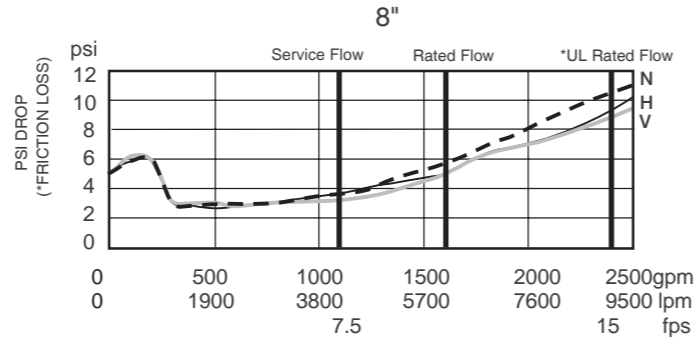
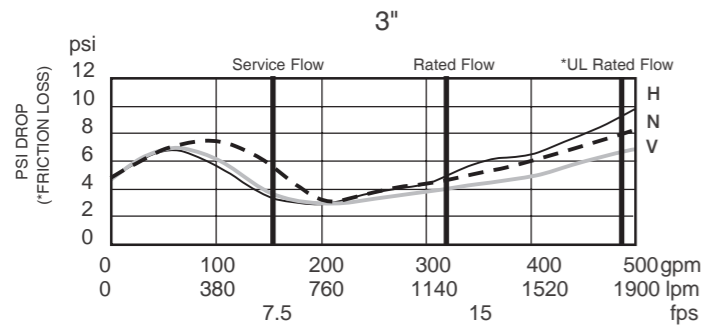
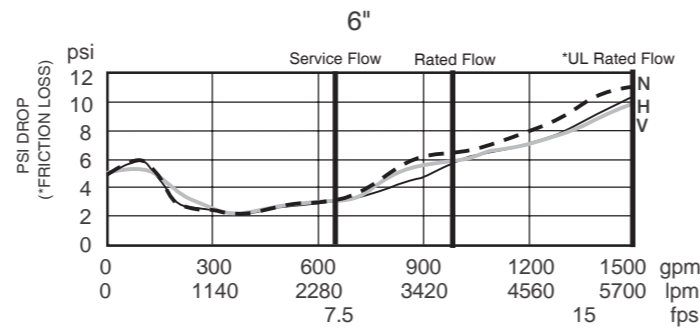
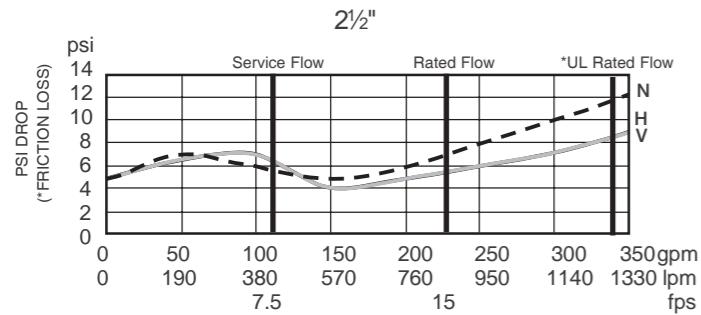

Flow capacity chart identifies valve performance based upon rated water velocity up to 25fps

- Service Flow is typically determined by a rated velocity of 7.5fps based upon schedule 40 pipe.
- Rated Flow identifies maximum continuous duty performance determined by AWWA.
- UL Flow Rate is 150% of Rated Flow and is not recommended for continuous duty.
- AWWA Manual M22 [Appendix C] recommends that the maximum water velocity in services be not more than 10fps.



BA BM-EN-202208

Series BA BM

Backflow Preventer

Size: DN15-DN50

The BA BM backflow preventer protects the drinking water network by interrupting the continuity of the supply, emptying and evacuating to waste in case of danger of water being turned back into the main pipeline.

Features

- Easy maintenance thanks to modular sub-sets
- Piston technology on the relief valve, without membrane: easy mounting/dismantling, reinforced longevity
- Easy access
- Compact design and space-saving
- Reduced head losses
- High quality materials
- Connection: Male threaded union nuts (BSP) ISO 228-1

Pressure-Temperature

- Operating temperature: Maxi. 65°C
- Permissible operating pressure(PFA) in water: 10 bar

Material

NO.	Component	Materials
1	Body	Brass DZR
2	Relief valve body	PA
3	Cover	Brass DZR
4	Screws	Stainless steel
5	Bearing	Stainless steel
6*	Upstream valve	POM Stainless steel Brass
7*	Downstream valve	POM Stainless steel Brass
8*	Relief valve module	POM Stainless steel Brass
9	Funnel	PVC
10-11-12	Test cock pressure	Brass DZR
13	Inlet zone	
14	Intermediate zone	
15	Outlet zone	

*Subassembly: consult us

Installation Dimensions

DN	D	V	L1	L2	H1	H2	H3	W
"	mm	mm	mm	mm	mm	mm	mm	mm
1/2	15	32	122	201	168,5	103	65,5	53
3/4	20	32	122	201	168,5	103	65,5	53
1	25	40	157	252	238	156	82	76
1 1/4	32	40	157	252	238	156	82	76
1 1/2	40	50	220	336	303,5	202,5	101	115
2	50	50	220	336	303,5	202,5	101	115



Approvals

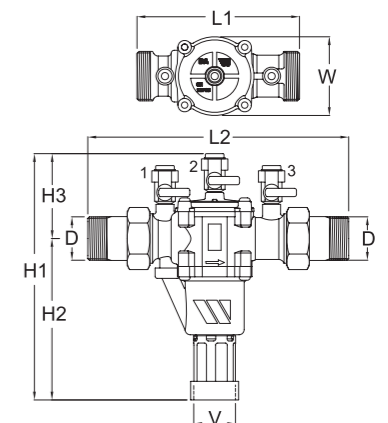
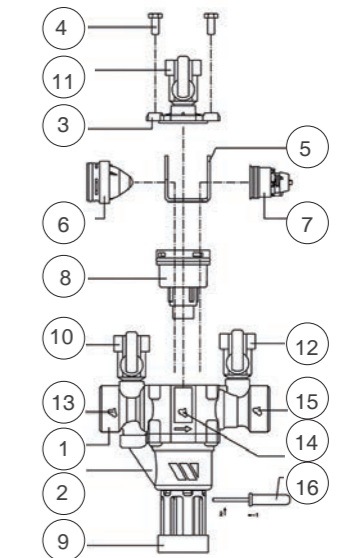



BA BM-EN-202208

Characteristic Curves

Direction for use:

- Solid line: Valve completely open

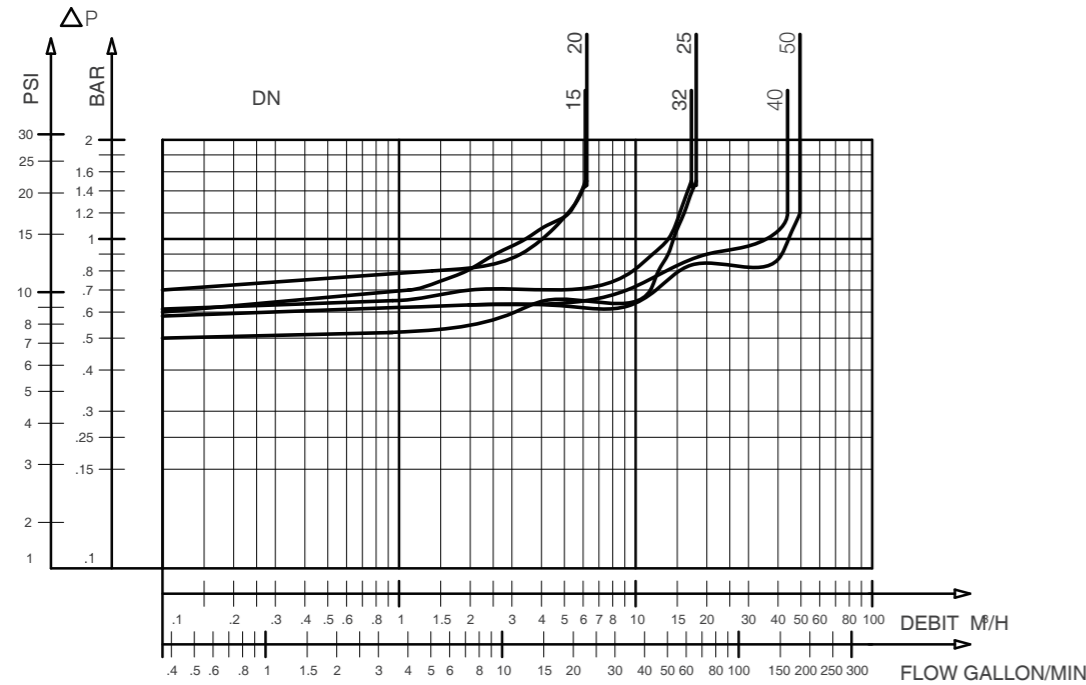

BA BM-Headloss chart

Application

Designed to protect drinking water supply networks against the backflow of risk fluids up to category 4 according to EN1717. The device is designed to prevent any backflow of polluted water into the drinking water supply network as a result of back pressure or back siphonage when the pressure upstream of the device is lower than the pressure downstream of it.

For systems liable to generate pollution risks such as:

- Professional networks: industrial facilities, surface treatment, chemical industry
- Sanitary networks: hospitals, laboratories, dialysis centers, water treatment
- Technical networks: heating, air conditioning, irrigation, water dispensers, sprinklers

Installation

Directions for installation:

- total accessibility
 - non-submersible installation
 - purge carefully all air from the installation (non polluted atmosphere)
 - the discharge valve must be able to cope with the discharge flow rate
 - protection against frost or extreme temperatures
 - in the case of an upstream diversion in the area right in front of the RPZ, it is necessary to install a check valve between the diversion and the RPZ.
 - always manipulate the upstream valve slowly.
- The protection device must be installed by a qualified technician.

Installation specification :

The correct installation requires:

- upstream : ball valve fitting + filter (with drain cock)
- downstream : ball valve fitting



BA 4760-EN-202208

Series BA 4760

Backflow Preventer

Size: DN65-DN250

The BA 4760 backflow preventer with controllable reduced pressure zone is designed to protect drinking water networks. It prevents from polluted water backflows in the public and the private networks. This sanitary safety device is compliant with the EN12729 standard.

Features

- Three pressure areas: upstream, intermediate and downstream hamber
- Two independent non-return devices separating the intermediate zone from each other areas, normally closed when there is no water
- A discharge device (in open air) in the intermediate zone, normally open in water off position

Pressure-Temperature

- Operating temperature: Maxi. 65 °C
- Permissible operating pressure (PFA) in water: 10 bar

Material

NO. Component		Materials
1 Body	DN 65 to 80	Cast iron
	DN 100 to 250	Ductile iron
2 Cap	DN 65 to 80	Cast iron
	DN 100 to 250	Ductile iron
3 Membrane		EPDM
4 Closing system	DN 65 to 150	Brass
	DN 250	Bronze
5 Rings		Stainless steels
6 Closing system seat	DN 65 to 80	PPO
	DN 100 to 250	Bronze
7 Closing system stem	DN 65	Stainless steels
	DN 80 to 250	
8 Drain valve stem		Brass
9 Drain valve seat	DN 65 to 100	Stainless steels
	DN 150 to 250	Stainless steels
10 Drain valve head	DN 65	Bronze
	DN 80 to 250	PPO
11 Drain valve guide	DN 65	Brass
	DN 80	POM
	DN 100 to 250	Bronze
12 O-ring		EPDM
13 Spring		Stainless steels
14 Flat seal		EPDM
15 Funnel		Ductile iron
16 Ball valve		Brass
17 Stop guide		Brass
18 Disc		Stainless steels



Approvals

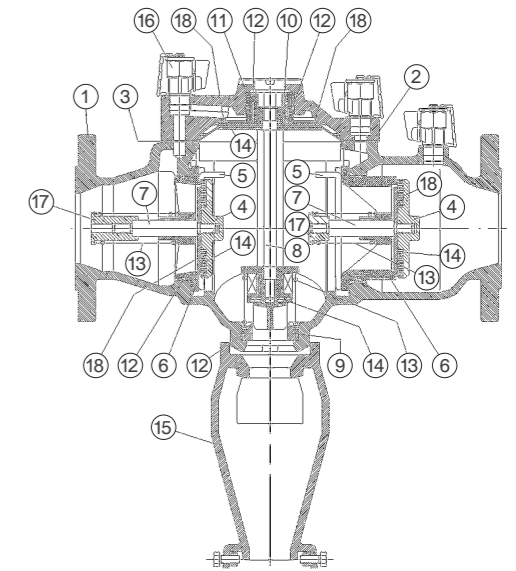

Application

The BA 4760 backflow preventer is designed to protect drinking water networks against risky fluids (up to category 4) according to NF EN1717.

The device is designed to prevent any backflow of polluted water into the drinking water supply network as a result of back pressure or back siphonage when the pressure upstream of the device is lower than the pressure downstream of it.

For systems liable to generate pollution risks such as:

- Professional networks: industrial facilities, surface treatment, chemical industry
- Sanitary networks: hospitals, laboratories, dialysis centers, water treatment
- Technical networks: heating, air conditioning, irrigation, water dispensers, sprinklers



BA 4760-EN-202208

Installation Dimensions

DN	A	B	C	D	E	F	Max. acceptable torques*
2 1/2	65	185	356	155	326	63	180
3	80	200	440	173	337	63	200
4	100	220	530	201	434	80	255
6	150	285	630	230	456	80	310
8	200	340	763	272	499	80	390
10	250	395	763	272	499	80	390

*Maximum torque for tightening bolts of the backflow preventor cover

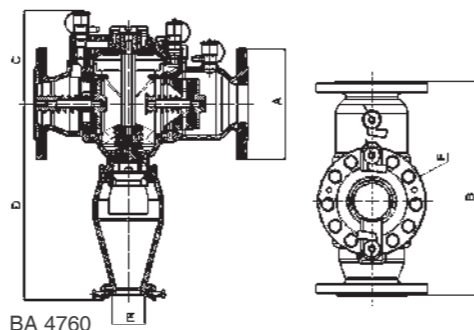

BA 4760

Characteristic Curves

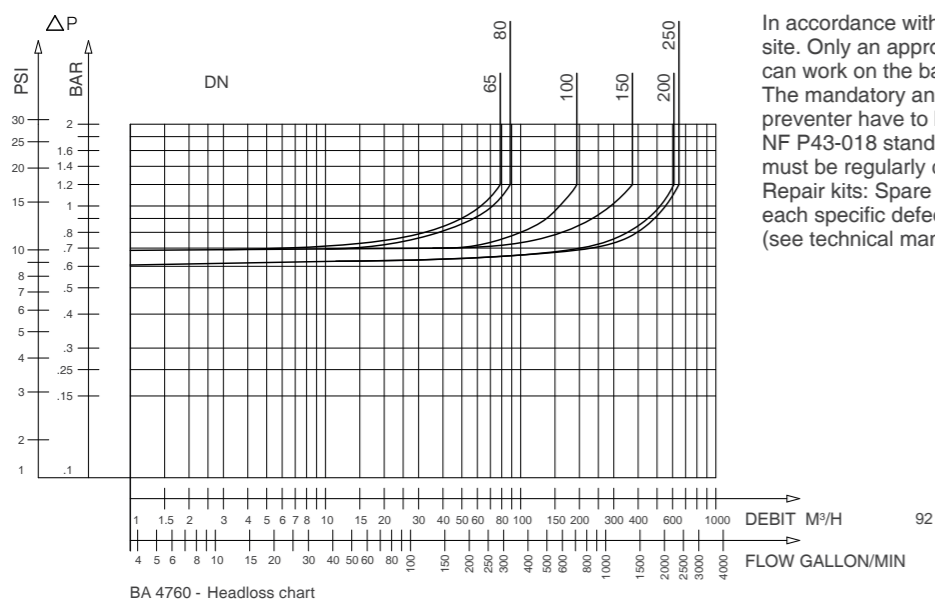

BA 4760 - Headloss chart

Installation

Directions for installation:

- total accessibility
 - non-submersible installation
 - purge carefully all air from the installation (non-polluted atmosphere)
 - the discharge valve must be able to cope with the discharge flow rate
 - protection against frost or extreme temperatures
 - in the case of an upstream diversion in the area right in front of the RPZ, it is necessary to install a check valve between the diversion and the RPZ.
 - always manipulate the upstream valve slowly for a progressive pressurization of the RPZ.
- According to the national recommendations, the backflow preventer 4760:
- have to be installed by a qualified technician.
 - have to be subject to a commissioning notice in accordance with the installation rules of BA set of protection.

Implantation, it is mandatory to install:

To make a BA set of protection as described in NF EN 1717, the BA 4760 backflow preventer must be installed with the following accessories:

International construction Standards :
NF EN12729 - EN 1717
Flange connection according to EN 1092-1/2

Approvals
ACS
BELGAQUA

- Upstream:
- shut-off valve (butterfly valve)
 - A strainer with flushing valve type Y333P

- Downstream:
- shut-off valve (butterfly valve)

Maintenance

In accordance with the regulations, maintenance must be done on site. Only an approved maintainer (with an authorization number) can work on the backflow preventer. The mandatory annual operating check of the BA backflow preventer have to be done with a control device compliant with the NF P43-018 standard (WATTS 2234900M2 type). This equipment must be regularly checked at least once every two years. Repair kits: Spare parts are available and allow the replacement of each specific defective parts of BA 4760 backflow preventer (see technical manual).



LF7R-EN-201909

Series LF7R

Dual Check Valve

Size: DN15-DN25

Series LF7R Dual Check Valves are designed for non-health hazard residential water system containment and continuous pressure applications, such as the drinking water supply service entrance or individual outlets.

Features

- Lead-Free Dual Check Valves, uses two compact replaceable check modules
- Installed immediately downstream of the residential water meter
- Can be installed vertically or horizontally
- Available with a combination of inlet/outlet sizes, types of thread and end connection

Pressure-Temperature

- Nominal Pressure: 175 psi (12.1 bar)
- Temperature Range: 0.5°C~82°C continuous

Test Pressure

Hydraulic
120 psi

Material

Component	Material
Body	Lead-Free Copper Silicon Alloy
Disc	Santoprene
Seat	Plastic
Trim	Plastic
Elastomers	EPDM
Springs	Stainless Steel

Connection Type	Connection Code	Sizes Available
National Pipe Thread Female	2	1/2, 3/4, 1
National Pipe Thread Female longer length	2L	1/2, 3/4, 1
National Pipe Thread Male	3	1/2, 3/4, 1
Female Meter Thread	4	1
Female Meter Thread (Swivel)	10	3/4, 1
Male Meter Thread	5	1

Union (U) Connections available on all inlet/outlet types and sizes

Installation Dimensions

Model	Size	Dimensions		Weight	
		A	B	lbs.	kgs.
LF7RU2-2	1/2	3 5/8 92	1 7/8 48	.7	.32
	3/4	3 5/8 92	1 7/8 48	.7	.32
	1	3 7/8 99	1 7/8 48	.8	.36
LF7RU2L-2*	1/2	4 7/16 113	1 7/8 48	.774	.351
	3/4	4 5/16 109	1 7/8 48	.819	.371
LF7RU2-U2	1	4 1/4 108	1 7/8 48	.866	.393
LF7R10-U2	3/4	3 11/16 93	1 7/8 48	.9	.41
LF7R10-U2L*	1x3/4	4 7/8 124	1 7/8 48	1.020	.462
LF7R10-U3	1	4 13/16 122	1 7/8 48	1.7	.77

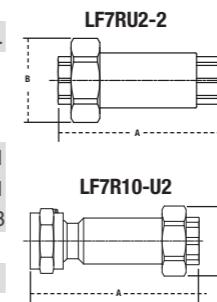

Specification

- Design Standard: ANSI/ASSE 1024
- Connection Standard: ANSI B1.20.1

Approvals

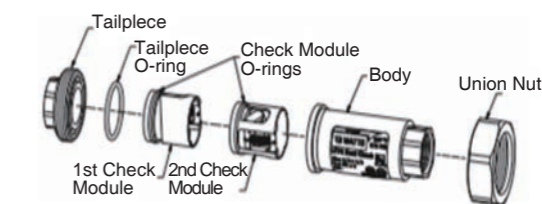

Characteristic Curves

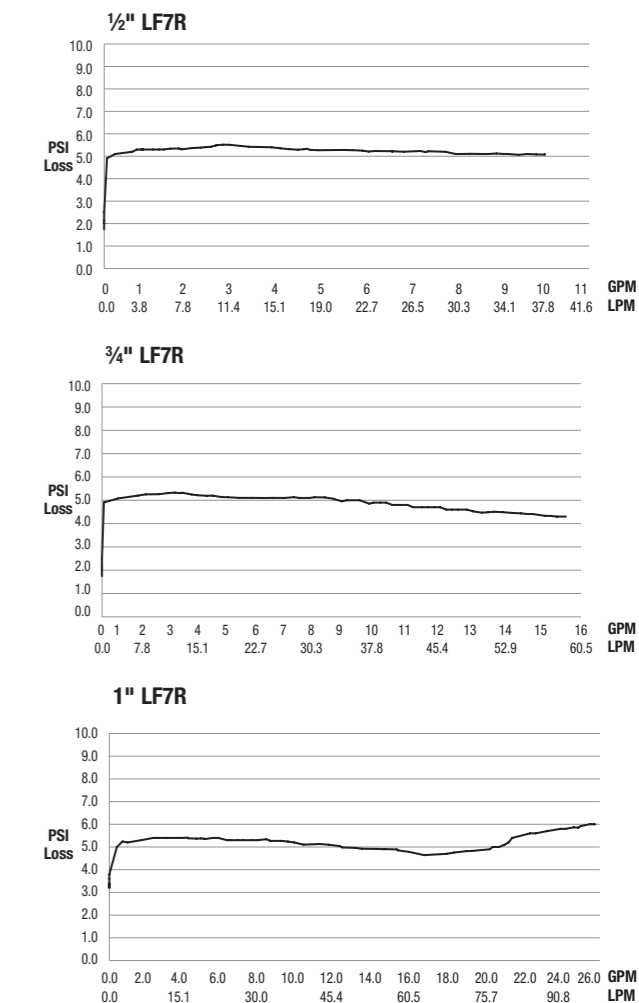



LF8/ LF8B-EN-201909

Series LF8/ LF8B

Hose Connection Vacuum Breakers

Size: DN20

Series LF8 is a line of unique vacuum breakers specially made to permit the attachment of portable hoses to hose thread faucets. Designed to prevent the flow of contaminated water back into the potable water supply, these devices require no plumbing changes and screw directly onto sill cocks.

Features

- Lead-Free Copper silicon alloy body
- LF8: Secured with Allen head set screw. No draining feature
- LF8B Furnished with break-away set screw to provide a tamper-resistant installation. Equipped to allow sill cock to be drained
- Stainless steel working parts for longevity
- Durable rubber diaphragm and disc for consistent positive seating

Pressure-Temperature

- Nominal Pressure: 125 psi (8.6 bar)
- Temperature Range: 0.5°C~82°C continuous

Test Pressure

Hydraulic
100 psi

Material

Component	Material
Body	Copper Silicon Alloy
Disc	EPDM
Seat	Copper Silicon Alloy
Trim	Stainless Steel
Elastomers	EPDM, Nitrile, Neoprene
Pins & Fasteners	Zinc Plated Steel
Springs	Stainless Steel

Installation Dimensions

Size	Dimensions				Weight	
	A		B		oz.	gm.
in.	in.	mm	in.	mm		
3/4 HT	1 1/2	38	1 3/8	35	4.0	113.4

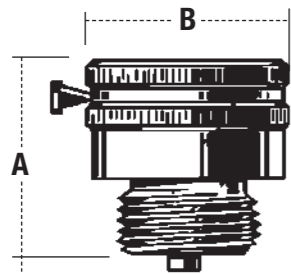

Specification

- Design Standard: ANSI A112.1.3, ASSE 1011
- Connection Standard: ANSI B1.20.1

Approvals



Characteristic Curve

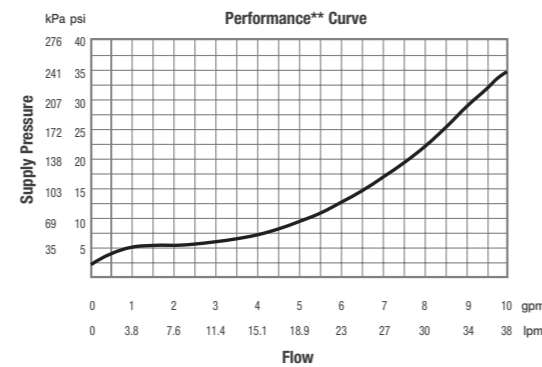

LFMMV-EN-201909

Series LFMMV

Thermostatic Mixing Valve

Size: DN15-DN25

Series LFMMV Thermostatic Mixing Valves maintain and limit mixed hot water to a desired, selectable temperature. The LFMMV-M1 uses a double throttling design to control both the hot and cold water supply to the mixed outlet. The superior flow characteristics of this valve provide accurate temperature control ($\pm 1.7^\circ\text{C}$) with a low-pressure drop across the rated flow range.

Features

- Lead-Free cast copper silicon alloy body construction
- Solid wax hydraulic principle thermostat assures dependable mixing of hot and cold water
- Thermostat controls both hot and cold water
- Adjustment cap with locking feature
- Integral filter washers and check valves

Pressure-Temperature

- Nominal Pressure: 150 psi (10.55 bar)
- Inlet Temperature Range: Hot inlet: 49°C ~82°C
Cold inlet: 4°C ~ 29°C
- Outlet Temperature: 27°C ~ 49°C

Material

Part	Material
Body	Lead-Free* cast copper silicon alloy
Disc	Stainless steel
Thermostat Assembly	Copper
O-Rings	Buna-N; EPDM
Pistons	Polysulfone (PSU)
Springs	Stainless Steel

Installation Dimension

Size	Model	Dimensions				Weight					
		A	B	C	D	lbs.	kgs.				
in.	mm	in.	mm	in.	mm	in.	mm				
1/2	15	4 7/8	124	5 7/16	137	3 3/16	80	5/8	16	1.8	0.8
3/4	20	4 7/8	124	5 7/16	137	3 3/16	80	5/8	16	2.4	1.1
1	25	5 5/16	135	5 5/8	143	3 3/8	86	3/4	20	3.0	1.4

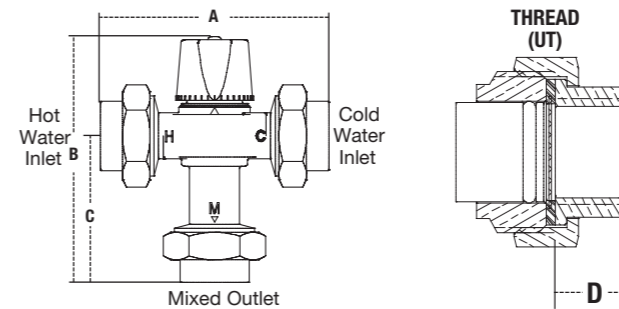

Specification

- Design Standard: ASSE 1017, ASSE 1069, ASSE 1070, IAPMO UPC
- Connection Types: NPT threaded, available in pex, quick-connect, cpvc end, w/press
- Pressure Test: Pneumatic 70 psi
- The maximum pressure difference between hot and cold water supplies: 25%
- Hot water inlet to outlet temperature differential: 3°C above set point
- Flow rate range: 0.5 GPM-20 GPM

Approvals

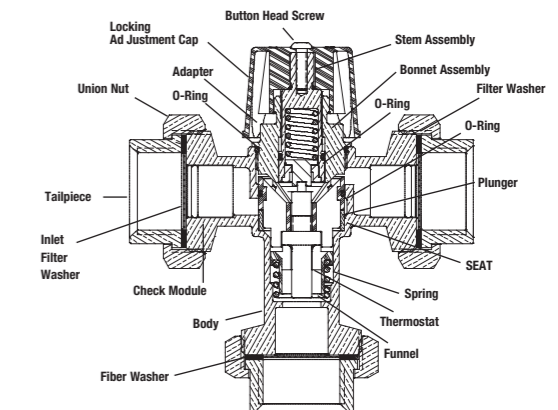

Characteristic Curves

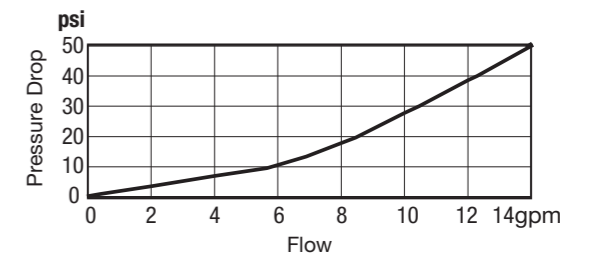



LFN170/ LFN170-CSUT-EN-201909

Series LFN170/ LFN170-CSUT

Hot Water Master Tempering Valves

Size: DN20-DN50

Watts Series LFN170 hot water master tempering valves are especially designed for use on larger hot water supply systems for mixing hot and cold water for a variety of applications to extend the hot water supply.

Features

- Lead Free brass body construction
- LFN170-M3 uses paraffin-based thermostat to sense and adjust outlet temperatures
- Dirt and lime resistant poppet and seat design
- Virtual shutoff if supply pressure fails
- Vandal-resistant locking mechanism to secure temperature setting
- Factory tested

Pressure-Temperature

- Nominal Pressure: 125 psi (8.6 bar)
- Inlet Temperature Range: Hot inlet: 42°C ~82°C, Cold inlet: 4°C ~ 27°C
- Outlet Temperature: 32°C ~ 82°C.

Test Pressure

Pneumatic
70 psi

Material

Component	Material
Body	Brass
O-Rings	EPDM
Spring	Stainless Steel
Piston	Polysulfone
Thermostat	Copper/ Paraffin

Installation Dimensions

Model	Body Inlets	Check Stop	Body Outlet	Dimensions										Weight									
				A	B	C	D	E	F	G	H	J	lbs.	kgs.									
3/4 LFN170-M3	3/4	-	3/4	-	4 1/2	114	-	3 1/2	89	-	1 7/16	36	3 5/8	92	4 7/8	124	2 15/16	75	4.8	2.2			
3/4 LFN170-M3 CSUT	3/4	3/4	9 1/4	235	4 1/2	114	11 7/16	291	3 1/2	89	1 13/16	46	1 7/16	36	3 5/8	92	4 7/8	124	2 15/16	75	9.8	4.5	
1 LFN170-M3	1	-	1	-	4 9/16	116	-	3 1/2	89	-	1 7/16	36	3 5/8	92	4 7/8	124	2 15/16	75	4.8	2.2			
1 LFN170-M3 CSUT	-	3/4	1	10 1/8	264	4 9/16	116	12 9/16	319	3 1/2	89	1 13/16	46	1 7/16	36	3 5/8	92	4 7/8	124	2 15/16	75	10.3	4.9
1 1/4 LFN170-M3	1 1/4	-	1 1/4	-	6 1/16	154	-	3 7/16	87	-	1 3/4	44	3 1 11/16	94	5 1/4	133	4 1/2	114	9.4	4.3			
1 1/4 LFN170-M3 CSUT	-	1 1/4	1 1/4	12 1/16	306	6 1/16	154	15 1/16	383	3 7/16	87	2 1/2	64	1 3/4	44	3 1 11/16	94	5 1/4	133	4 1/2	114	19.3	8.8
1 1/2 LFN170-M3	1 1/2	-	1 1/2	-	6 1/16	154	-	3 7/16	87	-	1 3/4	44	3 1 11/16	94	5 1/4	133	4 1/2	114	9.1	4.1			
1 1/2 LFN170-M3 CSUT	-	1 1/4	1 1/2	13 1/4	337	6 1/16	154	16 1/4	413	3 7/16	87	2 1/2	64	1 3/4	44	3 1 11/16	94	5 1/4	133	4 1/2	114	19.8	9.0
2 LFN170-M3	2 (Hot) 1 1/2 (Cold)	-	2	-	6 7/16	164	-	3 3/16	81	-	2 1/16	52	3 7/8	98	5 3/8	137	4 1/2	114	10.4	4.7			
2 LFN170-M3 CSUT	-	1 1/4	2	13 3/4	349	6 7/16	164	16 3/4	425	3 3/16	81	2 1/2	64	2 1/16	52	3 7/8	98	5 3/8	137	4 1/2	114	21.3	9.7



Specification

- Design Standard: ASSE 1017, IAPMO CUPC
- Connection Standard: ASME B1.20.3
- Hot water inlet to outlet temperature differential: 3°C above set point
- Minimum flow rate: 3 GPM

Approvals

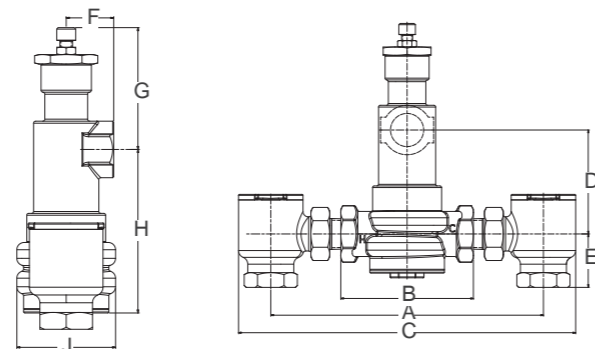

LF1170/LFL1170-EN-201909

Series LF1170/LFL1170

Hot Water Temperature Control Valves

Size: DN15-DN25

Series LF1170, LFL1170 Hot Water Temperature Control Valves are specifically designed for mixing hot and cold water on hot water supply systems. This series features a "double throttling" design which combines the control of the hot and cold water to provide a sensitive response to changes in water temperature passing through the mixing chamber.

Features

- Lead-Free cast copper silicon alloy body construction
- Solid wax hydraulic principle thermostat assures dependable mixing of hot and cold water
- Thermostat controls both hot and cold water
- Integral filter washers and check valves
- Adjustment cap with locking feature

Pressure-Temperature

- Nominal Pressure: 150 psi (10 bar)
- Inlet Temperature Range: Hot inlet: 49°C ~93°C, Cold inlet: 4°C ~ 29°C
- Outlet Temperature Range: LF1170: 32°C ~ 71°C, LFL1170: 16°C ~ 49°C

Material

Component	Material
Body	Lead-Free* copper silicon alloy
Springs	Stainless steel
Thermostat Assembly	Copper
O-Rings	EPDM
Pistons	Polysulfone

Installation Dimensions

Size	Model	Dimensions				Weight					
		A	B	C	D						
in.		in.	mm	in.	mm	in.	mm	lbs.	kgs.		
1/2		4 7/8	124	5 7/16	137	3 3/16	80	5/8	16	1.8	0.8
3/4	LF1170-UT-M2	4 7/8	124	5 7/16	137	3 3/16	80	5/8	16	2.4	1.1
1		5 5/16	135	5 5/8	143	3 3/8	86	3/4	20	3.0	1.4

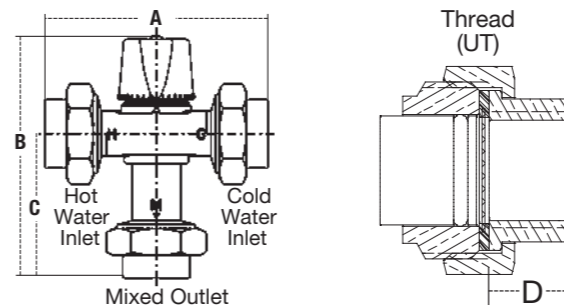

Specification

- Design Standard: ASSE 1017
- Connection Types: NPT threaded, available in solder, pex, quick-connect, cpvc end, w/press
- Pressure Test: Pneumatic 70 psi
- Minimum flow rate to maintain set temperature: 0.5 GPM
- Hot water inlet to outlet temperature differential: 3°C above set point
- The maximum pressure difference between hot and cold water supplies: 25%

Approvals

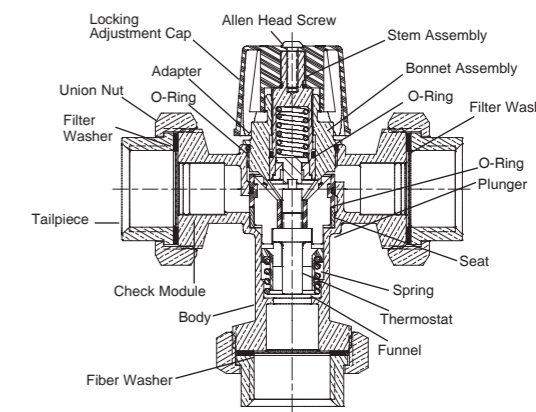

Characteristic Curve

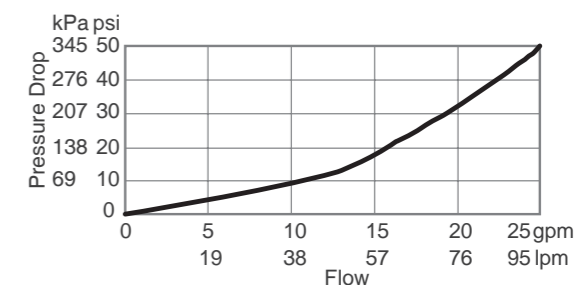



61C, 62C, 61CM-EN-202208

Series 61C, 62C, 61CM

Aquamix Thermostatic Mixing Valve

61C, 62C and 61CM Series Aquamix thermostatic mixing valves are available in versions with male and female connections, and 4 setpoint positions. The valve body is made of brass, which is internally and externally nickel-plated and has an additional internal teflon coating to reduce the limescale build-up caused by hard water. Each valve is equipped with two mesh strainers, one in the hot water inlet port (+) and one in the cold water inlet port (-), to safeguard correct valve operation by preventing the entry of coarse debris.

Pressure-Temperature

- Maximum primary circuit temperature: 100°C
- Maximum operating pressure: 10 bar
- Maximum differential pressure: 2 bar

Material

Component	Material
Valve body	a) internally and externally nickel-plated brass b) internal teflon coating to prevent limescale build-up
Thermostatic element	Solid expansion
Springs	Stainless steel
Disc	Brass

Installation Dimensions

61C-62C

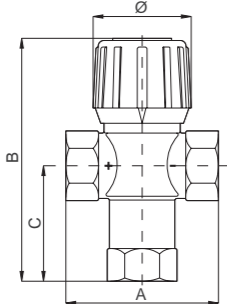

DN	A	B	C	Ø
1/2"	70	107	52	45
3/4"	70	107	52	45
1"	80	110	52	45

61CM

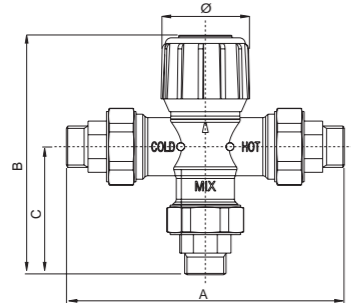

DN	A	B	C	Ø
1/2"	132	122	62	45
3/4"	136	123	66	45
1"	150	130	72	45



Application

Aquamix valves are used in domestic hot water distribution systems to ensure that the temperature of the mixed water remains constant irrespective of changes in the temperature of the hot water from the heat exchanger. The setting ranges of 61C, 62C and 61CM Series valves allow the hot water produced in the heat exchanger (whether on-demand or storage type) to be mixed directly with cold water from the mains, by setting the desired temperature.

Characteristic Curve

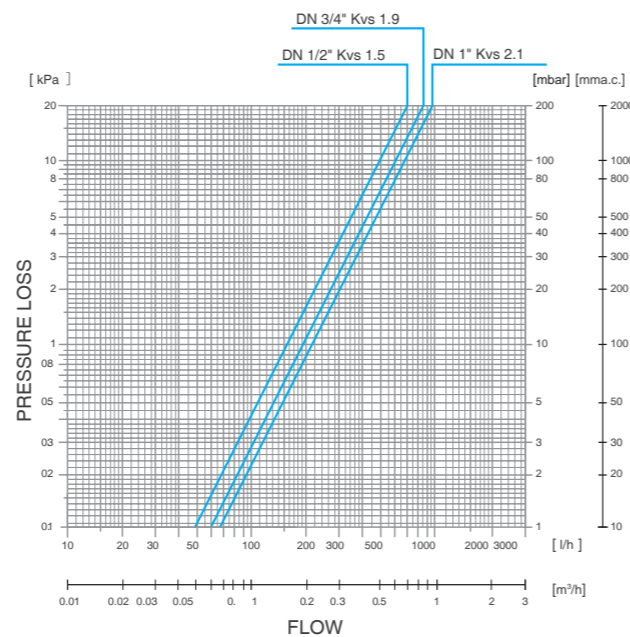

Operation

Operation is automatic and takes place by means of a heat-sensitive element in the valve body, which expands or contracts on contact with the mixed water, thus proportionally regulating the inlet of hot and cold water from the side ports according to the temperature setting. If a failure prevents the supply of cold water, a thermal stop device in the valve closes the disc to prevent the entry of hot water. This prevents the delivery of unmixed water, thereby eliminating the risk of scalding, as required by UNI EN 1111. The fluid flow rate and pressure drop of the valves can be determined from the appropriate flow curves.



61C, 62C, 61CM-EN-202208

Setting

The valve, and hence the mixed water temperature, is set manually by turning the graduated handwheel until the number on the handwheel lines up with the reference mark on the valve body. The numbers marked on the handwheel correspond to the temperatures indicated in Table 1: the valve is factory-set using hot water at 70°C and mains water at 15°C. Variation in temperature of the water in the primary circuit causes a deviation (max. ±2°C) from the set nominal values Table 2: likewise a variation in pressure between P1 and P2 (see installation diagrams) exceeding 2 bar could cause differences. You are therefore advised to equip the circuit with a balancing valve (FO-BV Series) at the cold water inlet port so as to create the same drop in pressure as occurs when the water flows through the heat exchanger. To prevent tampering, the handwheel can be locked in the required setpoint position as shown in Fig.1-2-3. The reliability of Aquamix 61C, 62C and 61CM Series thermostatic mixing valves is guaranteed by the fact that every single product undergoes testing.

Tab.1

Type	1	2	3	4
61C-61CM	32°	38°	44°	50°
62C	42°	48°	54°	60°

Tab.2

Primary circuit water °C	Setpoint positions			
	1	2	3	4
50	30	36	42	48
60	31	37	43	49
70	32	38	44	50
80	33	39	45	51
90	34	40	46	52

Installation

Aquamix 61C, 62C and 61CM Series thermostatic mixing valves are selected on the basis of the DN of the connection pipe. The valves can be installed on iron pipes (61C and 62C Series), copper pipes and plastic pipes (61CM Series) in any position (vertical or horizontal). The nickel-plating and internal teflon coating of the valve body significantly reduce and delay the build-up of limescale caused by hard water. To protect the valve disc system, fit the two mesh strainers (supplied) in the hot and cold water inlet ports.

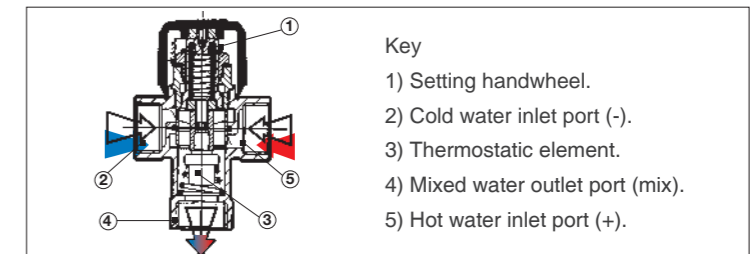

- Key
- 1) Setting handwheel.
 - 2) Cold water inlet port (-).
 - 3) Thermostatic element.
 - 4) Mixed water outlet port (mix).
 - 5) Hot water inlet port (+).

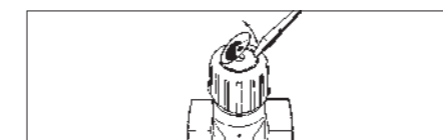

Fig.1 Remove the label with a screwdriver.

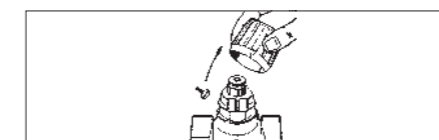

Fig.2 Unscrew the locking screw and remove the handwheel, taking care not to turn the control stem, and taking note of the corresponding setpoint for subsequent refitting.

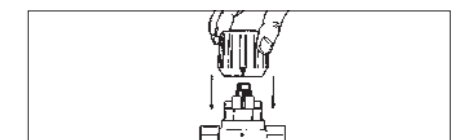
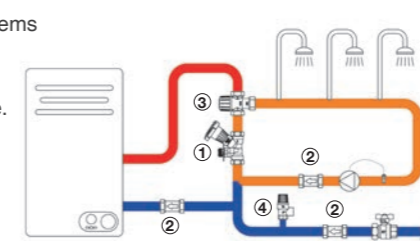

Fig.3 Refit the handwheel so that the V-shaped reference mark lines up with the mark on the valve body. In this position, the handwheel is locked.

Aquamix installation diagrams

Recirculating domestic water systems

- 1) FO-BV Series balancing valve.
- 2) Check valve.
- 3) Aquamix 61C-62C Series valve.
- 4) MSV Series safety valve.



Water heating system for domestic use

- 1) Water heater.
- 2) Safety and check valve.
- 3) Aquamix valve.

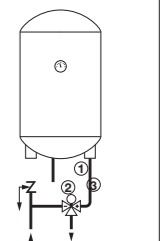

Specification text

Series 61C - AQUAMIX thermostatic mixing valve Series 61C – WATTS brand – with female threaded connections (DN 1/2" -3/4" -1"). Internally and externally nickel-plated CW617N brass body with anti-limescale internal teflon coating. Stainless steel springs. Anti-scald safety. Solid expansion heat-sensitive element. Continuous pre-setting with 4 reference positions. Mesh strainers for fitting in the side ports. PN 10bar Max. differential pressure 2 bar Temperature range: 32-50°C.

Series 61CM - AQUAMIX thermostatic mixing valve Series 61CM – WATTS brand – with male union connections (DN 1/2" -3/4" -1"). Internally and externally nickel-plated CW617N brass body with anti-limescale internal teflon coating. Stainless steel springs. Anti-scald safety. Solid expansion heat-sensitive element. Continuous pre-setting with 4 reference positions. Mesh strainers for fitting in the side ports. PN 10 bar. Max. differential pressure 2 bar. Temperature range: 32-50°C.

Series 62C - AQUAMIX thermostatic mixing valve Series 62C – WATTS brand – with female threaded connections (DN 1/2" -3/4" -1"). Internally and externally nickel-plated CW617N brass body with anti-limescale internal teflon coating. Stainless steel springs. Anti-scald safety. Solid expansion heat-sensitive element. Continuous pre-setting with 4 reference positions. Mesh strainers for fitting in the side ports. PN 10bar Max. differential pressure 2 bar. Temperature range: 42-60°C.



T70 EN-202208

Series T70

Thermostatic Mixing Valve

This appliance is recommended for all large flow applications where the mixed water temperature must be kept accurate, constant and modifiable at will.

Features

- Installation output of hot sanitary water production:
- Reduces the risk of scalding by lowering the temperature of hot sanitary water production output.
- Regulates the strong temperature variations equipment of hot sanitary water.
- Generates significant energy savings: much smaller heat losses in a loop at 55°C.
- Limit the scaling of pipes, valves, pumps, check valves, ... This thermostatic mixing valve provides comfort and safety to large flows facilities. Notably, the risk of scalds are removed (anti-scald safety). NB : The Δ T° Hot water/Mixed water must be minimum > 10°C and the maximum pressure difference between the inlets Hot water / Cold water should be 0.5 bar max.

Application

- Conditions where water is used at a predetermined temperature, stable: Chemical Industries - Slaughterhouses - Breweries ...
- Regulation of domestic water: Buildings - Hotels - Hospitals - Schools - Military barracks ...
- Collective showers for important facilities: Plants - Factories - Schools - Hospitals ...

Characteristic Curve

- Flanges PN16.
- Graduated handle 10 to 50°C or 30 to 70°C.

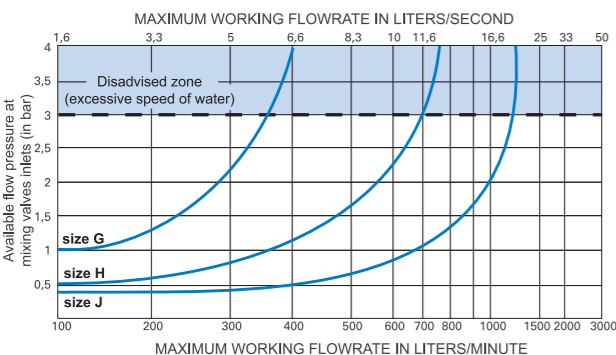

Flows:

Size	G	H	J	
Utilization flowrate:	l/min	360	700	1200
maximum	l/s	6	11,6	20
minimum	l/min	10	12	14

- Maximale static pressure: 10 bar.
- Maximale dynamic pressure: 6 bar.
- Recommended dynamic pressure for optimum regulation: 3-4 bar.

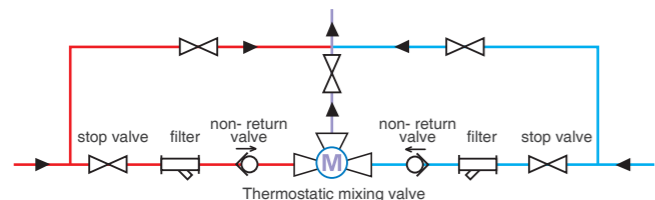

Installation Dimensions

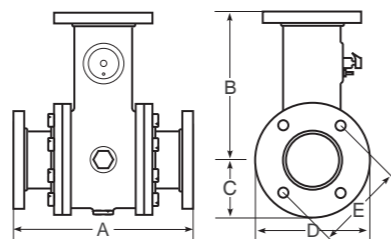

art. number	size	diameter	A (mm)	B (mm)	C (mm)	D (mm)	E (mm)	drilled flanges
22T70065	G	2"1/2 (65 mm)	294	215	90	185	145	4 holes
22T70080	H	3" (80 mm)	336	270	105	200	160	4 holes
22T70100	J	4" (100 mm)	404	270	125	220	180	8 holes

Spare parts:

designation	DN	art. number
distributor assembly (with 4 seals)	DN 65	22TB109786
distributor assembly (with 4 seals)	DN 80	22TB109787
distributor assembly (with 4 seals)	DN 100	22TB109787

designation	DN	art. number
bilame assembly	DN 65	22TB109327
bilame assembly	DN 80	22TB109328
bilame assembly	DN 100	22TB109329

designation	DN	art. number
setting screw assembly	DN 65	22TB109780
setting screw assembly	DN 80	22TB109781
setting screw assembly	DN 100	22TB109781

designation	DN	art. number
filter	DN 65	22TB109347
filter	DN 80	22TB109348
filter	DN 100	22TB109349

designation	DN	art. number
diaphragm (with 1 seal valve bottom)	DN 65	22TB109337
diaphragm (with 1 seal valve bottom)	DN 80	22TB109338
diaphragm (with 1 seal valve bottom)	DN 100	22TB109339

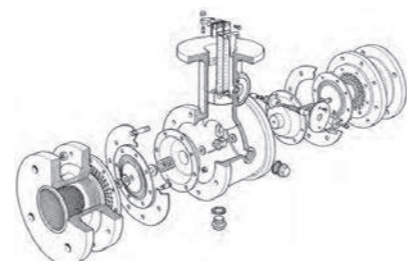

IntelliStation® Jr. EN-202208

IntelliStation® Jr.

Digital Water Mixing Valve

This appliance is recommended for all large flow applications where the mixed water temperature must be kept accurate, constant and modifiable at will.

Features

- Control water temperature ± 2°F in accordance with ASSE 1017
- Programmable set point range 60°F to 180°F for wide range of temperature
- Lead Free* construction to comply with lead free* installation requirement
- 3.5" full-color, user-selectable touch screen display
- High temperature Sanitization mode to address waterborne bacteria
- Integral check valves on hot and cold inlets to prevent cross flow
- In case of power failure, valve flows full cold for safety
- Configurable on location. Does not require factory pre-programming, lap top or special software
- Control module supports BAS (Building Automation System) communication with BACnet MSTP and Modbus protocols. It is native to the unit and does not require an add on module
- Mixed outlet temperature can be adjusted/monitored at the valve or remotely by BAS (Building Automation System) or Mobile and Web Apps
- Includes single operating sensor for a mixed outlet temperature reading
- Pass code protected for security
- Programmable hi/lo temperature alert
- Programmable schedule for setback of temperature
- On board clock for time stamping of error messages
- Wi-Fi enable for software upgrades, temperature monitoring, control and alerts
- Wi-Fi security protocols include WPA2-PSK and WPA2-PEAP-MSCHAPv2

Capacity

Model	Min System Draw+	Flow Capacity at 50-50 mixed ratio						
		Pressure Drop Across Valve						
	CV	5 psi 34 kpa	10 psi 69 kpa	20 psi 138 kpa	30 psi 207 kpa	45 psi 310 kpa	50 psi 345 kpa	
LFIS075VL	0.5	7.3	16 gpm 61 lpm	23 gpm 87 lpm	33 gpm 125 lpm	40 gpm 151 lpm	49 gpm 185 lpm	52 gpm 197 lpm
LFIS100VL	0.5	17.5	39 gpm 148 lpm	55 gpm 208 lpm	78 gpm 295 lpm	96 gpm 363 lpm	117 gpm 443 lpm	124 gpm 469 lpm
LFIS150VL	0.5	22.5	50 gpm 189 lpm	71 gpm 269 lpm	101 gpm 382 lpm	123 gpm 466 lpm	151 gpm 572 lpm	159 gpm 602 lpm
LFIS200VL	0.5	39.5	88 gpm 333 lpm	125 gpm 473 lpm	177 gpm 670 lpm	198 gpm 749 lpm	265 gpm 1003 lpm	279 gpm 1056 lpm

+ with a properly sized pump

Installation Dimensions

Model	Inlets	Outlet	A	B	C	D	E	F	G	H
LFIS075VL	3/4" (20 mm)	3/4" (20 mm)	4 7/8" (123 mm)	4 1/8" (103 mm)	4 5/8" (110 mm)	4 1/8" (103 mm)	2 9/16" (66 mm)	4 3/4" (120 mm)	4 5/8" (110 mm)	4 1/8" (105 mm)
LFIS100VL	1" (25 mm)	1 1/4" (32 mm)	5 3/8" (132 mm)	4 1/8" (120 mm)	4 3/4" (120 mm)	3 7/8" (99 mm)	2 9/16" (69 mm)	5 1/8" (130 mm)	5 5/8" (130 mm)	4 1/8" (120 mm)
LFIS150VL	1 1/2" (38 mm)	1 1/2" (38 mm)	5 3/8" (135 mm)	6 1/4" (159 mm)	5 1/8" (129 mm)	2 7/8" (54 mm)	4 1/2" (114 mm)	4 7/8" (124 mm)	5 3/8" (135 mm)	5 1/8" (147 mm)
LFIS200VL	2" (51 mm)	2" (51 mm)	5 7/8" (144 mm)	6 3/4" (169 mm)	5 7/8" (137 mm)	2 7/8" (54 mm)	4 1/2" (114 mm)	4 7/8" (124 mm)	5 3/8" (144 mm)	6 1/8" (158 mm)



LFIS150VL
Patent No. 10,823,296

Specifications

- Maximum Operating Pressure: 200psi (1379kPa)
- Maximum Hot Water Temperature: 200°F (93°C)
- Minimum Hot Water Supply Temperature** : 2°F (1°C) above set point
- Hot Water Inlet Temperature Range: 120-180°F (49-82°C)
- Cold Water Inlet Temperature: 39-80°F (4-26°C)
- Minimum Flow *** : 0.5gpm (1.89lpm)
- Temperature Adjustment Range**** : 60-180°F (16-82°C)
- Listing /Compliance: ASSE 1017, cUPC, NSF
- CSA 24/UL873, Bacnet Testing Laboratories (BTL), CE
- Weight: LFIS075VL 13lb (6kg)
LFIS100VL 17lb (8kg)
LFIS150VL 16lb (7kg)
LFIS200VL 19lb (9kg)
- Ambient Temperature: 32°F (0°C) to 122°F (50°C)
- Ambient Humidity: 0 - 90 RH non-condensing
- Power: 115-230 V (ac) ± 10%, 50/60 Hz, 20 VA
- Actuator Load: 24 V (dc), 0.55 A, 13 W

Approvals



Valve Only Controller Only

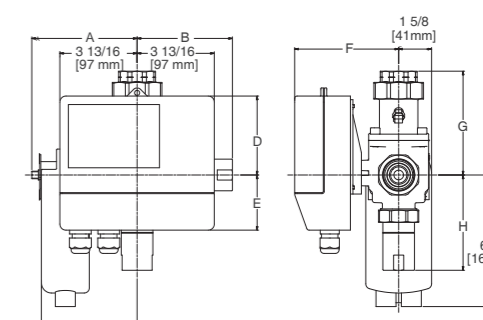

Ordering Code

Valve	Inlets (in)	Outlet (in)	Order Code
LFIS075VL	3/4"	3/4"	LFIS075VL
LFIS100VL	1"	1 1/4"	LFIS100VL
LFIS150VL	1 1/2"	1 1/2"	LFIS150VL
LFIS200VL	2"	2"	LFIS200VL



IntelliStation® EN-202208

IntelliStation®

Digital Water Tempering and Recirculating System

Capacity up to 858 gpm @ 45psi

Features

- Configurable on location. Does not require factory preprogramming or special software and laptop
- Controls water temperature to +/- 2°F in accordance with ASSE 1017
- Control +/- 2°F during periods of low/zero demand
- 3.5" full-color, user-selectable touch screen display
- User programmable high-temperature sanitization mode
- In case of power or cold water failure, valve flows full cold for safety with manual override feature to set mixed outlet temperature
- Settings can be adjusted/monitored at the controller or remotely through BAS (Building Automation System)
- Displays pressure, temperature and flow/BTU data
- Pass code protected for security
- User programmable high temperature alarm

Specifications

- Maximum Operating Pressure: 200psi (1379kPa)
- Maximum Hot Water Temperature: 200°F (93°C)
- Minimum Hot Water Supply Temperature**: 2°F (1°C) above set point
- Hot Water Inlet Temperature Range: 120-180°F (49-82°C)
- Cold Water Inlet Range: 39-80°F (4-27°C)
- Minimum Flow ***: 0.5gpm (1.89lpm)
- Temperature Adjustment Range****: 80-180°F (27-82°C)
- Power: 115/230V (ac) ±10%
50/60HZ, 30VA, 1180VA fully loaded
- Listing /Compliance: ASSE 1017^, cUPCA, NSF^, CSA 24/UL873, Bacnet Testing Laboratories (BTL)
- Ambient Temperature: 32°F (0°C) to 104°F (40°C)
- Ambient Humidity: 0 - 90 RH non-condensing
- Pump relay: 16A @ 250 VAC
- Alert relay: 5A @ 250 VAC, 5A @ 30 VDC

Approvals



Capacity

Model	Min. System Draw+	CV	Flow Capacity at 50-50 Mixed Ratio					
			Pressure Drop Across Valve					
			5psi (34 kPa)	10psi (69 kPa)	20psi (138 kPa)	30psi (207 kPa)	45psi (310 kPa)	50psi (345 kPa)
LFIS150	0.5	26.88	60 gpm 227 lpm	85 gpm 322 lpm	120 gpm 454 lpm	147 gpm 556 lpm	180 gpm 681 lpm	190 gpm 719 lpm
LFIS200	0.5	42.70	96 gpm 363 lpm	135 gpm 511 lpm	191 gpm 723 lpm	234 gpm 886 lpm	286 gpm 1083 lpm	302 gpm 1143 lpm
LFIS150DV	0.5	53.57	120 gpm 454 lpm	170 gpm 644 lpm	240 gpm 908 lpm	294 gpm 1113 lpm	360 gpm 1363 lpm	380 gpm 1439 lpm
LFIS200DV	0.5	85.27	192 gpm 727 lpm	270 gpm 1022 lpm	382 gpm 1446 lpm	468 gpm 1772 lpm	572 gpm 2165 lpm	604 gpm 2286 lpm
LFIS200TV	0.5	127.90	288 gpm 1090 lpm	405 gpm 1533 lpm	573 gpm 2169 lpm	702 gpm 2657 lpm	858 gpm 3248 lpm	906 gpm 3430 lpm



Single Valve IntelliStation

NOTICE

- * The wetted surface of this product contacted by consumable water contains less than 0.25% of lead by weight.
- ** With equal pressure
- *** Minimum flow when IntelliStation is installed at or near hot water source recirculating tempered water with a properly sized continuously operating recirculating pump.
- **** Low limit cannot be less than the cold water temperature.
- ^ Listed without pump



IntelliStation® EN-202208

Dual Valve IntelliStation

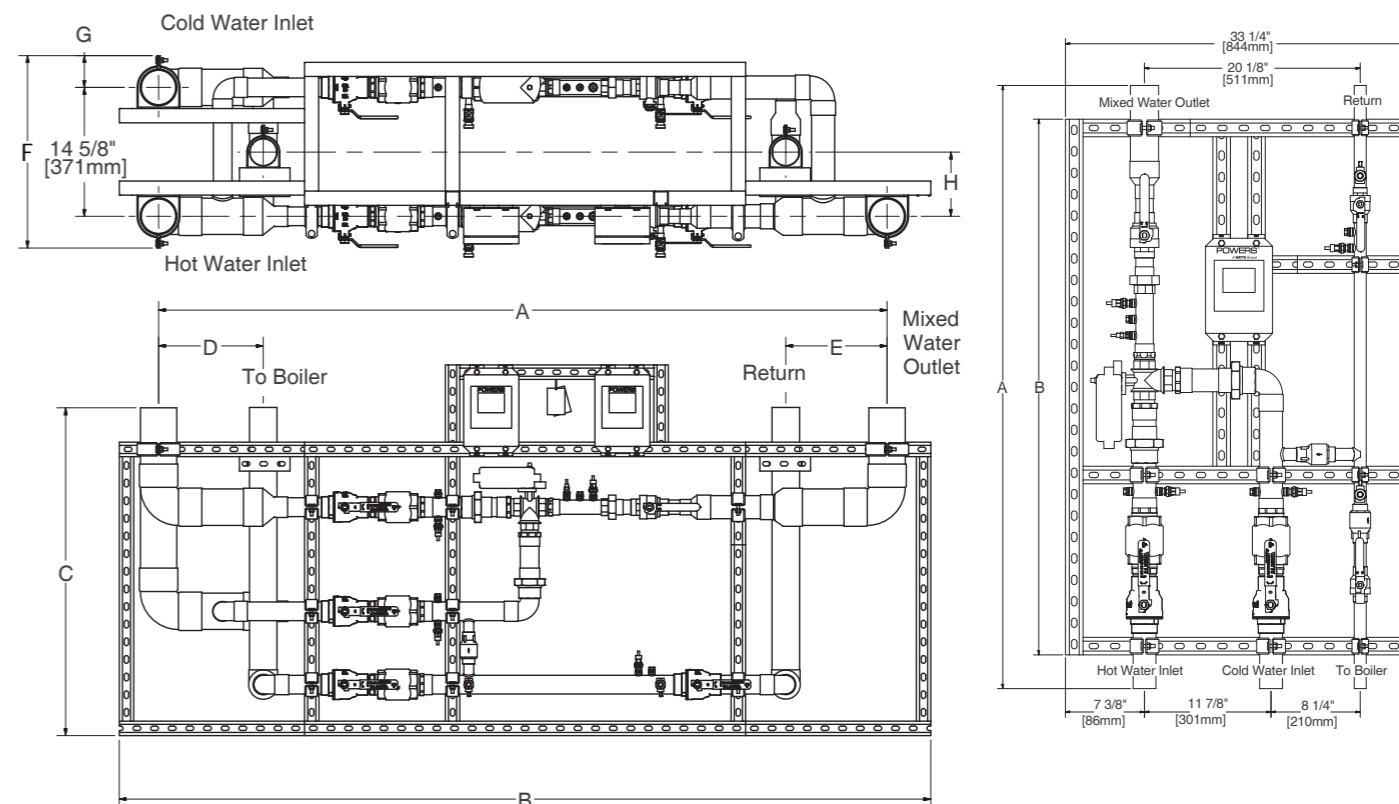

Triple Valve IntelliStation

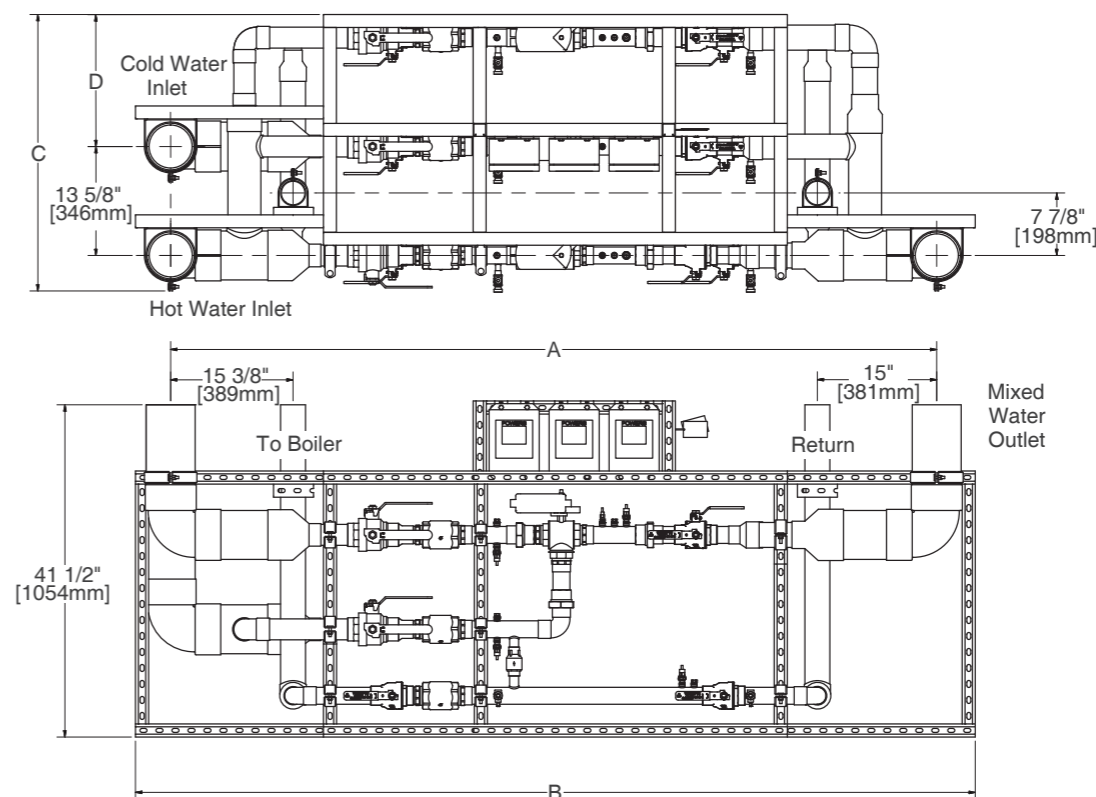

Dimensions are shown ±1/2"

Single Valve

Model	Inlets	Outlet	Return	A	B
LFIS150C00LP	2" (50mm)	2½" (63mm)	1" (25mm)	56¾" (1431mm)	50" (1270mm)
LFIS150C0SLP+	2" (50mm)	2½" (63mm)	1" (25mm)	56¾" (1431mm)	50" (1270mm)
LFIS150CF0LP	2" (50mm)	2½" (63mm)	1" (25mm)	78¼" (1988mm)	72" (1829mm)
LFIS150CFSLP+	2" (50mm)	2½" (63mm)	1" (25mm)	78¼" (1988mm)	72" (1829mm)
LFIS150F00LP	2" (50mm)	2½" (63mm)	2" (50mm)	56¾" (1431mm)	50" (1270mm)
LFIS150F0SLP+	2" (50mm)	2½" (63mm)	2" (50mm)	56¾" (1431mm)	50" (1270mm)
LFIS150FF0LP	2" (50mm)	2½" (63mm)	2" (50mm)	78¼" (1988mm)	72" (1829mm)
LFIS150FFSLP+	2" (50mm)	2½" (63mm)	2" (50mm)	78¼" (1988mm)	72" (1829mm)
LFIS200C00LP	2½" (63mm)	3" (75mm)	1" (25mm)	63¾" (1615mm)	57" (1448mm)
LFIS200C0SLP+	2½" (63mm)	3" (75mm)	1" (25mm)	63¾" (1615mm)	57" (1448mm)
LFIS200CF0LP	2½" (63mm)	3" (75mm)	1" (25mm)	80¾" (2038mm)	74" (1880mm)
LFIS200CFSLP+	2½" (63mm)	3" (75mm)	1" (25mm)	80¾" (2038mm)	74" (1880mm)
LFIS200F00LP	2½" (63mm)	3" (75mm)	2" (50mm)	63¾" (1615mm)	57" (1448mm)
LFIS200F0SLP+	2½" (63mm)	3" (75mm)	2" (50mm)	63¾" (1615mm)	57" (1448mm)
LFIS200FF0LP	2½" (63mm)	3" (75mm)	2" (50mm)	80¾" (2038mm)	74" (1880mm)
LFIS200FFSLP+	2½" (63mm)	3" (75mm)	2" (50mm)	80¾" (2038mm)	74" (1880mm)

+Strainers ship loose and must be installed by a plumber at the job site

Dual Valve

Model	Inlets	Outlet	Return	A	B	C	D	E	F	G	H
LFIS150DVH00LP	4" (100mm)	4" (100mm)	3" (75mm)	82½" (2099mm)	92" (2337mm)	37½" (943mm)	11½" (301mm)	11½" (292mm)	21¾" (555mm)	3½" (92mm)	7¼" (184mm)
LFIS150DVH0SLP	4" (100mm)	4" (100mm)	3" (75mm)	90½" (2302mm)	100" (2540mm)	37½" (943mm)	11½" (301mm)	11½" (292mm)	21¾" (555mm)	3½" (92mm)	¼" (184mm)
LFIS150DVHF0LP	4" (100mm)	4" (100mm)	3" (75mm)	104¾" (2651mm)	113¼" (2889mm)	37½" (943mm)	11½" (301mm)	11½" (292mm)	21¾" (555mm)	3½" (92mm)	7¼" (184mm)
LFIS150DVHFSLP	4" (100mm)	4" (100mm)	3" (75mm)	112¾" (2854mm)	12¼" (3092mm)	37½" (943mm)	11½" (301mm)	11½" (292mm)	21¾" (555mm)	3½" (92mm)	7¼" (184mm)
LFIS200DVH00LP	6" (150mm)	6" (150mm)	3" (75mm)	91¾" (2330mm)	100" (2540mm)	41¾" (1060mm)	13" (330mm)	13½" (344mm)	23½" (597mm)	4½" (114mm)	7¾" (187mm)
LFIS200DVH0SLP	6" (150mm)	6" (150mm)	3" (75mm)	103" (2616mm)	111¼" (2838mm)	41¾" (1060mm)	13" (330mm)	13½" (344mm)	23½" (597mm)	4½" (114mm)	7¾" (187mm)
LFIS200DVHF0LP	6" (150mm)	6" (150mm)	3" (75mm)	107¾" (2737mm)	116" (2946mm)	41¾" (1060mm)	13" (330mm)	13½" (344mm)	23½" (597mm)	4½" (114mm)	7¾" (187mm)
LFIS200DVHFSLP	6" (150mm)	6" (150mm)	3" (75mm)	121¾" (3083mm)	130" (3302mm)	41¾" (1060mm)	13" (330mm)	13½" (344mm)	23½" (597mm)	4½" (114mm)	7¾" (187mm)

Triple Valve

Model	Inlets	Outlet	Return	A	B	C	D
LFIS200TVH00LP	6" (150mm)	6" (150mm)	3" (75mm)	95¾" (2432mm)	105" (2667mm)	36¼" (921mm)	18½" (460mm)
LFIS200TVH0SLP	6" (150mm)	6" (150mm)	3" (75mm)	107" (2718mm)	116¼" (2953mm)	36¼" (921mm)	18½" (460mm)
LFIS200TVHF0LP	6" (150mm)	6" (150mm)	3" (75mm)	111¾" (2838mm)	121" (3073mm)	36¼" (921mm)	18½" (460mm)
LFIS200TVHFSLP	6" (150mm)	6" (150mm)	3" (75mm)	123¾" (2143mm)	133" (3143mm)	36¼" (921mm)	18½" (460mm)

Series LF174A

ASME Water Pressure Relief Valve

Size: DN20 – DN50

Lead Free cast copper silicon alloy body safety relief valves for pressure protection only of all types of hot water heating boiler equipment. Pressure range 50 to 150psi (3 - 10 bar) with corresponding high ratings from 950,000 to 14,370,000 BTU/hr. Female inlet and outlet connections. The LF174A features Lead Free* construction to comply with Lead Free* installation requirements.

Features

- Seat located above drain; water can't be trapped and sediment can't foul seat
- Non-mechanical seat-to-disc alignment will not stick or freeze
- Water seal of high temperature resisting material isolates spring working parts from water during relief

Pressure-Temperature

- Standard Set Pressure Range: 30 – 150 psi
- Temperature Range: 0.5 °C ~121 °C

Material

Component	Material
Body	Cast Copper Silicon Alloy
Spring	Stainless Steel
Disc	Non-metallic
Seat	Metal

Installation Dimensions

Model	Size	Model	Length		Height		Weight	
			in.	mm	in.	mm	lbs.	kg.
LF174A	¾ x ¾	M3	4 1/2	116	2 3/4	67	1.2	0.5
LF174A	1 x 1	M1	5 3/4	144	3	76	1.9	0.9
LF174A	1¼ x 1¼	M1	8 1/2	213	4 1/4	109	4.6	2.1
LF174A	1½ x 1½	M	9 1/4	232	4 3/4	122	6.9	3.1
LF174A	2 x 2	M	11 1/2	290	6 1/2	162	14.4	6.6



Specification

- Design Standard: MIL-V-18634B, Type I
- Connection Standard: ASME B1.20.3
- Test Standard: NSF 372, ASME section IV
- Note: For installation, maintenance, operation, and inspection guides, please refer to specification sheet on Watts website: www.watts.com

Approvals



Characteristic Chart

BTU/hr Steam Pressure Discharge Capacities
As tested and rated by the National Board of Boiler and Pressure Vessel Inspectors

Series 174A						
Set	¾" x ¾"	1" x 1"	1¼" x 1¼"	1½" x 1½"	2" x 2"	
50	3.45	950,000	1,470,000	2,459,000	2,950,000	5,575,000
55	3.79	1,025,000	1,590,000	2,653,000	3,190,000	6,010,000
60	4.13	1,100,000	1,702,000	2,847,000	3,425,000	6,450,000
65	4.58	1,170,000	1,820,000	3,041,000	3,660,000	6,890,000
70	4.82	1,245,000	1,935,000	3,325,000	3,890,000	7,330,000
75	5.17	1,320,000	2,055,000	3,429,000	4,125,000	7,770,000
80	5.51	1,400,000	2,166,000	3,605,000	4,360,000	8,215,000
85	5.86	1,470,000	2,285,000	3,817,000	4,590,000	8,650,000
90	6.6	1,545,000	2,400,000	4,011,000	4,825,000	9,090,000
95	6.55	1,620,000	2,520,000	4,205,000	5,060,000	9,530,000
100	6.89	1,695,000	2,635,000	4,399,000	5,290,000	9,970,000
105	7.23	1,770,000	2,750,000	4,593,000	5,525,000	10,410,000
110	7.58	1,845,000	2,865,000	4,787,000	5,760,000	10,850,000
115	7.92	1,920,000	2,980,000	4,981,000	5,990,000	11,290,000
120	8.27	1,995,000	3,100,000	5,175,000	6,225,000	11,730,000
125	8.61	2,070,000	3,215,000	5,370,000	6,460,000	12,170,000
130	8.96	2,145,000	3,330,000	5,564,000	6,690,000	12,610,000
135	9.3	2,220,000	3,445,000	5,758,000	6,925,000	13,050,000
140	9.65	2,295,000	3,565,000	5,952,000	7,160,000	13,490,000
145	9.99	2,370,000	3,680,000	6,146,000	7,390,000	13,930,000
150	10.34	2,445,000	3,795,000	6,340,000	7,630,000	14,370,000



LF530C-EN-201910

Series LF530C

Pressure Relief Valve

Size: DN15 – DN20

Watts Series LF530C Pressure Relief Valves are spring operated Lead Free brass relief valves designed to be used only as protection from the buildup of excessive pressure in systems containing water, oil or air. These valves are not ASME approved safety relief valves and should not be used in system applications with this requirement. They feature a Lead Free brass construction with stainless steel springs. Ideally suited as a bypass thermal expansion relief valve, the Series LF530C valves incorporate a calibrated adjustment feature for setting the valve to the relief pressure required.

Features

- Lead free brass
- Stainless steel spring
- Calibrated adjustment feature
- Protects against buildup of excessive pressure
- For use in systems containing water, oil, air

Pressure-Temperature

- Maximum Pressure: 300 psi (20.67 bar)
- Standard Set Pressure Range: 50 – 175 psi
- Temperature Range: 0.5 °C ~82 °C

Material

Component	Material
Body	Lead Free*brass
Springs	Stainless Steel
Disc	BUNA-N
Seat	Lead Free Brass

Installation Dimensions

Model	Size	Dimensions		Weight			
		Height	Width	lbs	gms		
	in	in	mm	in	mm	lbs	gms
LF530C	1 3/4	3	76	1 5/8	45	5/8	284



Specification

- Design Standard: ANSI Z21.22
- Connection Type: ASME B1.20.3
- Test Standard: NSF 372
- Note: For installation, maintenance, operation, and inspection guides, please refer to specification sheet on Watts website: www.watts.com

Characteristic Curve

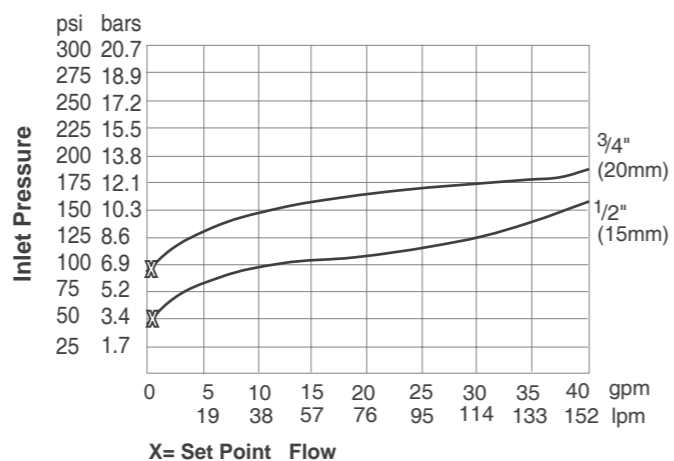

LFN36-M1-EN-202206

Series LFN36-M1

Vacuum Relief Valve

Size: DN15 – DN20

Features

- Low profile
- All Lead Free brass body
- Protective cap
- Suitable for low pressure steam and water service

Pressure-Temperature

- Nominal Pressure: 200psi (13.8 bar)
- Maximum Temperature: 121 °C

Material

Component	Material
Body	Lead Free*Brass Components
Cover	Polypropylene
Disc	Silicone
Springs	302 Stainless Steel
O-ring	Buna-N
Float	Glass Filled Polysulfone

Installation Dimensions

Size	Dimensions		Weight		Venting Capacity	
	A	B	oz	gr	CFM	LPM
1/2	2	50	4	113	15	425
3/4	2	50	4	113	15	425

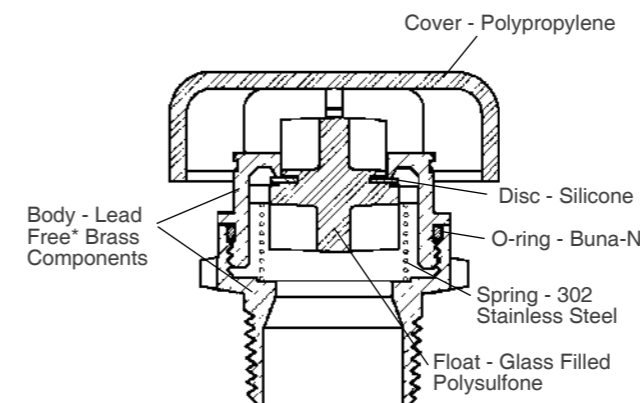

Specification

- Design Standard: ANSI Z21.22
- Connection Standard: ASME B1.20.3
- Test Standard: NSF 372, ANSI Z21.22
- Note: For installation, maintenance, operation, and inspection guides, please refer to specification sheet on Watts website: www.watts.com

Approval

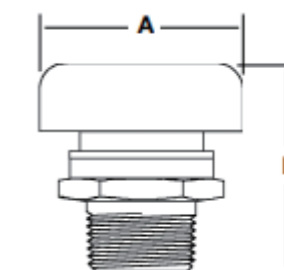



1XL/100XL-EN-201910

Series 1XL/100XL

Temperature and Pressure Relief Valve

Size: DN15 - DN20

The combined 2 in 1 T&P relief valve provides the least expensive and proven means for protection against both excessive temperature and pressure emergency conditions.

Features

- Features a unique thermostat with special thermostatically bonded coating
- Thermostat is accurate and proven. Exclusively designed and manufactured by Watts

Pressure-Temperature

- Standard Set Pressure: 75, 100, 125, 150 psi
- Maximum Operating Pressure: must not exceed 75% of set pressure
- Temperature Range: 0.5 °C ~71 °C

Material

Component	Material	Standard
Lever	Steel	UNS G10100 (C1010)
Lever Pin	Steel	UNS G10060 or UNS G10080
Spring	Stainless Steel	
Spring Guide	Brass	ASTM B16
Pull Rod	Brass	UNS C36000, ASTM B16
Washer	Zinc Plated	SAE 1008
Disc	Silicone	
Disc Holder	Brass	UNS C26000
Disc Rivet	Brass	UNS C36000, ASTM B16
Body	Bronze(1XL) Brass(100XL)	ASTM B584 UNS NO, C84400 ASTM B16
Thermostat Body	Copper	ASTM B75 UNS C12200
Gasket	Buna-N	DURO 60
Guide Busng	Brass	UNS C26000
Adjusting Cap	Stainless Steel	UNS S30200

Installation Dimensions

Model	Size		Dimensions								Csa		
	in.	mm	A		B		D		Weight		Temp.	Steam Rating	
1L2 M7	1/2	15	1 3/4	43	3 1/2	89	7/8	22	2	50	10	284	5,000
1XL-4 M7	1/2	15	1 3/4	43	3 1/2	89	7/8	22	4	100	12	340	15,000
1XL-8 M7	1/2	15	1 3/4	43	3 1/2	89	7/8	22	8	203	16	454	15,000
10L-2 M7	3/4	20	1 5/32	40	3 11/64	91	1 3/16	30	2	50	8	227	80000
100XL-4 M7	3/4	20	1 5/32	40	3 11/64	91	1 3/16	30	4	100	8	227	105,000
100XL-8 M7	3/4	20	1 5/32	40	3 11/64	91	1 3/16	30	8	203	8	227	105,000



Specification

- Design Standard: ANSI Z21.22
- Connection Standard: ASME B1.20.3
- Test Standard: ANSI Z21.22, ASME Section IV
- Note: For installation, maintenance, operation, and inspection guides, please refer to specification sheet on Watts website: www.watts.com

Approval

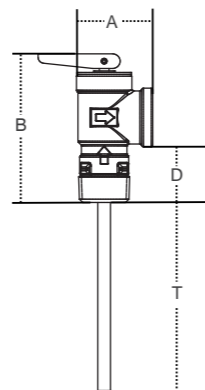

FP53L-EN-202208

Model FP53L

Pressure Relief Valve

Size: DN15

Watts No. FP53L is designed for use in fire protection grid systems to provide protection against excessive water pressure caused by thermal expansion or line surge. It is available in 175psi (12.1 bar), pressure relief settings and can be installed horizontally or vertically. Bronze body construction with stainless steel spring to inhibit corrosion. The valve is constructed with a precision stem guide to ensure proper reseating. The test lever affords periodic manual testing and flushing of waterways and seating surfaces.

Features

- Underwriters Laboratory listed
- Forged stainless steel spring
- Bronze body construction for superior strength and to prevent corrosion
- Manual test lever
- Valve stem is guided to enhance reseating
- 1/2" male inlet x female outlet
- Pressure settings: 175psi (12.1 bar)

Pressure - Temperature

- Nominal Pressure: PN16
- Temperature Range: -20°C ~110°C

Specification

For applications requiring a UL approved relief valve to provide pressure relief protection from water pressure in excess of 175psi (12.1 bar). Each valve shall be bronze body construction with forged stainless steel spring. It shall have a test lever and the valve shall be guided to enhance reseating and to decrease chance of the seat being misaligned. Watts Model No. FP53L.

Installation Dimensions

MODEL	SIZE	HEIGHT	WIDTH	WEIGHT
	in.	mm	mm	kgs.
FP53L	1/2"	89	48	.23



1/2" NPT
Female Outlet

1/2" NPT
Male Inlet

Approval





R1001/R1001N-EN-202112

Series R1001/R1001N

Brass Float Valves

Size: DN15-DN100

The Watts R1001/R1001N series Float Valves are used in commercial, industrial, and agricultural applications for controlling water flow.

Features

- Heavy duty float valves
- Pipe-threaded for pipe connections and straight-pipe threaded for locknut
- No jam single lever action
- Ball float options - plastic & copper

Pressure - Temperature

- Nominal Pressure: PN16(DN15-65)
PN14(DN80-DN100)
- Temperature Range: -20°C~110°C

Material

NO.	Component	Material	Standard
1	Body	Brass	CW617N
2	Seal	EPDM	
3	Arm	Stainless Steel	SUS304

Installation Dimensions

Size DN(mm)	Dimensions(mm)			
	A	B	C	E
15	1/2"	73	30	M8
20	3/4"	75	30	M8
25	1"	84	36	M8
32	1-1/4"	126	50	M10
40	1-1/2"	131	50	M10
50	2"	131	50	M12
65	2-1/2"	143	50	M12
80	3"	152	50	M14
100	4"	169	50	M14

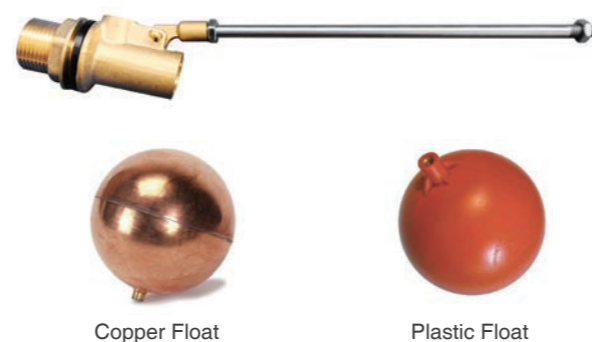

Specification

- Connection Standard: ISO 228-1
- Medium: water

Approval

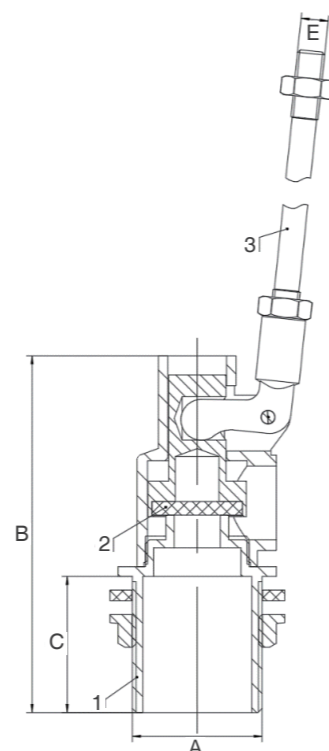

DETA-EN-202203

Series DETA

Pressurized Expansion Tanks for Potable Hot Water

Watts Model DETA Tanks are ASME fixed bladder type pre-charged expansion tanks for commercial and industrial fresh potable hot water applications. They are designed to accept the expanded volume of hot water keeping the system pressure below the relief valve setting. The water is contained in a butyl bladder.

Features

- ASME section VIII construction
- Fixed Butyl Bladder (FDA approved)
- Stainless steel system connection
- Pre-charged to 40 psi (2.7 bar) (field adjustable)

Test Pressure

Pneumatic
195 psi

Installation Dimension

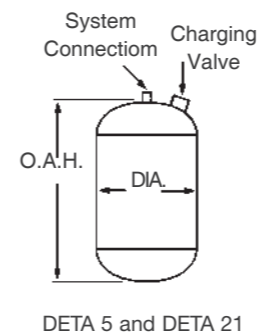

Specification

- Design Standard: constructed in accordance with Section VIII of the ASME Boiler and Pressure Vessel Code.
- Connection Type: NPT
- Note: Tanks are factory pre-charged at 40 psi and field adjustable. Lift ring on models DETA42 through DETA210.

Pressure-Temperature

- Nominal Pressure: 150 psi (10 bar)
- Maximum Temperature: 115°C

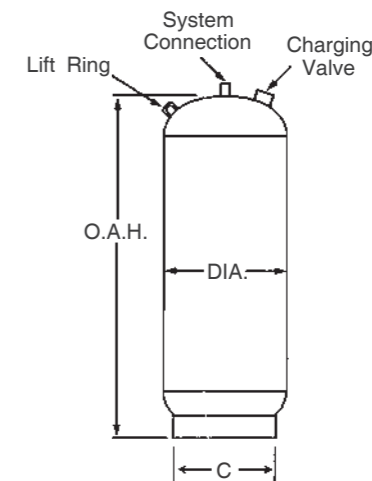

DETA 20 through DETA 210

Model Number	System Connection DN		Max. Operating Pressure (PSIG)	Dia		Dimensions				Weight*		Tank Volume Gallons	Acceptance Volume Gallons
	in.	mm		in.	mm	Height	C		in.	mm	lbs.		
DETA 5	3/4	20	150	10	254	14	356	-	-	22	10	3.5	2.3
DETA 12	3/4	20	150	12	305	14	356	-	-	28	13	5	3.3
DETA 20	3/4	20	150	12	305	20	508	10	254	34	15	8	5.3
DETA 30	1	25	150	16	406	24	609	14	356	64	29	15	10.0
DETA 42	1	25	150	16	406	31	788	14	356	88	40	22	14.5
DETA 60	1	25	150	16	406	34	864	14	356	93	42	26	17.5
DETA 80	1	25	150	16	406	45	1143	14	356	109	49	35	23.5
DETA 100	1	25	150	20	508	39	990	18	457	148	67	45	30
DETA 125	1 1/2	40	150	24	610	47	1701	22	457	259	117	70	47
DETA 150	1 1/2	40	150	24	610	50	1270	22	559	268	122	80	53



PLT-EN-202203

Series PLT

Portable Water Expansion Tanks

Series PLT Potable Water Expansion Tanks are designed to absorb the increased volume of water created by thermal expansion and to maintain balanced pressure throughout the potable water supply system. Heated water expands, and in a domestic hot water system, the system may be closed when the potable water system is isolated from the public water supply by a one-way valve such as pressure reducing valve, backflow preventer or check valve. Provisions must be made for this expansion.

Features

- Rugged flexible butyl diaphragm
- Field adjustable pre-charge
- In-line and free standing models
- Can be used with most standard hot water heaters and storage tanks

Pressure-Temperature

- Nominal Pressure: 150 psi
- Maximum Temperature: 93°C

Test Pressure

Pneumatic
100 psi

Installation Dimensions

Description	PLT-5	PLT-12	PLT-20	PLT-35
Max. Pressure - PSI	150	150	150	150
Max. Temp. - °F	200	200	200	200
Tank Volume - Gal.	2.1	4.5	8.5	14.00
Air Pre-charge - PSI	20	20	20	20
Connections Size - Inches	3/4 Male	3/4 Male	3/4 Male	1 Female
Diameter - Inches	8	10.5	12.5	16.0
Length - Inches	11	13.5	19.2	21.7
Weight - Lbs.	5.5	10	15	32

Characteristic Chart

SUPPLY PRESSURE (PSIG)	WATER HEATER (GALLONS)						
	20	30	40	50	80	100	120
40							
50							
55							
60							
70							
80							
90							
100							
110							
120							

- PLT-5
- PLT-12
- PLT-20
- PLT-35
- Multiple tanks required - consult factory



Specification

- Design Standard: IAPMO
- Note: The potable water expansion tank shall be installed in the cold water service pipe line on the supply side of the water heater (or water storage tank). A pressure relief valve sized and installed in accordance with local codes must be incorporated in the system.

Material

Component	Material
Diaphragm	Butyl rubber
Inlet Connection	Stainless Steel

Approvals



Air Side Pre-pressure (PSI)	Water Side Volume at 150PSI (Gallons)			
	PLT-5	PLT-12	PLT-20	PLT-35
20	1.48	3.42	7.102	10.69
40	1.26	2.88	5.882	9.17
60	1.0	2.49	4.705	7.59
80	0.8	1.85	4.009	6.07



ETX-EN-202208

Series ETX, ETSX

Pressurized Expansion Tanks for Heating and Cooling Systems

Size: DN15-DN20

Series ETX and ETSX Pressurized Expansion Tanks for Heating and Cooling Systems are designed to absorb the increased volume of water created when water is heated. These tanks maintain system pressure below the relief setting of the relief valve. The Series ETX and ETSX's pre-pressurized steel tank features a durable expansion membrane that prevents contact of the water with the air in the tank. This rugged diaphragm minimizes loss of the air change and ensures long and trouble-free life for the system.

Features

- Precharged at 12psi (83 kPa)
- Rugged flexible butyl diaphragm
- In-line and free standing models
- Compatible with glycol in systems
- Steel construction

Models

- ETX Mounts to supply piping
- ETSX Free standing

Material

Component	Material
Diaphragm	Butyl rubber
Outer Shell	Carbon Steel with Epoxy finish

Installation Dimensions

MODEL	TANK VOL. gal.	ACCEPT. VOL. @ 12psi	CONNECTION	DIAMETER		HEIGHT		WEIGHT	
				in mm.	in mm.	lbs.	kgs.		
ETX-15	2.1	1.0	1/2" MNPT	8 203	12 1/2 318	5.0	2.3		
ETX-30	4.5	2.5	1/2" MNPT	11 279	14 356	10.0	4.54		
ETX-60	6.0	3.0	1/2" MNPT	11 3/8 290	17 3/16 437	11.5	5.22		
ETX-90	15.0	6.0	3/4" MNPT	16 406	20 3/16 528	28.0	12.70		
ETSX-30	15.0	6.0	1" FNPT	16 406	21 11/16 551	32.0	14.51		
ETSX-40	20.0	8.0	1" FNPT	16 406	28 3/16 732	39.0	17.69		
ETSX-60	33.0	13.3	1" FNPT	16 406	42 3/16 1087	57.0	28.85		
ETSX-90	44.0	17.7	1 1/4" FNPT	21 533	36 3/16 919	72.0	32.66		
ETSX-110	62.0	24.9	1 1/4" FNPT	21 533	47 7/8 1217	112.0	50.80		
ETSX-160	81.0	32.6	1 1/4" FNPT	21 533	62 1575	123.0	55.79		

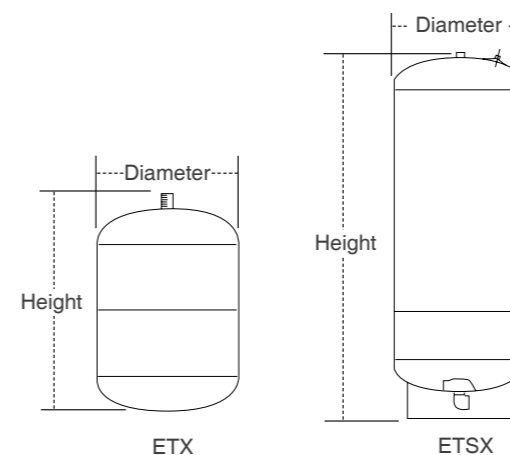

ETX



Specification

Furnish and install as shown on plans a Watts Model ETX/ETSX _____ gallon _____ " diameter x _____ " (high) pre-charged steel expansion tank with a fixed butyl bladder. The tank shall have an NPT system connection and a .302"-32 charging valve connection (standard tire valve) to facilitate the on-site charging of the tank to meet system requirements. The tank shall be factory pre-charged to 12psi. The tank shall be a Watts Series ETX or ETSX.

Ratings

- Maximum Working Temperature: 220°F (104°C)
- Maximum Working Pressure:
 - ETX-15, ETX-30, ETX-60: 75psi (517 kPa)
 - ETX-90 and ETSX Series: 100psi (6.9 bar)
- Precharge (field adjustable): 12psi (83 kPa)

Balancing Valves

- Motorized Valves
- Static Balancing Valve
- Differential Pressure Control Valve
- Pressure Independent Control Valve
- Intelligent Control Valve
- Metering Station
- Flow Switch
- Triple Duty Valve
- Suction Diffuser
- Test Points

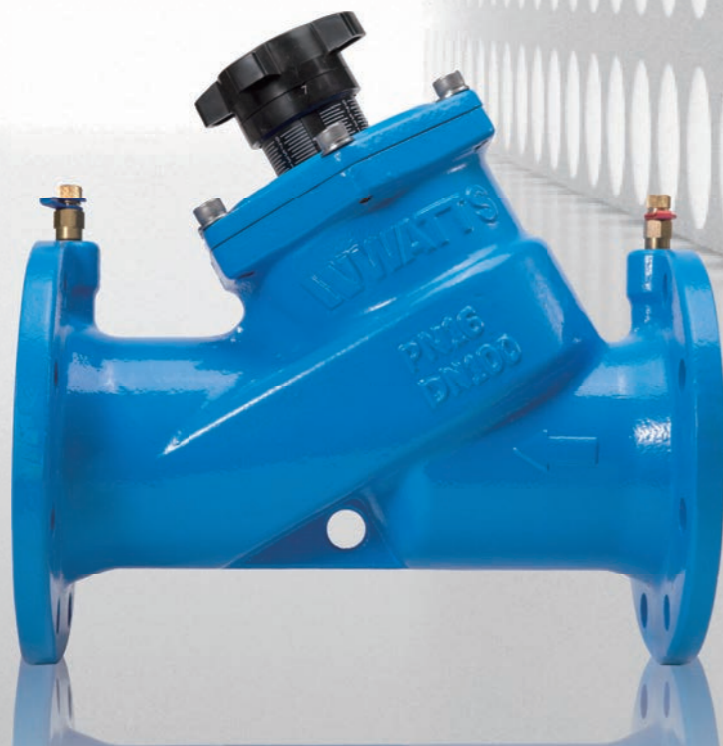

W-W1111-EK/ET-EN-202212

Series W-W1111-EK/ET

On-off/Regulating Electric Butterfly Valve

Size: DN50-DN600

The Watts Series W-W1111 Electric butterfly valves are designed and manufactured to meet the stringent requirements of plumbing, HVAC, irrigation, commercial and industrial application.

Features

- Simple structure, easy to operate
- Simple installation, excellent sealing performance
- High reliability and long durability
- Good compatibility
- The good sealing effect, with no pin and no backrest

Pressure - Temperature

- Nominal Pressure: PN16
- Temperature Range: -15°C ~ 120°C

Test Pressures

Shell: 24 bar
Seat: 17.6 bar

Material

Component	Material
Body	Ductile Iron
Disc	Stainless Steel
	Aluminum Bronze
	Ductile Iron(Nickel-plated)
	Ductile Iron(Epoxy coated)
Seat	EPDM
Stem	Stainless Steel



Specification

- Design Standards: EN 593, BS 5155, MSS SP-67
- Connection Standard: ISO7005-2:1998
BS EN1092-2:1997
- Connection Type: Wafer Type
- Medium: water

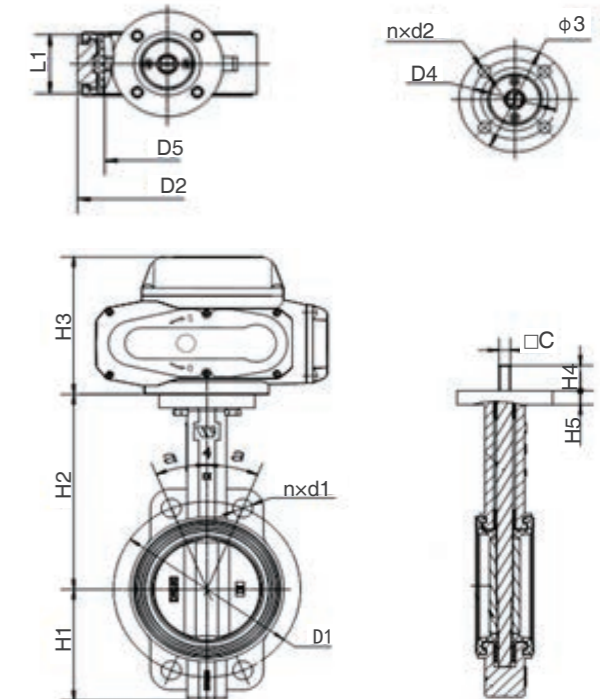

Installation Dimensions

DN	H1	H2	H3	H4	L1	C/φ C	D1	nxd1	α	D2	D5	D4	n x φ d2	φ 3	H5	Torque(N.m)	
																Wet	Dry
50	62	136	144	24	43	9	φ 125	4X φ 19	45°	φ 89	φ 51.7	φ 70	4X φ 10	φ 92	12	15.1	24.2
65	70	145	144	24	46	9	φ 145	4X φ 19	45°	φ 105	φ 63.3	φ 70	4X φ 10	φ 92	13	17.2	32.7
80	89	151	144	24	46	9	φ 160	4X φ 19	22.5°	φ 120	φ 77.7	φ 70	4X φ 10	φ 92	14	23.1	43.7
100	106	170	144	26	52	11	φ 180	4X φ 19	22.5°	φ 148	φ 103.1	φ 70	4X φ 10	φ 92	14	39.8	72.8
125	119	190	167	26	56	14	φ 210	4X φ 19	22.5°	φ 170	φ 122.2	φ 70	4X φ 10	φ 92	14	61.9	108
150	131	203	167	26	56	14	φ 240	4X φ 23	22.5°	φ 203	φ 154.9	φ 70	4X φ 10	φ 92	14	102	174
200	164	245.5	201	33	60	17	φ 295	4X φ 23	15°	φ 255	φ 201.3	φ 102	4X φ 12	φ 125	14	192	330
250	199	271	201	26	68	22	φ 355	4X φ 28	15°	φ 303	φ 249.4	φ 102	4X φ 12	φ 125	14	323	549
300	230	296	201	26	78	22	φ 410	4X φ 28	15°	φ 355	φ 300.1	φ 102	4X φ 12	φ 140	19	490	799
350	288	368	251	40	78	φ 31.6	φ 470	4X φ 28	11.25°	φ 436	φ 331.5	φ 102	4X φ 14	φ 140	20	625	969
400	331	400	251	52	102	φ 33.15	φ 525	4X φ 31	11.25°	φ 488	φ 387.5	φ 140	4X φ 18	φ 175	20	846	1307
450	355	422	251	52	114	φ 38	φ 585	4X φ 31	9°	φ 536	φ 438.5	φ 140	4X φ 18	φ 175	20	1131	1787
500	388	480	309	64	127	φ 41.15	φ 650	4X φ 34	9°	φ 593	φ 488.8	φ 140	4X φ 18	φ 175	22	1431	2288
600	475	562	309	70	154	φ 50.65	φ 770	20X φ 37	9°	φ 820	φ 589.9	φ 165	4X φ 22	φ 210	22	2301	3711

Watts reserves the right to change or modify product design, construction, specifications, or materials without prior notice and without incurring any obligation to make such changes and modifications on Watts products previously or subsequently sold.

Actuator Dimensions

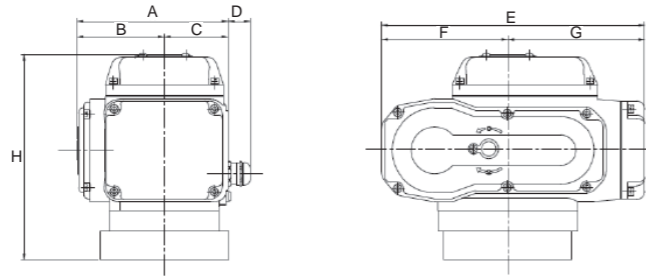

Type	A	B	C	D	E	F	G	H
W-AA1S-5	W-AA1M-5	115	64	51	22	168	82	144
W-AA1S-10	W-AA1M-10	122	68	54	22	208	98	167
W-AA1S-16	W-AA1M-16	122	68	54	22	208	98	167
W-AA1S-25	W-AA1M-25	148	86	62	22	258	124	201
W-AA1S-60	W-AA1M-60	148	86	62	22	258	124	201
W-AA1S-100	W-AA1M-100	156	95	61	22	280	128	251
W-AA1S-200	W-AA1M-200	156	95	61	22	280	128	251
W-AA1S-400	W-AA1M-400	234	140	94	22	325	175	257

Wire Diagram

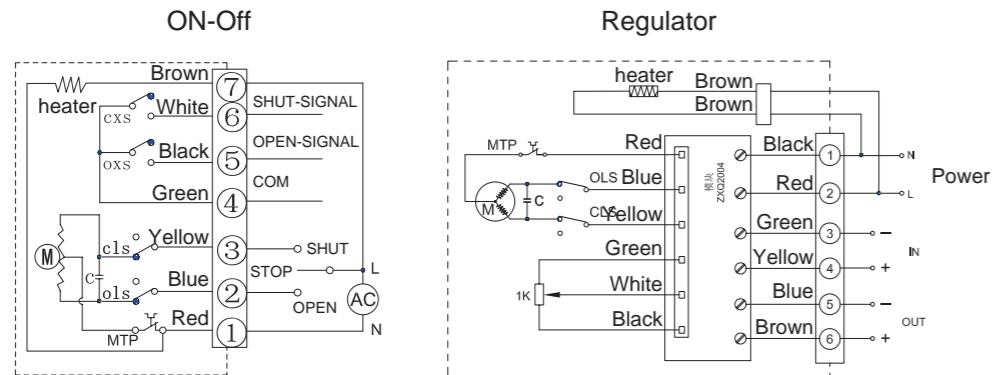

Series W-W1911-EK/ET-ME

On-off/Regulating Electric Butterfly Valve

Size: DN50-DN600

The Watts Series W-W1911-EK-ME and W-W1911-ET-ME Electric butterfly valves are designed and manufactured to meet the stringent requirements of Plumbing, HVAC, irrigation, commercial and Industrial applications.

Features

- Simple structure, easy to operate
- Simple installation, excellent sealing performance
- High reliability and long durability
- Good compatibility
- Good sealing effect, with no pin and no backrest

Pressure - Temperature

- Nominal Pressure: PN16
- Temperature Range: -15°C~120°C

Test Pressures

Hydraulic
Shell: 24 bar
Seat: 17.6 bar

Material

Component	Material
Body	Ductile Iron
Disc	Stainless Steel Aluminum Bronze Ductile Iron (Nickel-plated) Ductile Iron (Epoxy coated)
Seat	EPDM
Stem	Stainless Steel

Characteristic Curves

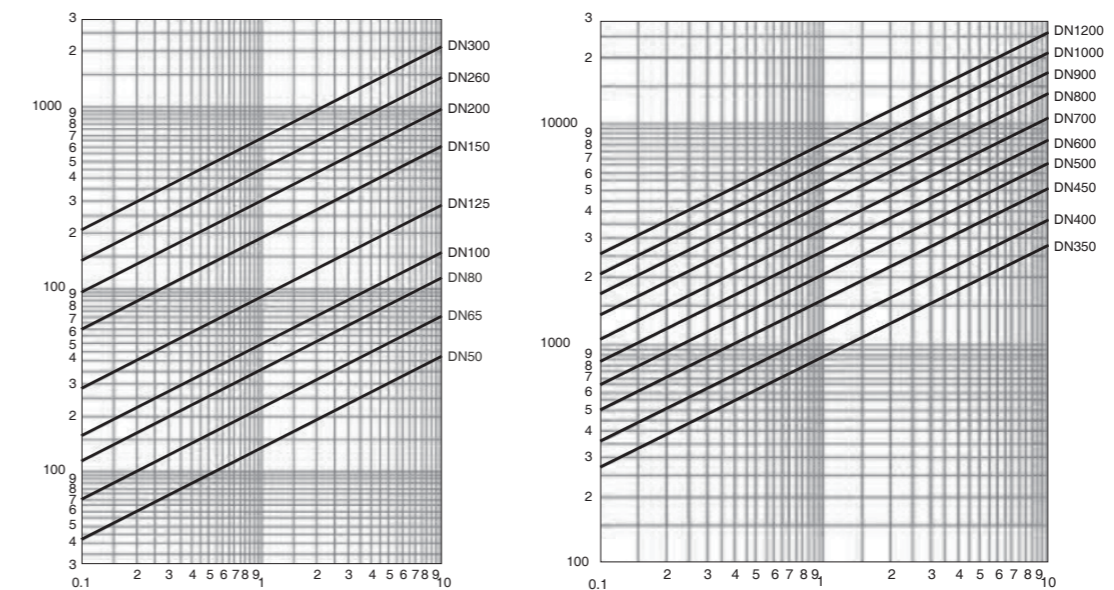

Specification

- Connection Standard: ISO7005-2:1998
BS EN1092-2:1997
- Connection Type: Lug Type
- Medium: water
- Design Standard: EN 593 BS 5155/ MSS SP - 67



Installation Dimensions

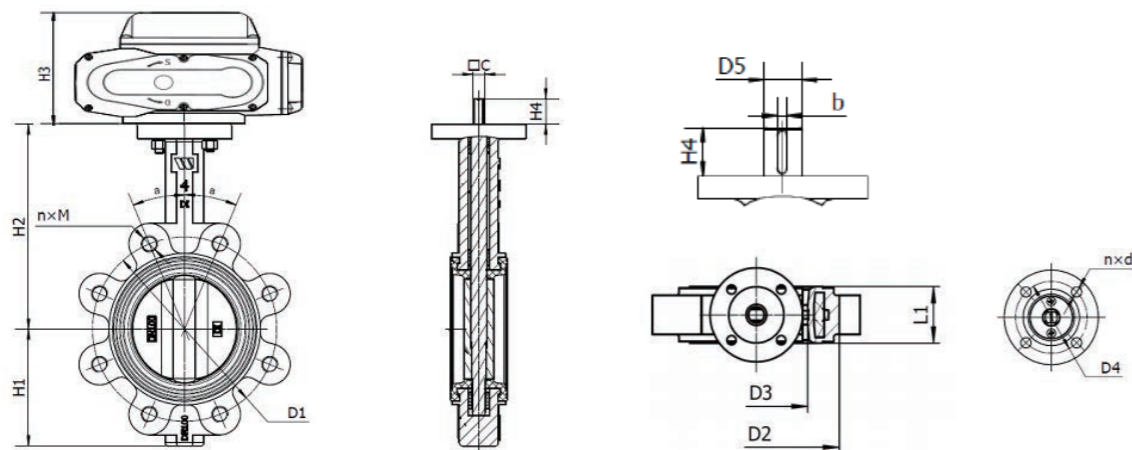

DN	H1	H2	H3	H4	φ E	L1	C/D5	b	D1	n x M	α	D2	D3	D4	n x φ d	Torque(N.m)		Actuator	
																Wet	Dry	Model	Model
50	62	136	144	24	150	43	9	-	φ 125	4xM16	45°	φ 89	φ 51.7	φ 70	4x φ 10	15.1	24.2	W-AA1S-5	W-AA1M-5
65	70	145	144	24	150	46	9	-	φ 145	4xM16	45°	φ 105	φ 63.3	φ 70	4x φ 10	17.2	32.7	W-AA1S-5	W-AA1M-5
80	89	151	144	24	150	46	9	-	φ 160	8xM16	22.5°	φ 120	φ 77.7	φ 70	4x φ 10	23.1	43.7	W-AA1S-5	W-AA1M-5
100	106	170	144	26	150	52	11	-	φ 180	8xM16	22.5°	φ 148	φ 103.1	φ 70	4x φ 10	39.8	72.8	W-AA1S-5	W-AA1M-5
125	119	190	167	26	150	56	14	-	φ 210	8xM16	22.5°	φ 170	φ 122.2	φ 70	4x φ 10	61.9	108	W-AA1S-10	W-AA1M-10
150	131	203	167	26	150	56	14	-	φ 240	8xM20	22.5°	φ 203	φ 154.9	φ 70	4x φ 10	102	174	W-AA1S-16	W-AA1M-16
200	164	245.5	201	26	298	60	17	-	φ 295	12xM20	15°	φ 255	φ 201.3	φ 102	4x φ 12	192	330	W-AA1S-25	W-AA1M-25
250	199	271	201	26	298	68	22	-	φ 355	12xM24	15°	φ 303	φ 249.4	φ 102	4x φ 12	323	549	W-AA1S-60	W-AA1M-60
300	230	296	201	26	298	78	22	-	φ 410	12xM24	15°	φ 355	φ 300.1	φ 102	4x φ 12	490	799	W-AA1S-60	W-AA1M-60
350	288	368	251	40	298	78	φ 31.6	8	φ 470	16xM24	11.25°	φ 405	φ 331.5	φ 102	4x φ 14	625	969	W-AA1S-100	W-AA1M-100
400	331	400	251	52	300	102	φ 33.15	10	φ 525	16xM27	11.25°	φ 470	φ 387.5	φ 140	4x φ 18	846	1307	W-AA1S-200	W-AA1M-200
450	355	422	251	52	300	114	φ 38	10	φ 585	20xM27	9°	φ 525	φ 438.5	φ 140	4x φ 18	1131	1787	W-AA1S-200	W-AA1M-200
500	388	480	309	64	300	127	φ 41.15	10	φ 650	20xM30	9°	φ 578	φ 488.8	φ 140	4x φ 18	1431	2288	W-AA1S-400	W-AA1M-400
600	475	562	309	70	300	154	φ 50.65	16	φ 770	20xM33	9°	φ 693	φ 589.9	φ 165	4x φ 22	2301	3711	W-AA1S-400	W-AA1M-400

Technical Data of Electric Actuator

Switch Type		
Model	Opening/closing time (Sec)	Technical Data
W-AA1S-5	30s	1. Protection rating: IP67 2. Insulation grade: class F 3. Fail safe 4. Limit switch 5. Manual override Power supply voltage: 220-240V/50Hz
W-AA1S-10	30s	
W-AA1S-16	30s	
W-AA1S-25	30s	
W-AA1S-60	30s	
W-AA1S-100	50s	
W-AA1S-200	85s	
W-AA1S-400	75s	

Regulating Type		
Model	Opening/closing time (Sec)	Technical Data
W-AA1M-5	30s	1. Protection rating: IP67 2. Insulation grade: class F 3. Fail safe 4. Manual override 5. Control signal (regulating type): 0-10V Power supply voltage: 220-240V/50Hz
W-AA1M-10	30s	
W-AA1M-16	30s	
W-AA1M-25	30s	
W-AA1M-50	30s	
W-AA1M-100	50s	
W-AA1M-200	85s	
W-AA1M-400	75s	



Series W-W1924-EK-ME

On-off Electric Butterfly Valve

Series W-W1924-ET-ME

Regulating Electric Butterfly Valve

Size: DN50-DN300

The Watts Series W-W1924-EK-ME and W-W1924-ET-ME Electric butterfly valves are designed and manufactured to meet the stringent requirements of Plumbing, HVAC, Irrigation, Commercial and Industrial applications.

Features

- Simple structure, easy to operate;
- Simple installation, excellent sealing performance;
- High reliability and long durability.
- Good compatibility.
- Good sealing effect, with no pin and no backrest.

Pressure-Temperature

- Maximum Working Pressure: PN25
- Temperature Range: -15 C -120 C

Material

Component	Material
Body	Ductile Iron QT450-10
Disc	Stainless Steel CF8M
	Aluminum Bronze C95400
	Ductile Iron QT450-10 (Epoxy coated)
Seat	EPDM
Stem	Stainless Steel 2Cr13

Installation Dimensions

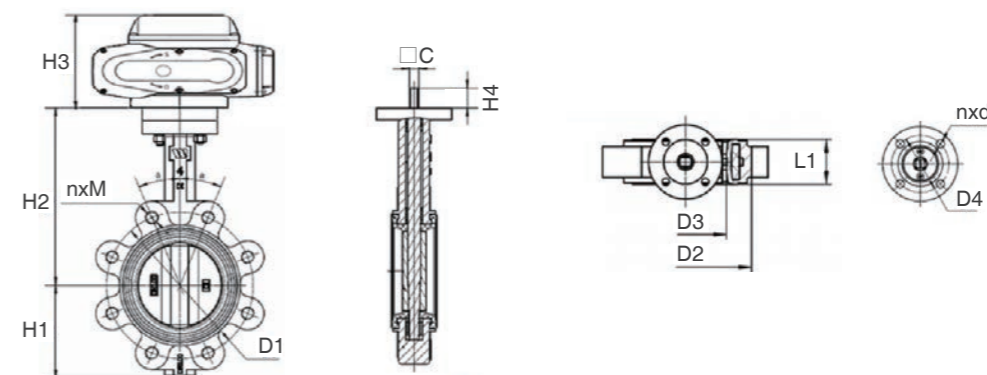

DN	H1	H2	H3	H4	L1	□ C	b	D1	n x M	α	D2	D3	D4	n x d
50	80	161	66	24	43	□ 9	-	φ125	4xM16	45°	φ89	φ51.7	φ70	4Xφ10
65	89	175	66	24	46	□ 9	-	φ145	8xM16	45°	φ105	φ63.3	φ70	4Xφ10
80	95	160	66	24	46	□ 9	-	φ160	8xM16	22.5°	φ120	φ77.7	φ70	4Xφ10
100	114	200	66	26	52	□ 11	-	φ190	8xM20	22.5°	φ148	φ103.1	φ70	4Xφ10
125	127	213	66	26	56	□ 14	-	φ220	8xM24	22.5°	φ170	φ122.2	φ70	4Xφ10
150	146	226	66	26	56	□ 14	-	φ250	8xM24	22.5°	φ203	φ154.9	φ70	4Xφ10
200	185	260	82	26	60	□ 22	-	φ310	12xM24	15°	φ263	φ201.3	φ102	4Xφ12
250	211	292	82	26	68	□ 22	-	φ370	12xM27	15°	φ310	φ249.4	φ102	4Xφ12
300	247	337	84	26	78	□ 27	-	φ430	16xM27	15°	φ363	φ300.1	φ102	4Xφ12



Technical Parameters

Switch Type		
Model	Opening/closing time (Sec)	Technical Data
W-AA1S-5	30s	
W-AA1S-10	30s	1. Protection rating: IP67
W-AA1S-16	30s	2. Insulation grade: class F
W-AA1S-25	30s	3. Fail safe
W-AA1S-60	30s	4. Limit switch
W-AA1S-100	50s	5. Manual override
W-AA1S-200	85s	6. Power supply voltage:220-240V/50Hz
W-AA1S-400	75s	

Regulating Type		
Model	Opening/closing time (Sec)	Technical Data
W-AA1M-5	30s	
W-AA1M-10	30s	1. Protection rating: IP67
W-AA1M-16	30s	2. Insulation grade: class F
W-AA1M-25	30s	3. Fail safe
W-AA1M-60	30s	4. Manual override
W-AA1M-100	50s	5. Control signal (regulating type):0-10V
W-AA1M-200	85s	6. Power supply voltage:220-240V/50Hz
W-AA1M-400	75s	

Installation Instructions

- (1) This valve does not have flow direction of medium requirements, both sides can be used as the inlet or outlet.
- (2) This valve can be installed horizontally, vertically or inclined upward 45 °, and should not be installed with the hand wheel downward.
- (3) Valve should be lifted using flange holes.
- (4) While installation the disc should be kept minimum 25% open

Series W-W1124-EK/ET

Motorized Butterfly Valve - Water Type Wafer Type On/Off & Regulating Type

Size: DN50-DN300

Watts W-W1124-EK/ET can realize medium connection, cut-off and flow control in the pipeline. It can be applied in municipal water supply, industrial and agricultural water transfer pipeline, etc.

Features

- Simple structure, easy to operate
- Easy installation, excellent sealing performance
- Long service life, high reliability
- Good part interchangeability
- A structure with no pin and no backrest ensures more reliable sealing effect

Pressure-Temperature

- Maximum Working Pressure: PN25
- Temperature Range: -15 C -120 C

Material

Component	Material
Body	Ductile Iron+Epoxy Coated
Disc	Ductile Iron (N. Plato) Aluminum Bronze
Seat	EPDM
Stem	Stainless Steel

Installation Dimensions

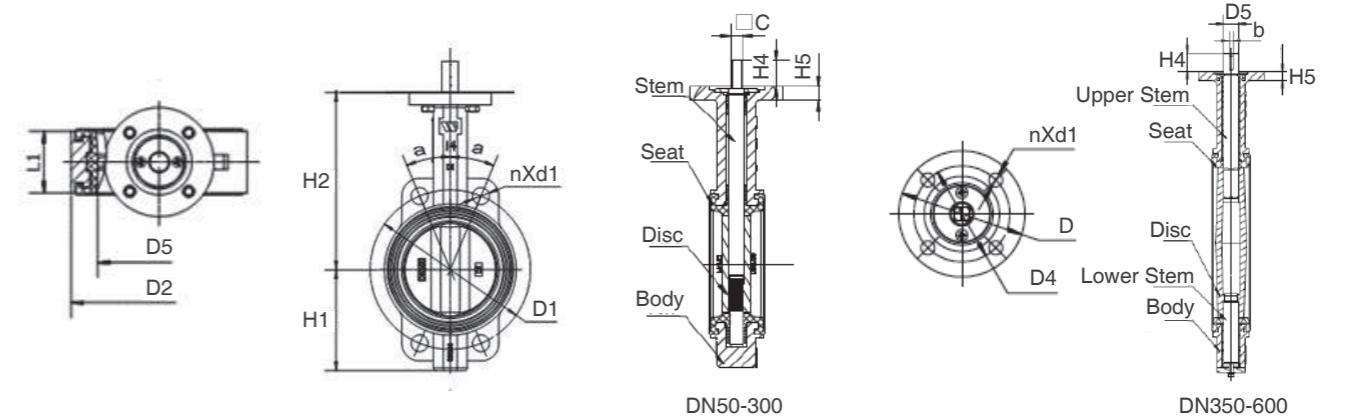

DN	H1	H2	H4	H5	L1	□ C	D2	D5	D1	nxd1	a	D4	nxd	φ3
50	80	161	24	12	43	□ 9	φ89	φ51.7	φ125	4Xφ19	45°	φ70	4Xφ10	φ92
65	89	175	24	13	46	□ 9	φ105	φ63.3	φ145	4Xφ19	22.5°	φ70	4Xφ10	φ92
80	95	181	24	14	46	□ 9	φ120	φ77.7	φ160	4Xφ19	22.5°	φ70	4Xφ10	φ92
100	114	200	26	14	52	□ 11	φ148	φ103.1	φ190	4Xφ23	22.5°	φ70	4Xφ10	φ92
125	127	213	26	14	56	□ 14	φ170	φ122.2	φ220	4Xφ28	22.5°	φ70	4Xφ10	φ92
150	144	226	26	14	56	□ 14	φ203	φ154.9	φ250	4Xφ28	22.5°	φ70	4Xφ10	φ92
200	185	260	33	14	60	□ 22	φ263	φ201.3	φ310	4Xφ28	15°	φ102	4Xφ12	φ125
250	211	292	26	14	68	□ 22	φ310	φ249.4	φ370	4Xφ31	15°	φ102	4Xφ12	φ125
300	247	337	45	20	78	□ 27	φ363	φ300.1	φ430	4Xφ31	11.25°	φ125	4Xφ14	φ150



Specification

- Design Standards: GB/T 13927-2008/EN 593, BSEN 5155/MSS SP-67
- Connection Standard: GB/T 17241.6
- Connection Type: Wafer
- Working Medium: Water

Operating Principles

The electric actuator or the handle controls the rotation of the sealing disc, opening and closing, and flow rate regulation of the valve.

Technical Parameters

Electric Actuator

- Working Voltage: 220VAC (380VAC, 24VDC optional)
- IP Grade: IP67
- Working Temperature: -25 C ~+65 C

Type		Torque N.m	Actuating Times	Power W	Size
On-Off	Regulating				
W-AA1S-5	W-AA1M-5	50	30	52	DN50-100
W-AA1S-10	W-AA1M-10	100	30	70	DN125
W-AA1S-16	W-AA1M-16	160	30	83	DN150
W-AA1S-25	W-AA1M-25	250	30	105	DN200
W-AA1S-60	W-AA1M-60	600	30	220	DN250-300
W-AA1S-100	W-AA1M-100	1000	50	220	DN350
W-AA1S-200	W-AA1M-200	2000	85	264	DN400-450
W-AA1S-400	W-AA1M-400	3500	75	462	DN500-600

Type		A	B	C	D	E	F	G	H
W-AA1S-5	W-AA1M-5	115	64	51	22	168	82	86	144
W-AA1S-10	W-AA1M-10	122	68	54	22	208	98	110	167
W-AA1S-16	W-AA1M-16	122	68	54	22	208	98	110	167
W-AA1S-25	W-AA1M-25	148	86	62	22	258	124	134	201
W-AA1S-60	W-AA1M-60	148	86	62	22	258	124	134	201
W-AA1S-100	W-AA1M-100	156	95	61	22	280	128	152	251
W-AA1S-200	W-AA1M-200	156	95	61	22	280	128	152	251
W-AA1S-400	W-AA1M-400	266	155	111	/	439	189	250	309

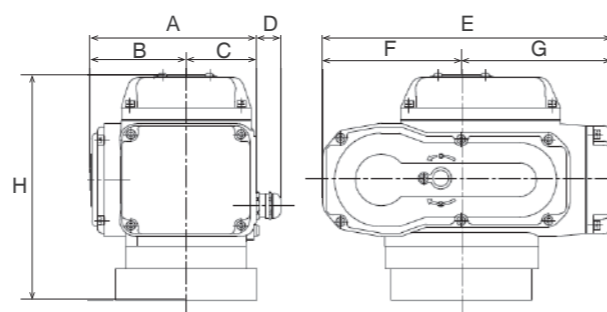

Series W-ECBV-20T

Electric Control Ball Valve

Size: DN15-DN50

W-ECBV series electric control ball valves are widely used in fluid control of central air conditioning, heating, water treatment, industrial processing and other systems. The actuator model used in conjunction is W-A13 series. The actuator receives the standard regulating or switching signals and rotates the ball to the specified position.

Features

- Unique V-shaped inlet design realizes accurate equal percentage flow control characteristics
- Concise structure of flow passage largely avoids blockage, safe and reliable
- High flow capacity, low resistance loss
- Double-seal design, no leakage and double-security
- Ultra-silence channel to ensure quiet environment
- High shut-off pressure, high pressure
- Equipped with manual switch and opening indication

Working Principle

W-ECBV series electric control ball valve is driven by the angular travel actuator W-A13. The actuator drives the valve to change the flow area between the ball and the valve seat by receiving the regulating signal (0 (2)-10V or 0 (4)-20mA) or switching signal, so as to control the flow rate passing through the valve and realize the automatic regulation function.

Material

Component	Material
Valve Body	Brass
Valve Seat	PTFE+EPDM
Valve Ball	DN15-25: Brass HPb59-1 DN32-50: Stainless Steel 304
Valve Shaft	Brass
Seal Ring	HNBR

Product Model

Model	Type	Size	Kvs	Supporting Actuator
W-ECBV2015A(F)-20T	Two-way valve	DN15	5.5	W-A13A series
W-ECBV2020A(F)-20T	Two-way valve	DN20	8	W-A13A series
W-ECBV2025A(F)-20T	Two-way valve	DN25	9	W-A13A series
W-ECBV2032B(F)-20T	Two-way valve	DN32	14.5	W-A13B series
W-ECBV2040C(F)-20T	Two-way valve	DN40	25.9	W-A13C series
W-ECBV2050C(F)-20T	Two-way valve	DN50	39	W-A13C series

Model	Type	Size	Kvs	Side Port Kvs	Supporting Actuator
W-ECBV3015A(F)-20T	Three-way valve	DN15	5.5	3.4	W-A13A series
W-ECBV3020A(F)-20T	Three-way valve	DN20	8	3.4	W-A13A series
W-ECBV3025A(F)-20T	Three-way valve	DN25	9	4.9	W-A13A series
W-ECBV3032B(F)-20T	Three-way valve	DN32	14.5	8	W-A13B series
W-ECBV3040C(F)-20T	Three-way valve	DN40	25.9	12.5	W-A13C series
W-ECBV3050C(F)-20T	Three-way valve	DN50	39	20	W-A13C series



Specification

- Nominal Pressure: PN20
- Working Temperature: 5~95°C
- Protection Level: IP54
- Connection Standard: GB/T 7307-2001
- Turn-off Differential Pressure: 600Kpa
- Flow Characteristics: Equal percentage characteristic curve
- Leakage Rate: Control path ≤0.01%Kvs
Three-way bypass ≤0.5%Kvs
- Regulating Mode: Angular travel 90°
- Working Medium: Air conditioning cold and hot water, ≤50% ethylene glycol/propylene glycol solution

Model Description

W	WATTS	W-	ECBV	2	015	A	F	20	T
ECBV	Electric control ball valve								
Diameter									
2: Two-way		3: Three-way							
Size									
015-DN15:		020-DN20							
025-DN25:		032-DN32							
040-DN40:		050-DN50							
Supporting actuator									
A: 3.5Nm		B: 5Nm							
C: 10Nm		Blank: Not configured							
Control mode									
Blank: regulating type		F: on-off type							
Pressure-bearing grade		PN20							
Valve body material		Copper material							



W-ECBV-20T-EN-202212

Installation Dimensions

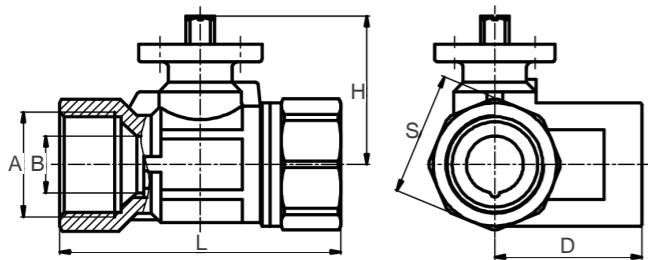

Size	Thread A	Size parameter (mm)				
		L	H	D	S	
DN15	G 1/2"	60	39	30.5	20	
DN 20	G 3/4"	68	43	32	32	
DN 25	G 1"	89	47	46.5	39	
DN 32	G 1-1/4"	103	52.5	49	48	
DN 40	G 1-1/2"	113	57	52	55	
DN 50	G 2"	128	62	69	67	

Wiring Diagram

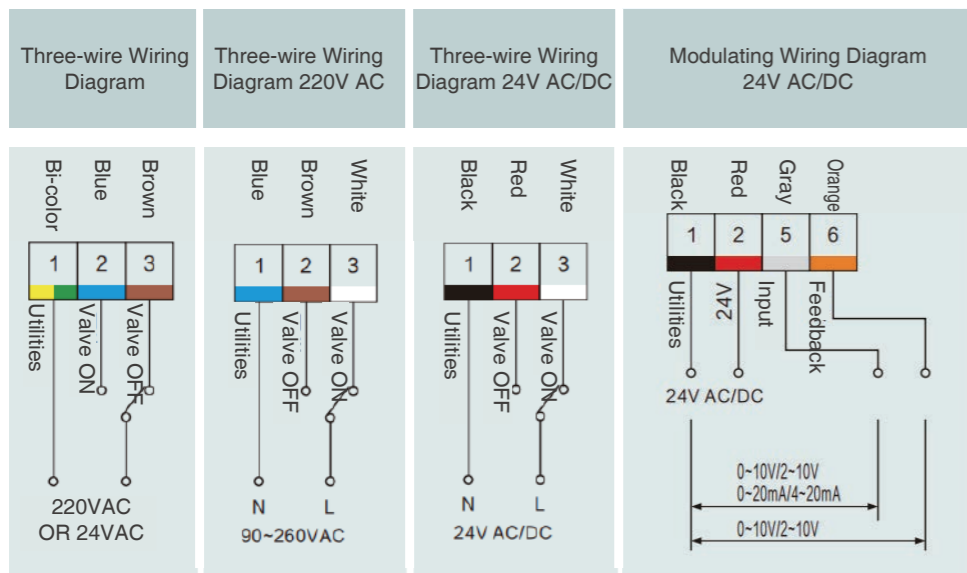

Installation Instruction

1. The two-way control ball valve is recommended to be installed in the return pipe of the system to reduce the thermal stress on the valve;
2. The three-way control ball valve can be used in the shunting or mixed-flow system respectively. When installing, attention shall be paid to the direction of the T-shaped marking slot and switch at the top of the valve stem, as detailed in the schematic diagram below;
3. The ball valve can be installed horizontally or vertically, but it cannot be installed upside down;
4. The product leaves the factory in a closed state.

Characteristic Curve

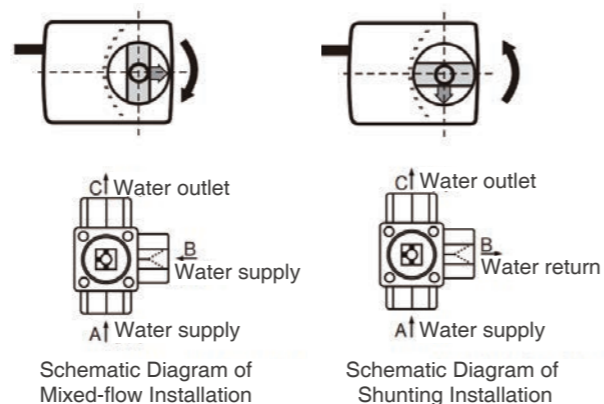
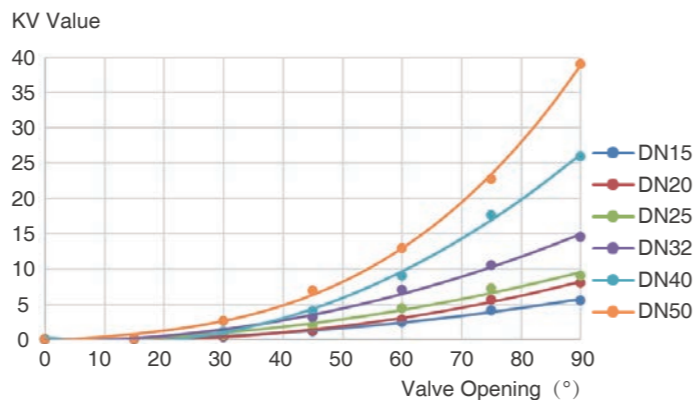

W-ECBV-16Q-EN-202212

Series W-ECBV-16Q

Flange Electric Control Ball Valve

Size: DN65-DN150

W-ECBV series electric control ball valves are widely used in fluid control of central air conditioning, heating, water treatment, industrial processing and other systems. The actuator model used in conjunction is W-A13 series. The actuator receives the standard regulating or switching signals and rotates the ball to the specified position.

Features

- Unique conical inlet design realizes accurate equal percentage flow control characteristics
- Concise structure of flow passage largely avoids blockage, safe and reliable
- High flow capacity, low resistance loss
- Double-seal design, no leakage and double-security
- Ultra-silence channel to ensure quiet environment
- High shut-off pressure, high pressure
- Equipped with manual switch and opening indication

Working Principle

W-ECBV series electric control ball valve is driven by the angular travel actuator W-A13. The actuator drives the valve to change the flow area between the ball and the valve seat by receiving the regulating signal (0 (2)-10V or 0 (4)-20mA) or switching signal, so as to control the flow rate passing through the valve and realize the automatic regulation function.

Material

Component	Material
Valve Body	Ductile Iron
Valve Seat	PTFE+EPDM
Valve Ball	Stainless Steel
Valve Shaft	HPB58-2
Seal Ring	HNBR

Characteristic Curve

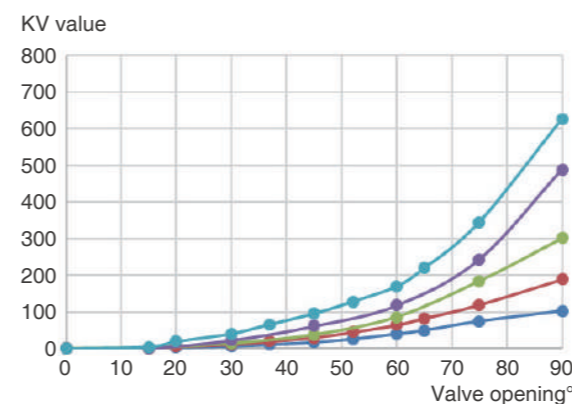

Specification

- Nominal Pressure: PN16
- Working Temperature: 5~95°C
- Protection Level: IP54
- Connection Standard: GB/T 17241.6
- Turn-off Differential Pressure: 600Kpa
- Flow Characteristics: Equal Percentage characteristic curve
- Leakage Rate: Control path ≤0.01%Kvs
- Regulating Mode: Angular travel 90°
- Working Medium: Air conditioning cold and hot water, ≤50% ethylene glycol solution

Product Model

Model	Type	Size	Kvs	Supporting Actuator
W-ECBV2065D-16Q	Two-way valve	DN65	103	W-A13D series
W-ECBV2080D-16Q	Two-way valve	DN80	185	W-A13D series
W-ECBV2100E-16Q	Two-way valve	DN100	300	W-A13E series
W-ECBV2125F-16Q	Two-way valve	DN125	480	W-A13F series
W-ECBV2150F-16Q	Two-way valve	DN150	600	W-A13F series

Model Description

W	WATTS
ECBV	Electric control ball valve
2	Two-way
065	065-DN65:
D	100-DN100:
F	150-DN150:
16	Supporting actuator
Q	D: 15Nm E: 20Nm F: 30Nm Blank: Not configured
	Control mode
	Blank: regulating type F: on-off type
	Pressure-bearing grade PN16
	Valve body material Ductile iron



Installation Dimensions

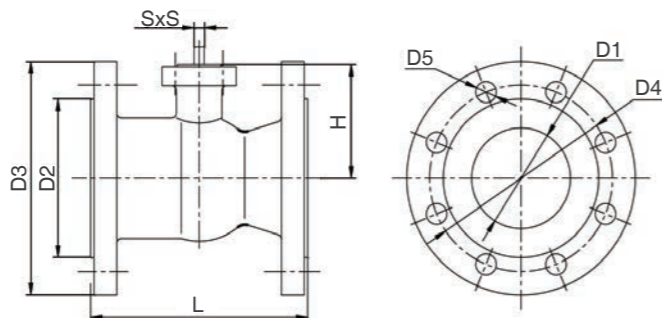

Size	L (mm)	H (mm)	D1 (mm)	D2 (mm)	D3 (mm)	D4 (mm)	D5 (mm)	SxS (mm)	Number of D5 passing through the bolt holes	Bolt thread Th
DN65	190	86	43	120	185	145	18	10x10	4	M16
DN80	203	94	54	136	200	160	18	10x10	8	M16
DN100	229	103	65	156	220	180	18	12x12	8	M16
DN125	245	117	84	188	250	210	18	12x12	8	M16
DN150	250	130	100	210	285	240	22	12x12	8	M20

Wiring Diagram

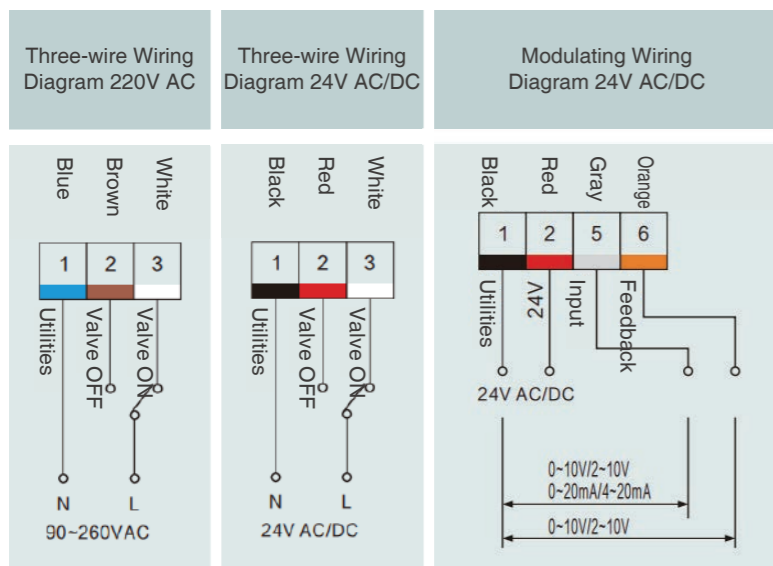

Installation Instruction

1. The two-way control ball valve is recommended to be installed in the return pipe of the system to reduce the thermal stress on the valve;
2. The three-way control ball valve can be used in the shunting or mixed-flow system respectively. When installing, attention shall be paid to the direction of the T-shaped marking slot and switch at the top of the valve stem, as detailed in the schematic diagram below;
3. The ball valve can be installed horizontally or vertically, but it cannot be installed upside down;
4. The product leaves the factory in a closed state.



Series W-942-16/25Q

Electrical Two-way Control Valve

Size: DN15-DN500

The Series W-942-16/25Q Electrical Two-way Control Valves are used with Series W-A11 actuators. They are extensively applied to HVAC water systems, boiler systems, heat exchange systems or AHU steam systems to regulate the flow rates of fluids in these systems.

Features

- Equal percentage control characteristic achieves high control precision
- Electronic presetting function facilitates on-site commissioning
- Automatic fault detection and alarm functions
- Overload protection function for the power supply
- V-shaped (cone) sealing ring and spring self-compensation structure result in higher abrasion resistance and longer service life

Pressure-Temperature

- Nominal Pressure: PN16 / PN25 (Water Valve)
- Temperature Range: -25 C ~150 C (Water Valve)
2 C ~180 C (Steam Valve)
2 C ~220 C (High-temperature Steam Valve)

Material

Component	Material
Valve Body	Ductile Iron
Valve Core	Stainless Steel
Valve Stem	Stainless Steel
Spring	Stainless Steel
Sealing	FPM

Operating Principles

Once the valve's actuator receives a control signal from the BA System, it will regulate the valve's opening rate by moving the valve stem, and thus change the system's flow rate.

Technical Parameters

Water Valve

Type	Size	Kvs	Stroke (mm)	Actuator Force(N)	Shutoff ΔP(KPa)
W-942AW015-16Q	DN15	2	20	500	≤ 1600
W-942AW020-16Q	DN20	3	20	500	≤ 1100
W-942AW025-16Q	DN25	5	20	500	≤ 700
W-942AW032-16Q	DN32	8	20	500	≤ 400
W-942AW040-16Q	DN40	20	20	500	≤ 250
W-942BW050-16Q	DN50	31	20	1000	≤ 300
W-942CW065-16Q	DN65	50	20	1800	≤ 450
W-942CW080-16Q	DN80	80	20	1800	≤ 300
W-942DW100-16Q	DN100	125	40	3000	≤ 280
W-942DW125-16Q	DN125	200	40	3000	≤ 1600
W-942DW150-16Q	DN150	300	40	3000	≤ 1600
W-942EW200-16Q	DN200	520	40	5000	≤ 1600
W-942EW250-16Q	DN250	750	40	5000	≤ 1600
W-942FW300-16Q	DN300	1200	100	16000	≤ 1600
W-942FW350-16Q	DN350	1800	100	16000	≤ 1600
W-942FW400-16Q	DN400	2200	100	16000	≤ 1600
W-942FW450-16Q	DN450	2600	100	16000	≤ 1600
W-942FW500-16Q	DN500	3200	100	16000	≤ 1600

Steam Valve

Type	Size	Kvs	Stroke (mm)	Actuator Force(N)	Shutoff ΔP(KPa)
W-942AS015-16Q	DN15	2	20	500	≤ 1000
W-942AS020-16Q	DN20	3	20	500	≤ 1000
W-942BS025-16Q	DN25	5	20	1000	≤ 1000
W-942BS032-16Q	DN32	8	20	1000	≤ 600
W-942CS040-16Q	DN40	20	20	1800	≤ 1600
W-942CS050-16Q	DN50	31	20	1800	≤ 1600
W-942DS065-16Q	DN65	50	20	3000	≤ 1600
W-942DS080-16Q	DN80	80	20	3000	≤ 1600
W-942DS100-16Q	DN100	125	40	3000	≤ 1600
W-942DS125-16Q	DN125	200	40	3000	≤ 1600
W-942DS150-16Q	DN150	300	40	3000	≤ 1600
W-942ES200-16Q	DN200	520	40	5000	≤ 1600
W-942ES250-16Q	DN250	750	40	5000	≤ 1600
W-942FS300-16Q	DN300	1200	100	16000	≤ 1600
W-942FS350-16Q	DN350	1800	100	16000	≤ 1600
W-942FS400-16Q	DN400	2200	100	16000	≤ 1600
W-942FS450-16Q	DN450	2600	100	16000	≤ 1600
W-942FS500-16Q	DN500	3200	100	16000	≤ 1600



Specification

- Connection Standard: ISO7005
- Connection Type: Flange Connection
- Flow Deviation: ±5%
- Function: Two-way Control
- Control Characteristic: Equal Percentage
- Leak Rate: ≤ 0.02% Kvs
- Working Medium: Water / Ethylene Glycol / Propylene Glycol / Steam

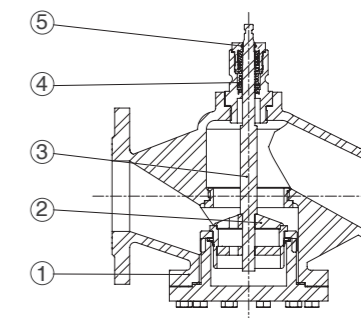

High-Temperature Steam Valve

Type	Size	Kvs	Stroke (mm)	Actuator Force(N)	Shutoff ΔP(KPa)
W-942CT015-16Q	DN15	2	20	1800	≤ 1600
W-942CT020-16Q	DN20	3	20	1800	≤ 1600
W-942CT025-16Q	DN25	5	20	1800	≤ 1600
W-942CT032-16Q	DN32	8	20	1800	≤ 1600
W-942CT040-16Q	DN40	20	20	1800	≤ 1600
W-942CT050-16Q	DN50	31	20	1800	≤ 1600
W-942DT065-16Q	DN65	50	20	3000	≤ 1600
W-942DT080-16Q	DN80	80	20	3000	≤ 1600
W-942DT100-16Q	DN100	125	40	3000	≤ 1600
W-942DT125-16Q	DN125	200	40	3000	≤ 1600
W-942DT150-16Q	DN150	300	40	3000	≤ 1600
W-942ET200-16Q	DN200	520	40	5000	≤ 1600
W-942ET250-16Q	DN250	750	40	5000	≤ 1600
W-942FT300-16Q	DN300	1200	100	16000	≤ 1600
W-942FT350-16Q	DN350	1800	100	16000	≤ 1600
W-942FT400-16Q	DN400	2200	100	16000	≤ 1600
W-942FT450-16Q	DN450	2600	100	16000	≤ 1600
W-942FT500-16Q	DN500	3200	100	16000	≤ 1600

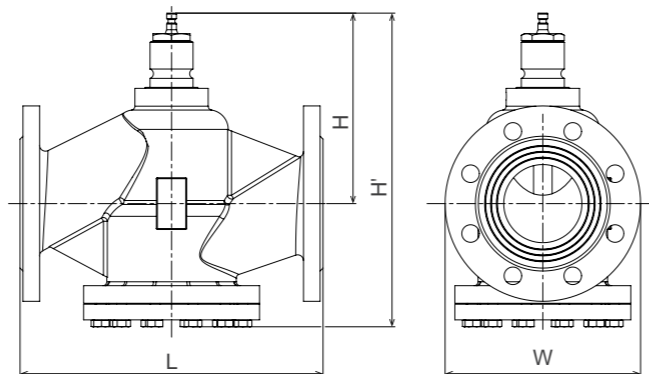

Installation Dimensions

The valve must be installed vertically. The arrow head on the valve body should be in line with the direction of the flow. The connection of the valves' flanges and the pipe ought to be coaxial with all the bolts equally fastened. As for the electronic actuator, its wiring should be correct, and it cannot be exposed to water.

Size	L(mm)	H(mm)	H'(mm)	W(mm)	H-1(mm)	H-2(mm)	H-3(mm)	H-4(mm)	Weight(Kg)
DN15	130	107	177	95	269	378	407	/	3.7
DN20	150	107	177	105	269	378	407	/	4.3
DN25	160	112	187	115	274	383	412	/	5.4
DN32	180	121	201	140	283	392	421	/	7.7
DN40	200	126	208	150	288	397	426	/	9.2
DN50	230	136	234	165	298	407	436	/	12.5
DN65	290	166	278	185	328	437	466	/	18.5
DN80	310	196	326	200	358	467	496	/	25
DN100	350	212	362	220	/	483	512	/	35.6
DN125	400	233	408	250	/	504	533	/	50.6
DN150	480	247	447	285	/	518	547	/	71.5
DN200	500	339	575	340	/	610	639	/	112.7
DN250	600	391	681	405	/	662	691	/	202
DN300	700	485	807	460	/	/	/	1084	340
DN350	788	565	965	520	/	/	/	1164	467
DN400	912	615	1037	580	/	/	/	1214	589
DN450	980	586	1006	640	/	/	/	1187	712
DN500	978	650	1170	715	/	/	/	1247	878

*H-1: when connected to a 500N/1000N actuator
 H-2: when connected to an 1800N/3000N/5000N actuator without manual lever
 H-3: when connected to an 1800N/3000N/5000N actuator with manual lever
 H-4: when connected to a 16000N actuator

Series W-943-16/25Q

Electrical Three-way Control Valve

Size: DN15-DN500

The Series W-943-16/25Q Electrical Two-way Control Valves are used with Series W-A11 actuators. They are extensively applied to HVAC water systems, boiler systems, heat exchange systems or AHU steam systems to regulate the flow rates of fluids in these systems.

Features

- Equal percentage control characteristic achieves high control precision
- Electronic presetting function facilitates on-site commissioning
- Automatic fault detection and alarm functions
- Overload protection function for the power supply
- V-shaped (cone) sealing ring and spring self-compensation structure result in higher abrasion resistance and longer service life

Pressure-Temperature

- Nominal Pressure: PN16 / PN25
- Temperature Range: -25 C ~150 C

Material

Component	Material
Valve Body	Ductile Iron
Valve Core	Stainless Steel
Valve Stem	Stainless Steel
Spring	Stainless Steel
Sealing	FPM

Operating Principles

Once the valve's actuator receives the control signal from the BA System, it will regulate the valve's opening rate by moving the valve stem, and thus change the system's flow rate.

Specification

- Connection Standard: ISO7005
- Connection Type: Flange Connection
- Flow Deviation: ±5%
- Function: Three-way Mixing / Diverting Control
- Control Characteristic: Equal Percentage
- Leak Rate: ≤ 0.02% Kvs
- Working Medium: Water / Ethylene Glycol / Propylene Glycol



Technical Parameters

Type	Size	Kvs	Stroke (mm)	Actuator Force(N)	Shutoff ΔP(KPa)	Remark
W-943AW015-16Q	DN15	2	20	500	≤800	Mixing Valve
W-943AW020-16Q	DN20	3	20	500	≤800	Mixing Valve
W-943AW025-16Q	DN25	5	20	500	≤800	Mixing Valve
W-943AW032-16Q	DN32	8	20	500	≤800	Mixing Valve
W-943AW040-16Q	DN40	20	20	500	≤800	Mixing Valve
W-943BW050-16Q	DN50	31	20	1000	≤300	Mixing Valve
W-943CW065-16Q	DN65	50	20	1800	≤450	Mixing Valve
W-943HCW080-16Q	DN80	80	20	1800	≤270	Mixing Valve
W-943FCW080-16Q	DN80	80	20	1800	≤270	Diverting Valve
W-943HDW100-16Q	DN100	125	40	3000	≤200	Mixing Valve
W-943FDW100-16Q	DN100	125	40	3000	≤200	Diverting Valve
W-943HDW125-16Q	DN125	200	40	3000	≤150	Mixing Valve
W-943FDW125-16Q	DN125	200	40	3000	≤150	Diverting Valve
W-943HDW150-16Q	DN150	300	40	3000	≤100	Mixing Valve
W-943FDW150-16Q	DN150	300	40	3000	≤100	Diverting Valve
W-943HEW200-16Q	DN200	520	40	5000	≤130	Mixing Valve
W-943FEW200-16Q	DN200	520	40	5000	≤130	Diverting Valve
W-943HEW250-16Q	DN250	750	40	5000	≤80	Mixing Valve
W-943FEW250-16Q	DN250	750	40	5000	≤80	Diverting Valve
W-943HFW300-16Q	DN300	1200	100	16000	≤250	Mixing Valve
W-943FFW300-16Q	DN300	1200	100	16000	≤250	Diverting Valve
W-943HFW350-16Q	DN350	1800	100	16000	≤150	Mixing Valve
W-943FFW350-16Q	DN350	1800	100	16000	≤150	Diverting Valve
W-943HFW400-16Q	DN400	2200	100	16000	≤100	Mixing Valve
W-943FFW400-16Q	DN400	2200	100	16000	≤100	Diverting Valve
W-943HFW450-16Q	DN450	2600	100	16000	≤80	Mixing Valve
W-943FFW450-16Q	DN450	2600	100	16000	≤80	Diverting Valve
W-943HFW500-16Q	DN500	3200	100	16000	≤60	Mixing Valve
W-943FFW500-16Q	DN500	3200	100	16000	≤60	Diverting Valve

*DN15-DN65 are mixing valves. They can be used as diverting valves when installed in different direction. Other performance parameters of PN 16 are the same as those of PN25.

Installation Dimensions

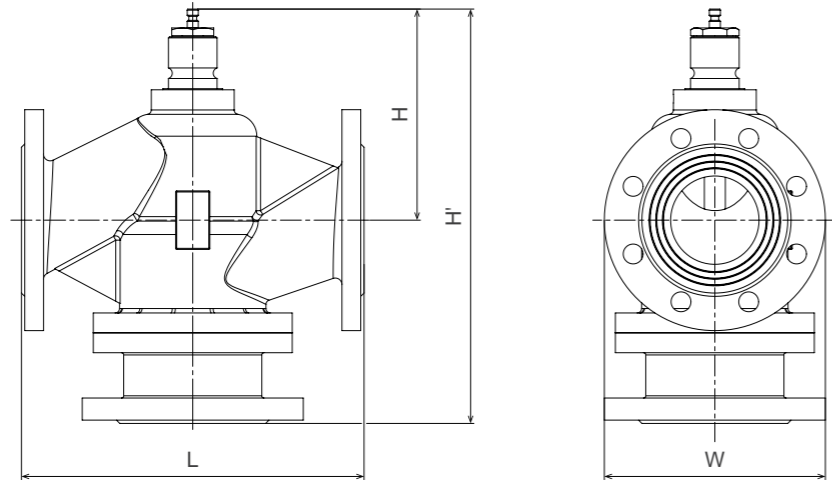

Size	L(mm)	H(mm)	H'(mm)	W(mm)	H-1(mm)	H-2(mm)	H-3(mm)	H-4(mm)	Weight(Kg)	
DN15	130	107	213	95	269	378	407	/	5.5	
DN20	150	107	213	105	269	378	407	/	5.5	
DN25	160	112	223	115	274	383	412	/	6.5	
DN32	180	121	242	140	283	392	421	/	9.4	
DN40	200	126	248	150	288	397	426	/	11	
DN50	230	136	272	165	298	407	436	/	14.8	
DN65	290	166	322	185	328	437	466	/	22.5	
DN80	310	196	381	200	358	467	496	/	28.8	
DN100	350	238	440	220	/	483	512	/	40.6	
DN125	400	233	473	250	/	504	533	/	55.4	
DN150	480	247	517	285	/	518	547	/	76.3	
DN200	500	339	659	340	/	610	639	/	125.6	
DN250	600	391	791	405	/	662	691	/	230	
DN300	Mixing	700	475	932	460	/	694	723	1074	369
DN300	Diverting	700	538	995	/	/	757	786	1137	369
DN350		788	565	1085	520	/	/	/	1164	521
DN400		912	615	1210	580	/	/	/	1214	643
DN450		980	586	1266	640	/	/	/	1187	758
DN500		978	650	1400	715	/	/	/	1247	926

*H-1: when connected to a 500N/1000N actuator
 H-2: when connected to an 1800N/3000N/5000N actuator without manual lever
 H-3: when connected to an 1800N/3000N/5000N actuator with manual lever
 H-4: when connected to a 16000N actuator

Series 2131

Fan Coil Valve

Size: DN15-DN25

2131 Series fan coil control valves are used for controlling the flow of hot or cold water in heating and air conditioning systems. They are operated by actuators with the effective stroke of 2.5 mm, such as the 22C, 22CX, 22CX5, and 26LC Series electro-thermal actuators.

Features

- 2-way control valve
- ON/OFF operation with 22C, 22CX, 22CX5, and 26LC series actuators

Pressure-Temperature

- Nominal Pressure: PN16
- Temperature Range: 4°C~110°C

Typical Application

- HVAC systems
- Fan coils units
- Chilled water units

Material

Component	Material
Body	brass
Stem	chemical nickel-plated brass
Spring	stainless steel
Disc rubber	EPDM

Installation Dimensions

PART NO.	DN	A	B	C	D
213112	1/2"	52	29	13.5	51
213112P	1/2"	52	29	13.5	51
213112DP	1/2"	52	45	13.5	70
21311012	1/2"	52	29	13.5	51
213112P04	1/2"	52	29	13.5	51
213112P063	1/2"	52	29	13.5	51
213112P01	1/2"	52	29	13.5	51
213134	3/4"	56	28	13.5	56
213134P	3/4"	56	28	13.5	56
213134P4	3/4"	56	36	13.5	72
213134DP	3/4"	56	44	13.5	72
21311034	3/4"	56	28	13.5	56
21311	1"	82	38	13.5	70
21311P	1"	82	38	13.5	70
21311DP	1"	82	38	13.5	77.5
2131101	1"	82	30.5	13.5	77.5



Specification

- Connection Type: threaded, male

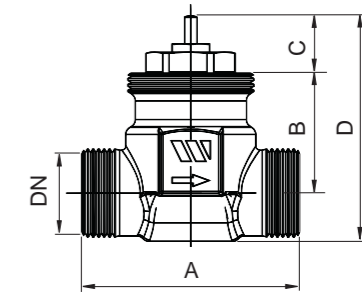

Kv Value

Valve part No.	DN	DN mm	Max. operating pressure PN [bar]	Kvs
2-way valve				
213112	1/2"	15	16	1.7
213112P	1/2"	15	16	1.7
213112DP	1/2"	15	16	1.7
21311012	1/2"	15	10	1.7
213112P04	1/2"	15	16	0.4
213112P063	1/2"	15	16	0.63
213112P1	1/2"	15	16	1
213134	3/4"	20	16	2.8
213134P	3/4"	20	16	2.8
213134P4	3/4"	20	16	4
213134DP	3/4"	20	16	2.8
21311034	3/4"	20	10	2.8
21311	1"	25	16	4.5
21311P	1"	25	16	4.5
21311DP	1"	25	16	4
2131101	1"	25	10	4.5



Characteristic Curve

Nominal Diameter 15mm (1/2")

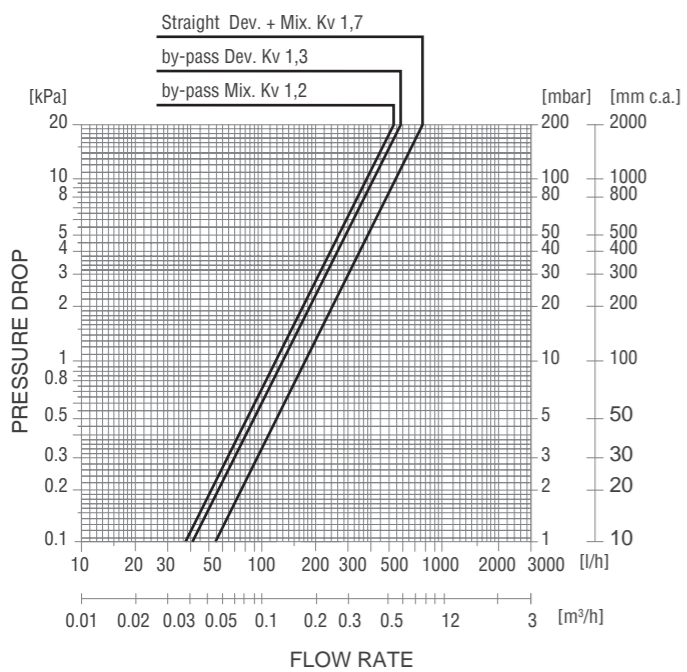

Nominal Diameter 20mm (3/4")

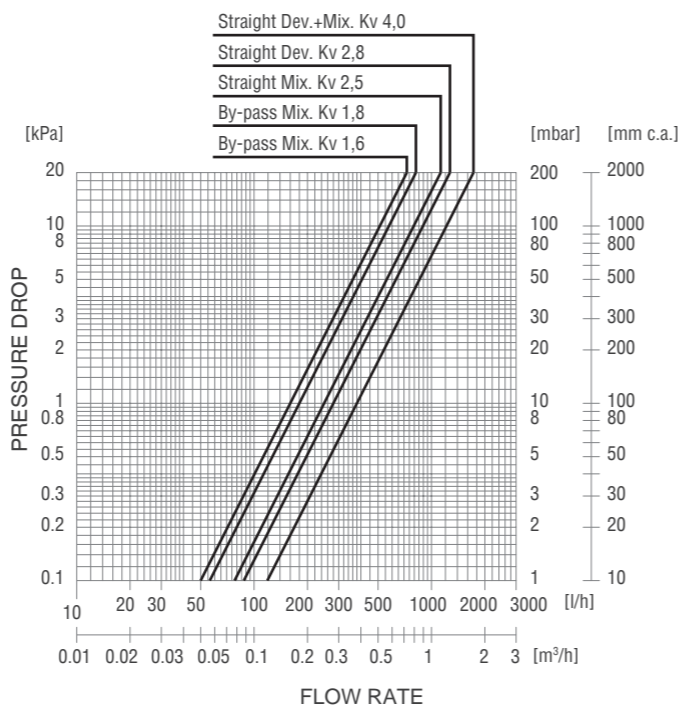

Nominal Diameter 25mm (1")

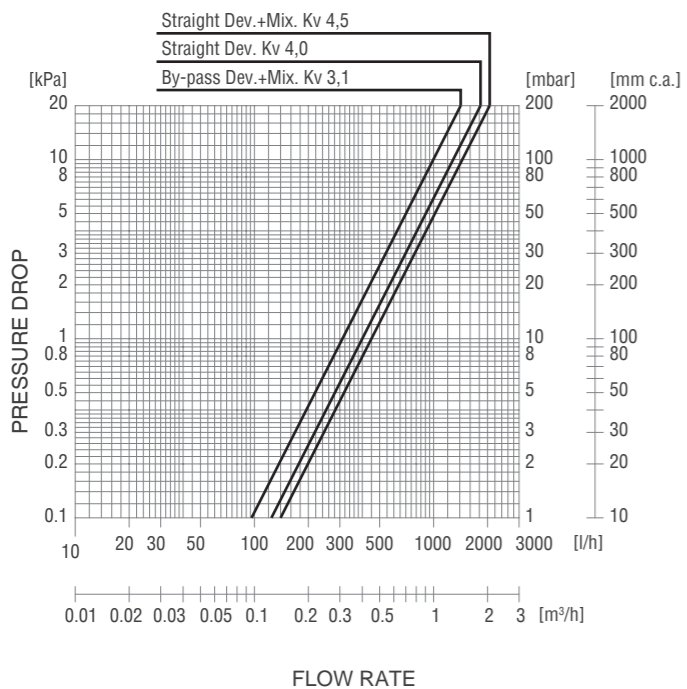

Nominal Diameter 15mm (1/2")-Reduced Kv

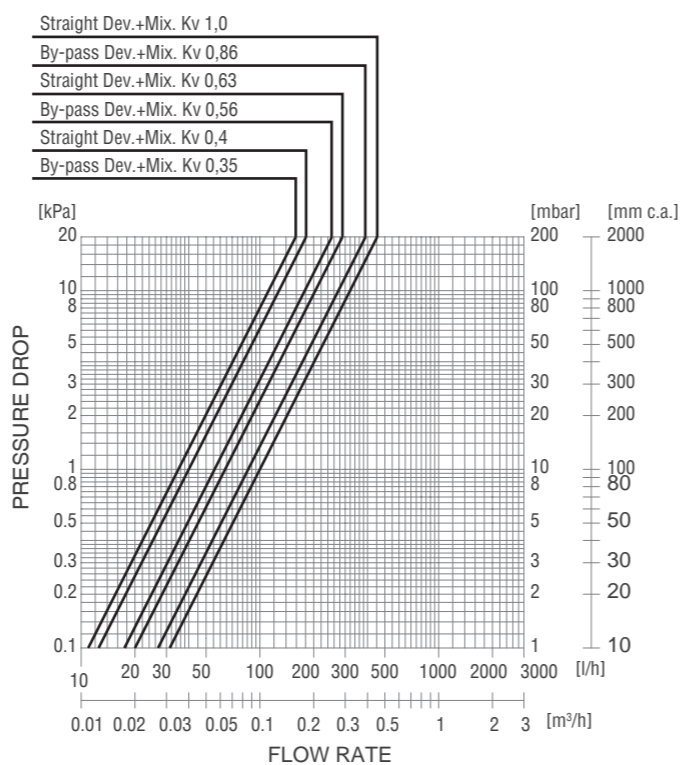

Series 3131

Fan Coil Valve

Size: DN15-DN25

3131 Series fan coil control valves are used for controlling the flow of hot or cold water in heating and air conditioning systems. They are operated by actuators with effective stroke of 2.5 mm, such as the 22C, 22CX, 22CX5, and 26LC Series electro-thermal actuators.

Features

- The 3-way control valve-can be used as amixing valve and diverter valve
- On/Off operation with 22C, 22CX, 22CX5, and 26LC series actuators

Pressure-Temperature

- Nominal Pressure: PN16
- Temperature Range: 4°C~110°C

Material

Component	Material
Body	brass
Stem	chemical nickel-plated brass
Spring	stainless steel
Disc rubber	EPDM

Installation Dimensions

PART NO.	DN	A	B	C	D
313112	1/2"	52	29	13.5	68.5
313112P	1/2"	52	29	13.5	68.5
313112P04	1/2"	52	45	13.5	68.5
313112P063	1/2"	52	29	13.5	68.5
313112P1	3/4"	52	29	13.5	68.5
313134	3/4"	56	28	13.5	69.5
313134P	3/4"	56	28	13.5	69.5
213134P4	3/4"	68	38	13.5	92.5
313111	1"	82	38	13.5	92.5
31311P	1"	82	38	13.5	92.5

Kv Value

Valve part No.	DN	DN mm	Max. operating pressure PN [bar]	Kvs	Kvs bypass	Δ Pmax Max. operating pressure differential (noise < 38 dBA) [bar]	Δ Ps Closure with 22CX-EMUJC actuator [bar]	Kvs	Kvs bypass	Δ Pmax Max. operating pressure differential (noise < 38 dBA) [bar]	Δ Ps Closure with 22CX-EMUJC actuator [bar]
3-way valve											
						Used as DIVERTER VALVE			Used as MIXING VALVE		
313112	1/2"	15	16	1.7	1.3	0.8	2.5	1.7	1.2	0.7	2
313112P	1/2"	15	16	1.7	1.3	0.8	2.5	1.7	1.2	0.7	2
313112P04	1/2"	15	16	0.4	0.35	0.8	2.5	0.4	0.35	0.7	2
313112P063	1/2"	15	16	0.63	0.56	0.8	2.5	0.63	0.56	0.7	2
313112P1	1/2"	15	16	1	0.86	0.8	2.5	1	0.86	0.7	2
313134	3/4"	20	16	2.8	1.8	0.7	1.5	2.5	1.6	0.5	1
313134P	3/4"	20	16	2.8	1.8	0.7	1.5	2.5	1.6	0.5	1
313134P4	3/4"	20	16	4	1.8	0.7	1	4	1.6	0.5	0.8
313111	1"	25	16	4.5	3.1	0.6	0.7	4.5	3.1	0.4	0.7
31311P	1"	25	16	4.5	3.1	0.6	0.7	4.5	3.1	0.4	0.7



Specification

- Connection Type: Threaded, Male

Typical Application

Fan Coil Units, Chilled water & HVAC system

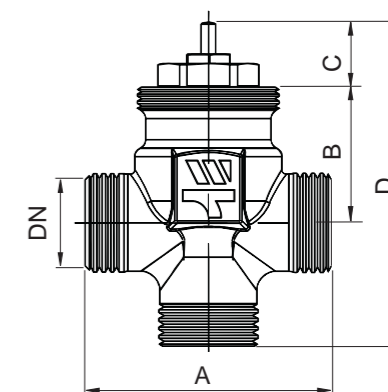



Characteristic Curve

Nominal Diameter 15mm (1/2")

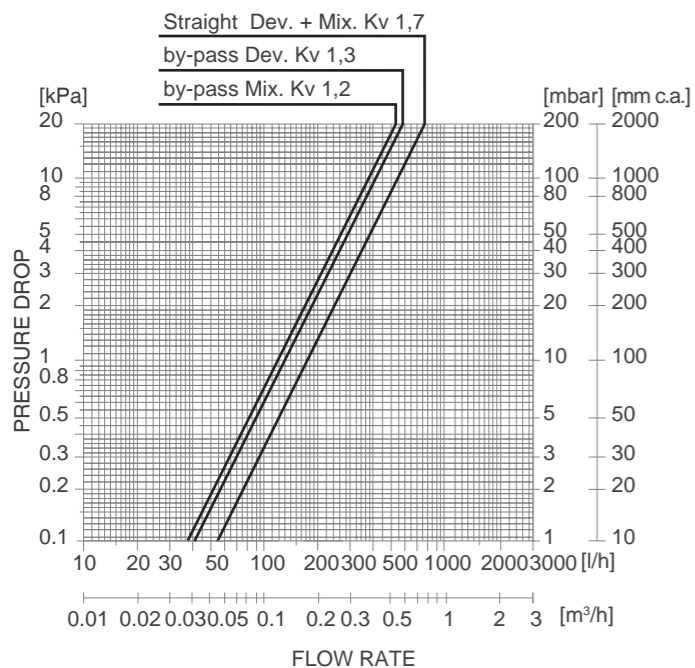

Nominal Diameter 20mm (3/4")

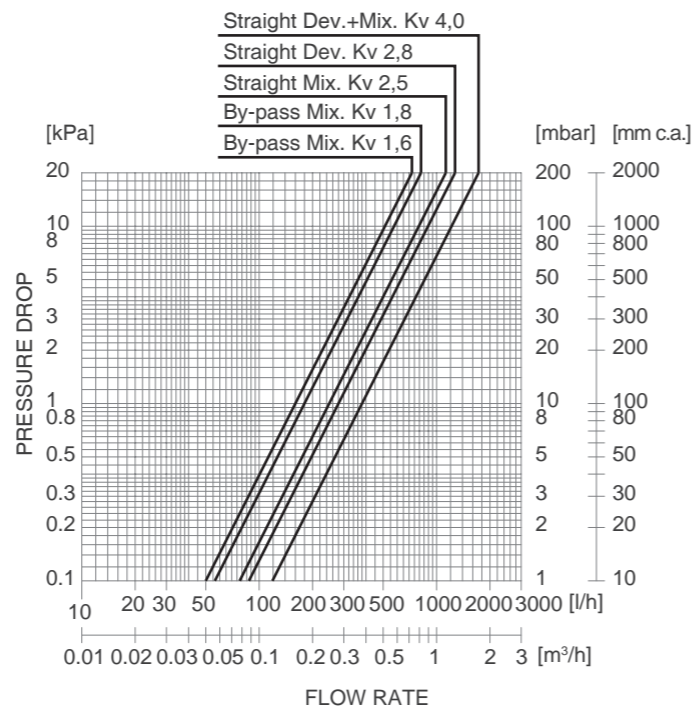

Nominal Diameter 25mm (1")

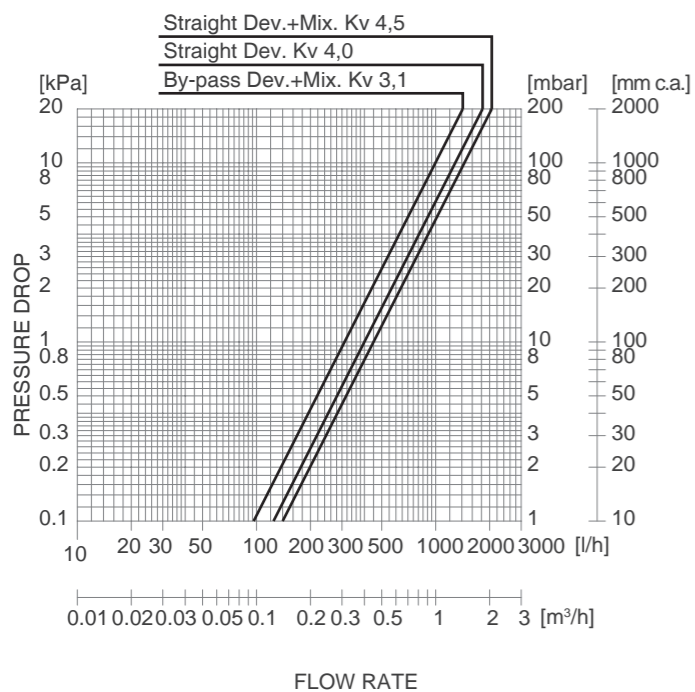

Nominal Diameter 15mm (1/2")-Reduced Kv

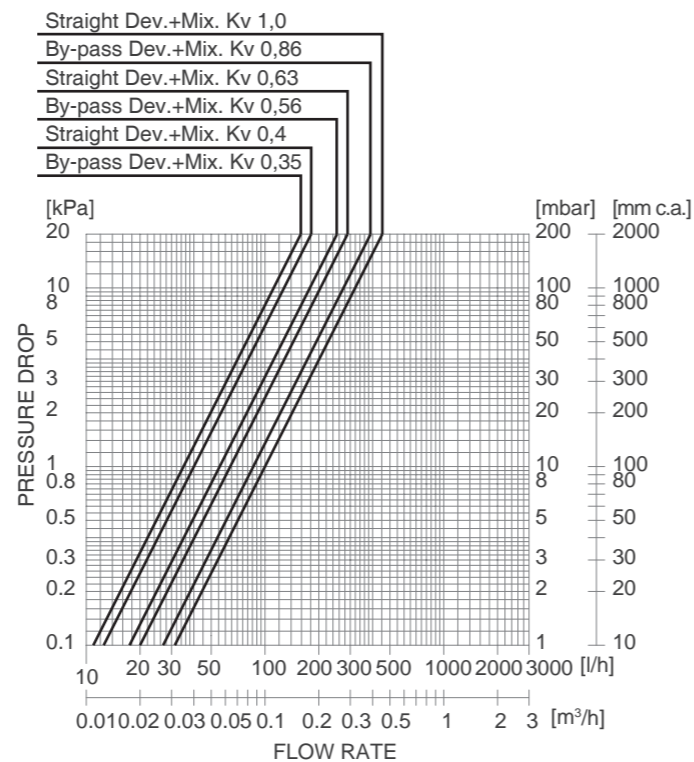

Series 4131

Fan Coil Valve

Size: DN15-DN20

4131 Series fan coil control valves are used for controlling the flow of hot or cold water in heating and air conditioning systems. They are operated by actuators with effective stroke of 2.5 mm, such as the 22C, 22CX, 22CX5, and 26LC Series electro-thermal actuators.

Features

- The 3-way 4-port control valve, can be used as amixing valve and diverter valve
- On/Off operation with 22C, 22CX, 22CX5, and 26LC series actuators
- Disc stroke 2.5mm

Pressure-Temperature

- Nominal Pressure: PN16
- Temperature Range: 4°C-110°C

Material

Component	Material
Body	Brass
Stem	Chemical nickel-plated brass
Spring	Stainless Steel
Disc rubber	EPDM

Installation Dimensions

PART NO.	DN	A	B	C	D	E
413112	1/2"	52	29	13.5	95.5	35
413112P	1/2"	52	29	13.5	95.5	35
4131124DP	1/2"	52	29	13.5	100.5	40
4131124DP04	1/2"	52	29	13.5	100.5	40
4131124DP063	1/2"	52	29	13.5	100.5	40
4131124DP1	1/2"	52	29	13.5	100.5	40
413134	3/4"	56	28	13.5	112.5	50
413134P	3/4"	56	28	13.5	112.5	50
4131244DP	3/4"	56	28	13.5	102.5	40
4131344DP4	3/4"	68	38	13.5	100.5	40

Kv Value

Valve part No.	DN	DN mm	Max. operating pressure PN [bar]	Kvs	Kvs bypass	Δ Pmax Max. operating pressure differential (noise < 38 dBA) [bar]	Δ Ps Closure with 22CX-EMUJC actuator [bar]	Kvs	Kvs bypass	Δ Pmax Max. operating pressure differential (noise < 38 dBA) [bar]	Δ Ps Closure with 22CX-EMUJC actuator [bar]
3-way 4-port valve						Used as DIVERTER VALVE			Used as MIXING VALVE		
413112	1/2"	15	16	1.7	1.3	0.8	2.5	1.7	1.2	0.7	2
413112P	1/2"	15	16	1.7	1.3	0.8	2.5	1.7	1.2	0.7	2
4131124DP	1/2"	15	16	1.7	1.3	0.8	2.5	1.7	1.2	0.7	2
4131124DP04	1/2"	15	16	0.4	0.35	0.8	2.5	0.4	0.35	0.7	2
4131124DP063	1/2"	15	16	0.63	0.56	0.8	2.5	0.63	0.56	0.7	2
4131124DP1	1/2"	15	16	1	0.86	0.8	2.5	1	0.86	0.7	2
413134	3/4"	20	16	2.8	1.8	0.7	1.5	2.5	1.6	0.5	1
413134P	3/4"	20	16	2.8	1.8	0.7	1.5	2.5	1.6	0.5	1
4131344DP4	3/4"	20	16	4	1.8	0.7	1	4	1.6	0.5	0.8
4131344DP	3/4"	20	16	2.8	1.8	0.7	1.5	2.5	1.6	0.5	1



Specification

- Connection Type: Threaded, Male

Typical Application

- Fan Coil Units, Chilled water & HVAC system

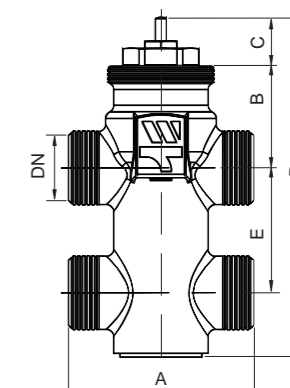

Characteristic Curve

Nominal Diameter 15mm (1/2")

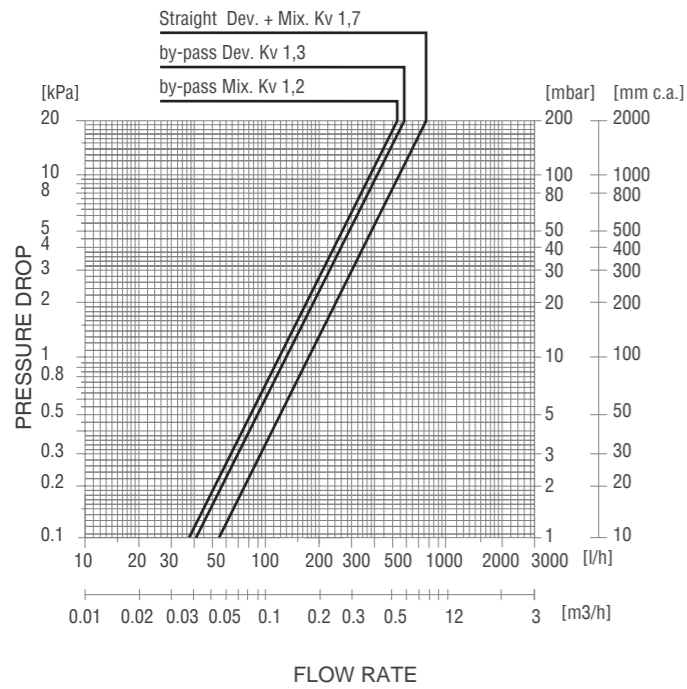

Nominal Diameter 20mm (3/4")

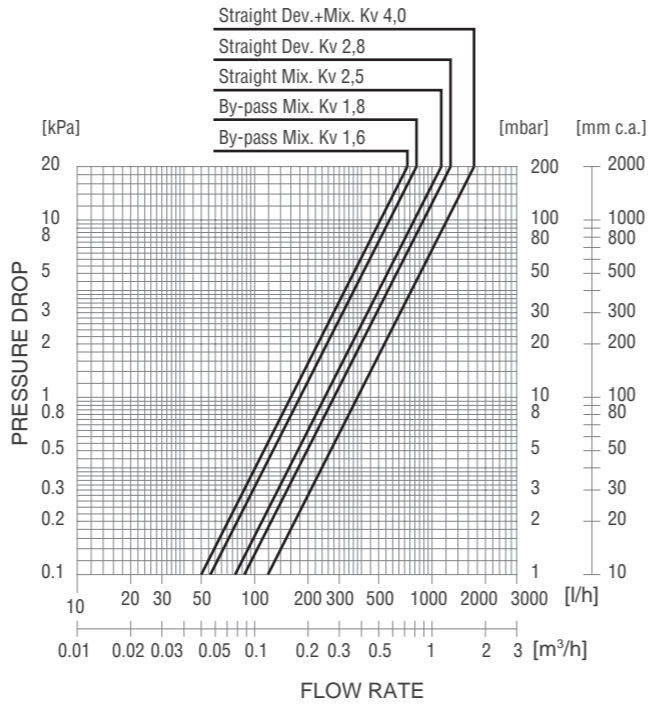

Nominal Diameter 15mm (1/2")-Reduced Kv

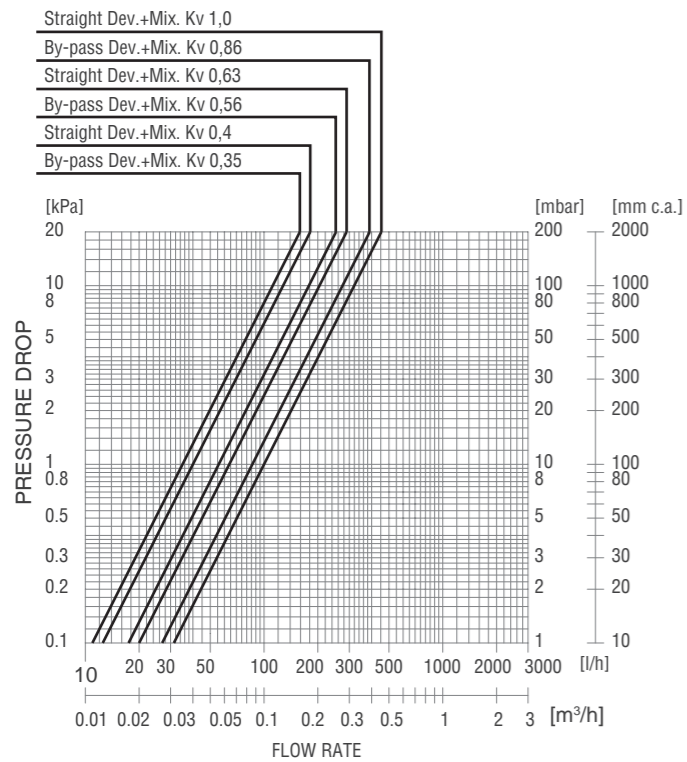

Series EMUJC

Electronic Modulating Actuator

The actuator EMUJC Series is an electronic device with 3-point or proportional control signal (see technical features). It is distinguished by its compact footprint, which makes installation in small spaces possible; the actuator can be easily coupled with compatible valve bodies (2131-3131-4131, DYN Series) without any hydraulic operations (system drainage). The actuator's operating status (On, Off, End stroke) is clearly indicated by a LED.

Features

- Diagnostics of actuator operating status by means of LED: On-Off, End stroke reached, in-progress stroke positioning
- Cable length: 2m. Nominal thrust: 120N
- Degree of protection: IP43. Ambient temperature: 0÷50°C

Installation Dimensions

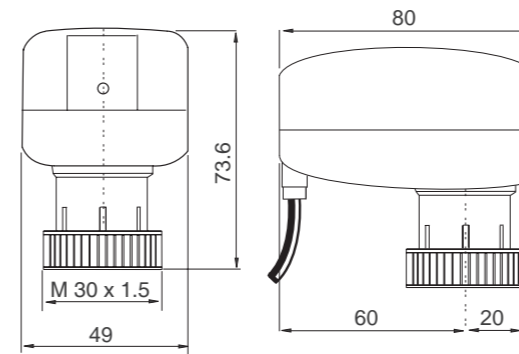

Specification

- Design Standard: compliant with LVD2014/35/EU, EMC 2014/30/EU



Technical Specification

Model	EMUJC-010	EMUJC-24	EMUJC-230
Action/Control	proportional	2 and 3 points	2 and 3 points
Power supply	50/60Hz-24 Vac ±15%	50/60 Hz-24 Vac ±15%	50/60 Hz - 230 Vac ±15%
Control signa	0÷10 Vdc (1) , 2÷10 Vdc 0÷5 Vdc, 5÷10 Vdc 0÷20 mA, 4÷20 mA	24 Vac	230 Vac
Impedance (power signal)	power: >100 kΩ current: 500 kΩ	-	-
Power consumption	2,5 VA (2) 1,5 W (3)	2,5 VA ⁽²⁾ 1,5 W ⁽³⁾	6,5 VA ⁽²⁾ 2,2 W ⁽³⁾
Electrical protection	IP43	IP43	IP43
Stem stroke	3,2 (1) - 4,3 - 5,5 mm	Max 6,3 mm	Max 6,3 mm
Nominal thrust	120 N +30% - 20%	120 N +30% - 20%	120 N +30% - 20%
Stroke time	8 seconds	13 s/mm	13 s/mm
Operating status	Bi-coloured LED green/red	green LED	green LED
Coupling ring nut	M30x1,5	M30x1,5	M30x1,5
Electric cable	3x0,35 mm -2 meters	3x0,35 mm ² -2 meters	3x0,75 mm ² -2 meters
Ambient temperature	0÷50°C	0÷50°C	0÷50°C
Storage temperature	-20÷65°C	-20÷65°C	-20÷65°C
Operating humidity and storage	Non-condensing	Non-condensing	Non-condensing
Temperature of fluid	Min 0°C Max 95°C	Min 0°C Max 95°C	Min 0°C Max 95°C
Noise level	< 30 dB(A)	< 30 dB(A)	< 30 dB(A)
Material:			
• housing	ABS + PC	ABS + PC	ABS + PC
• stem	PA66, 30% glass filled	PA66, 30% glass filled	PA66, 30% glass filled
• ring nut	Nickel-plated brass	Nickel-plated brass	Nickel-plated brass

Note: (1) Factory setting, (2) Apparent, (3) Active

Operation

The operation of the EMUJC Series actuator is based on the rotation of a shaft driven in either direction by a set of gears. The latter are, in turn, driven by a bidirectional synchronous motor through a magnetic coupling which limits the torque transmitted and therefore also the linear output force. The actuator and valve body (Fig.1) are coupled by means of a threaded ring nut. The movement of the actuator is transmitted to the stem of the valve by axial contact and is kept constant by means of a spring situated inside the valve body. In this way, the valve opening and closing forces are obtained, in one direction, through the thrust exerted by the actuator (Fs opens way B-AB, Fig.2) and, in the other direction, through the force of the spring (Fm opens way A-B, Fig.2) situated inside the valve itself. The valve remains open if the actuator is removed from the valve body.

Actuator - valve coupling by means of threaded ring nut

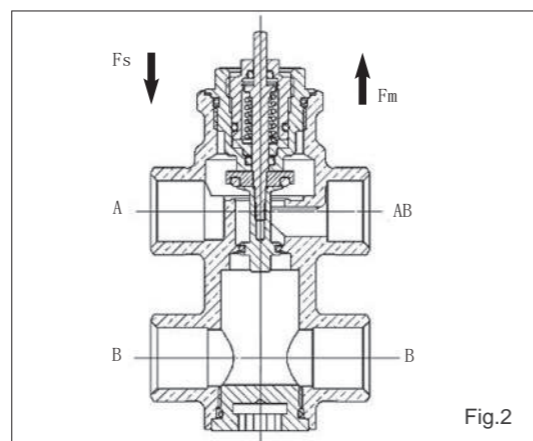

Models with three-point control (EMUJC-230 and EMUJC-24)

Action
When the actuator is powered between terminals 1 and 2, the stem extends. When power is removed, the actuator remains in position. When the actuator is powered between terminals 1 and 3, the stem retracts and when the signal is removed, the actuator remains in position. On the other hand, if the actuator remains powered, it stops automatically about 90 seconds after reaching the end stroke position.

Action	EMUJC-230 cable colour	EMUJC-24 cable colour	Stem movement
terminal 1 terminal 2	Blue Brown	Black Red	The stem extends
terminal 1 terminal 3	Blue Orange	Black Orange	The stem retracts

End stroke
If the signal is continuously applied in the same direction, every 2 hours the actuator starts up for about 90 seconds (in keeping with the signal direction applied), to confirm the end stroke position.

Check of operating status
Models with three-point control are fitted with green LEDs to indicate the operating status:

LED	Signal	Meaning
	Off	Actuator not powered
	Flashing green	Stem moving or Confirmation of end stroke position
	Steady green	End stroke position reached

Model with proportional control (EMUJC-010)

Action
When the control signal increases (from 0 to 10 V) in Direct Action (DA) configuration the stem extends, and in Reverse Action (RA) configuration, the stem retracts.
When the control signal decreases (from 10 to 0V) in Direct Action (DA) configuration the stem retracts, and in Reverse Action (RA) configuration, the stem extends

Action	Control signal	Stem movement
Direct Action (DA)	0÷10 Vdc	The stem extends
	10÷0 Vdc	The stem retracts
Reverse Action (RA)	0÷10 Vdc	The stem retracts
	10÷0 Vdc	The stem extends

End stroke
If the signal is continuously applied in the same direction, every 2 hours the actuator starts up for about 60 seconds (in keeping with the signal direction applied), to confirm the end stroke position.

Self-calibration
When it is powered, the actuator self-calibrates its end stroke position. The actuator drives the stem out for the whole available stroke of the valve until it no longer detects movement of the plug and it memorises its position. At the end of the self-calibration cycle, the actuator positions the stem according to the control signal.

Control signals
The actuator is set up to receive the following user-selected input control signals:

- 0÷10 Vdc
- 2÷10 Vdc
- 0÷5 Vdc
- 5÷0 Vdc
- 0÷20 mA
- 4÷20 mA

Check of operating status
The model with proportional control is fitted with a bi-coloured LED (green/red) to indicate the operating status:

LED	Signal	Meaning
	Off	Actuator not powered
	Flashing green	Stem moving or Confirmation of end stroke position
	Steady green	Position reached
	Flashing red	Self-calibration cycle
	Steady red	No input signal (when set at 2÷10V o 4÷20 mA)

Installation

- Take the precautions below to install the EMUJC Series electronic actuators:
1. Position the actuator above the valve and manually screw on the ring nut (Fig.3). Do not use tools that could damage the actuator.
 2. Make sure there is enough room for assembly and disassembly (Fig.4).
 3. Install vertically or horizontally, making sure the actuator is at an angle of less than 90° (Fig.5), because any leakage from the valve could cause irreparable damage to the actuator.
 4. Do not cover the actuator with insulating material to avoid overheating.
 5. Never use the actuator as leverage to assemble the valve.

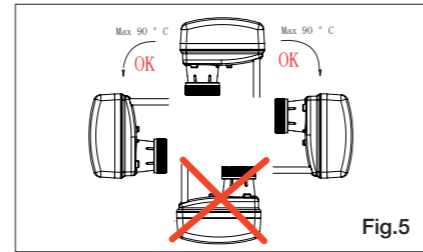
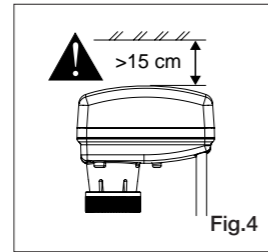
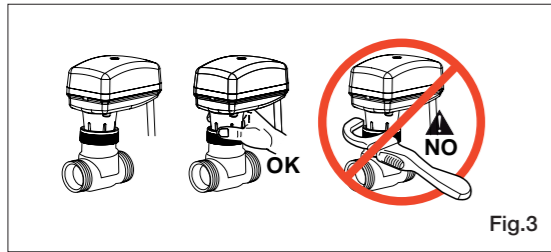

Electrical wiring

When wiring the EMUJC Series electronic actuators, take the following precautions:

1. Electrical wiring must be done by authorised personnel, in compliance with the laws of the country of installation.
2. Mains voltage and low voltage must be powered separately.
3. Make sure the power supply conforms with the actuator voltage.
4. Before switching on, check all the wiring connections.
5. Short-circuited or improperly connected wires could cause permanent damage to the appliance.
6. The colours of the wires may change so always refer to the wiring diagrams shown on the cover of each actuator.

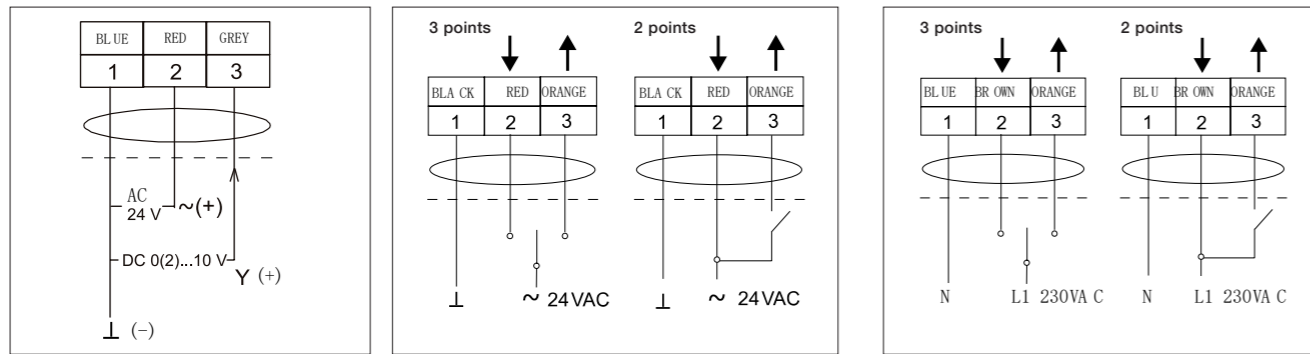

Configuration

The actuators with 2 and 3 points control (EMUJC-24 and EMUJC-230) do not need any initial set-up. The proportional actuator (EMUJC-010) can be configured on the basis of the input signal, the desired action and the required stem stroke. The main configurations are shown below. For more information refer to the instruction sheet.

DIP SWITCH		ON	OFF
<input type="checkbox"/> 0.10VDC	<input type="checkbox"/> 0.5VDC	<input type="checkbox"/> 5.10VDC	<input type="checkbox"/> 2.10VDC
<input type="checkbox"/> 0.20mA	<input type="checkbox"/> 1.0VDC	<input type="checkbox"/> 4.20mA	<input type="checkbox"/> 4.20mA
<input type="checkbox"/> DA	<input type="checkbox"/> RA	<input type="checkbox"/> LIN	<input type="checkbox"/> Eq%
<input type="checkbox"/> VDC	<input type="checkbox"/> mA		
1: RANGE	4: ACTDN		
2: COMMAND	5: CURV E		
3: SIGNAL	6: SIGNAL TYPE		

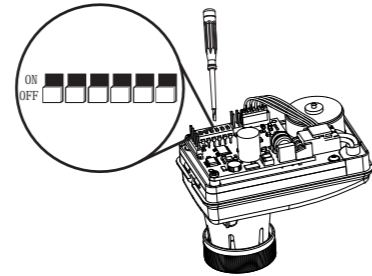

Dip switch

Switches 1-2-3

Switches for setting the control signal. Switch 6 must be selected as a consequence.

Switches 4

Switch for setting the actuator action: DA = Direct Action, RA = Reverse Action.

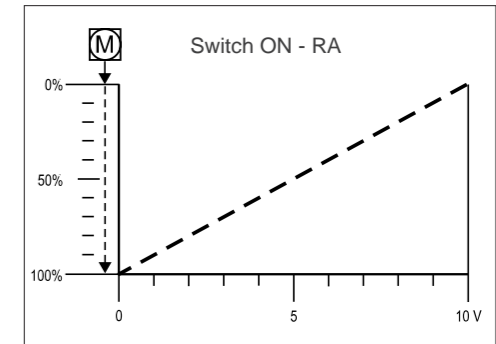
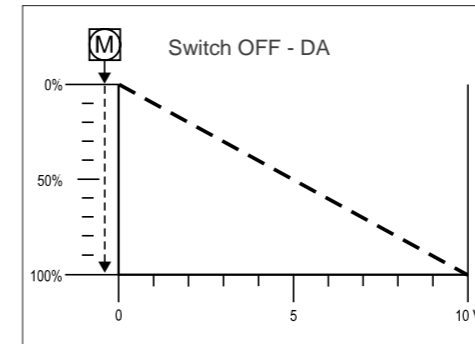

Switches 5

Switch for setting the control characteristics.

Switch OFF = linear output to use with linear or equal percentage valves.

Switch ON = pseudo equal percentage output to use with quick-opening or on/off valves.

Switches 6

Switch for setting the type of control signal.

Switch OFF = signal voltage

Switch ON = signal current

This switch must be set on the basis of switches 1, 2 and 3

NOTE: all switches are factory set in the OFF position.

Jumper

The correlation between the positions of the jumper and the stroke of the actuator stem is shown below.

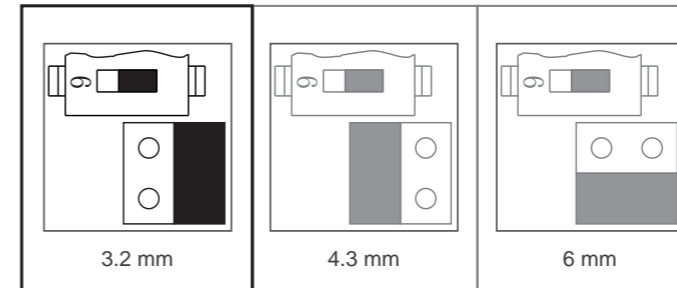

NOTE: the stroke is factory set at 3.2mm

Overall dimensions (mm)

EMUJC

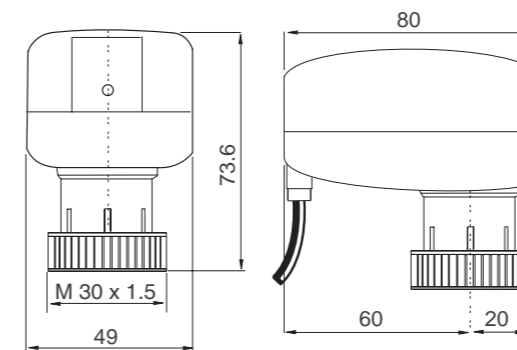

Series 22C

ON/OFF Electrothermic Actuators

The electrothermic actuators 22C, 22CX, 22CX5 and 26LC Series are ON/OFF devices used for automatic actuation of the valves on thermostatic adaptable valves, fan coil valves, manifolds.

Features

- NO (normally open), NC (normally closed)
- 2-wire or 4-wire (with auxiliary microswitch), both easy to fix on the valve body with a M30x1,5 threaded ring nut
- The use of electrothermic actuators instead of pure thermostatic actuators allows remote control. The room thermostat or control component controlling the system can be positioned in the most suitable point of each room to provide regulation and wired back to the electrothermic control head

Technical Characteristics

	22C	22CX	22CX5	26LC
Action	ON/OFF	ON/OFF	ON/OFF	ON/OFF
Type of movement	Linear	Linear	Linear	Linear
Power supply	24-230 V a.c./d.c. (+10%/-15%)	24-230 V a.c./d.c. (+10%/-15%)	24-230 V a.c./d.c. (+10%/-15%)	24-230 V a.c./d.c. (+10%/-15%)
Frequency	50 ÷ 60 Hz	50 ÷ 60 Hz	50 ÷ 60 Hz	50 ÷ 60 Hz
Power consumption (continuous duty)	1,8 W (230V) 1,6 W (24V)	1,8 W (230V) 1,6 W (24V)	1,8 W (230V-24V)	1,8 W (230V) 1,6 W (24V)
Initial opening time (NC) or closing time (NO) (230V) (Power on) 230V.	75 s.	75 s.	70 s.	75 s.
Final opening time (NC) or closing time (NO) (230V) (Power on) 230V.	3 min.	3 min.	5 min.	3 min.
Initial opening time (NC) or closing time (NO) (230V)(Power on) 24V.	3 min.	3 min.	95 s.	3 min.
Final opening time (NC) or closing time (NO) (230V) (Power on) 24V.	5 min.	5 min.	6 min.	5 min.
Actuator stroke	max 3,5mm	max 3,5mm	max 5mm	max 3,5mm
Auxiliary microswitch not energized (4-pole model)	max 700 (3A) mA - 250 V a.c.	max 700 (3A) mA - 250 V a.c.	max 700 (3A) mA - 250 V a.c.	max 700 (3A) mA - 250 V a.c.
Protection class	IP44 in vertical position to EN60529	IP54 to EN60529	IP54 to EN60529	IP64 to EN60529
Electrical Protection class	Class II	Class II	Class II	Class II
Pollution rating	Grade 2	Grade 2	Grade 2	Grade 2
Nominal closing force (power OFF)	110 N (±10%) (NC) 80N (±10%) (NO)	110 N (±10%) (NC) 80N (±10%) (NO)	110 N (±10%) (NC)	110 N (±10%) (NC)
Operating temperature range	0÷50°C	0÷50°C	0÷50°C	0÷50°C
Storage temperature limit	-25÷60°C	-25÷60°C	-25÷60°C	-25÷60°C
Fluid temperature limit	110°C	110°C	110°C	110°C
Plastic cover	Polyamide +30F.V. flame retardant RAL 9016	Polyamide +30F.V. flame retardant RAL 9016	Polyamide +30F.V. flame retardant RAL 9016	ABS V0 flame retardant RAL 9016
Electrical cable	2-pole x 0,75mm2 - 1m length* 4-pole x 0,75 mm2 - 1 m length*	2-pole x 0,5mm2 - 1m length*4-pole x 0,5 mm2 - 1 m length*	2-pole x 0,5mm2 - 1m length*4-pole x 0,5 mm2 - 1 m length*	2-pole x 0,5mm2 - 1m length*4-pole x 0,5 mm2 - 1 m length*
Valve connection	Threaded ring nut M30x1,5	Threaded ring nut M30x1,5	Threaded ring nut M30x1,5	Threaded ring nut M30x1,5

* Special cable length on request

Reliability of the electrothermic actuators 22C, 22CX, 22CX5 and 26LC Series is guaranteed due to 100% testing of the production.



Application

The electrothermic actuators 22C, 22CX, 22CX5, 26LC Series are used for ON/OFF control of the heat emission of terminal control units in heating and air conditioning systems, through an electric signal transmitted by a thermostat.

The use of electrothermic actuators instead of pure thermostatic actuators allows remote control. The room thermostat or control component controlling the system can be positioned in the most suitable point of each room to provide regulation and wired back to the electrothermic control head.

Operation

Operation of the electrothermic actuators 22C, 22CX, 22CX5, 26LC Series is powered by on a wax thermostatic element assembled into in the actuators and activated by a PTC thermistor against a signal sent by a room thermostat or timing thermostat.

When the thermostatic element expands, it supplies the thrust required for the movement of the valve. The 4-wire version is provided with an auxiliary contact for additional features (metering, control of pump, fan or other equipment). The actuator has a transparent zone that allows for checking the status of the actuator (only for 22C, 22CX and 22CX5 Series)

Red = valve closed - Black = valve open.

About the 26LC Series, for using with devices that have an electrical consumption higher than microswitch limits, use an additional relay. Two LEDs (visible only when lighted) are positioned on top of the actuator: the green LED shows the power supply presence and the blue LED shows when the valve is open.

Installation

Electrothermic actuators 22C, 22CX, 22CX5, 26LC Series can be selected according to the type of system, installation space and power supply. In systems with 2-way control valves fitted with electrothermic actuators it is advisable to install by-pass valves in (466 Series or USVR Series) to ensure a minimum recirculation of the mean.

Mounting

To install the actuators follow these steps:

1. remove the protective cap, if present, or handwheel from the valve (or manifold outlet)
2. screw-in the actuator ring nut by hand on the threaded part of the valve body and lock it
3. connect the wires to the power supply
4. insert the plug in the actuator connector (only for 26LC Series)

Maintenance

Do not remove the cable. Opening the 22C, 22CX, 22CX5, 26LC Series actuator will cause irreparable damage to the device. Faulty actuators must be replaced as complete sets.

Warning 22C Series.
The actuator has an degree of protection IP44 in vertical position.

Warning 22CX, 22CX5 Series.
IP54 is installed in any position respect to the valve body.

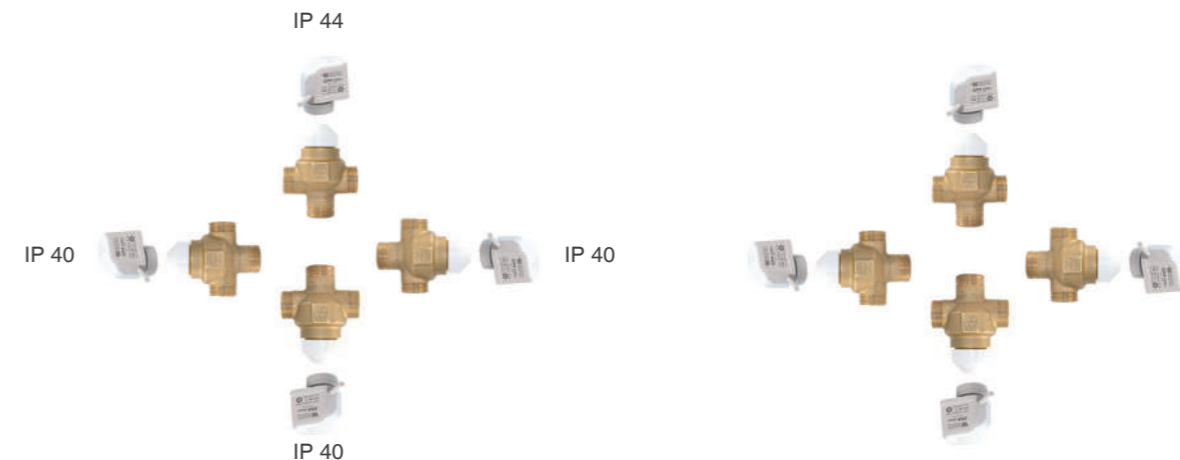



22C-EN-202212

Warning 26LC Series.
Protection class IP64 allows to install the 26LC in any position respect to the valve body.

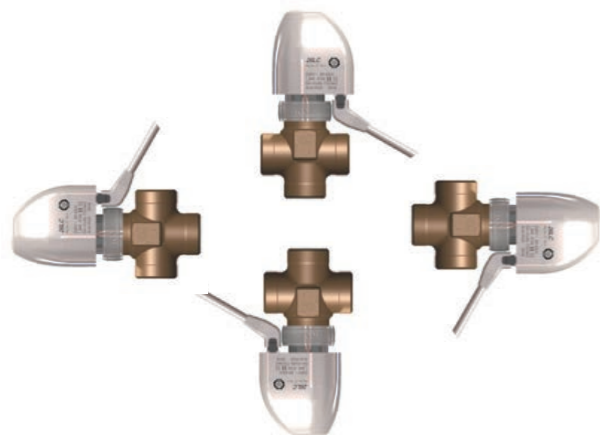

The removable cable allows easy mounting, maintenance and replacing. Pull the connector pressing the safety latch to take it out from the socket.



Electrical wire connections

22C-22CX-22CX5-26LC 2-wires

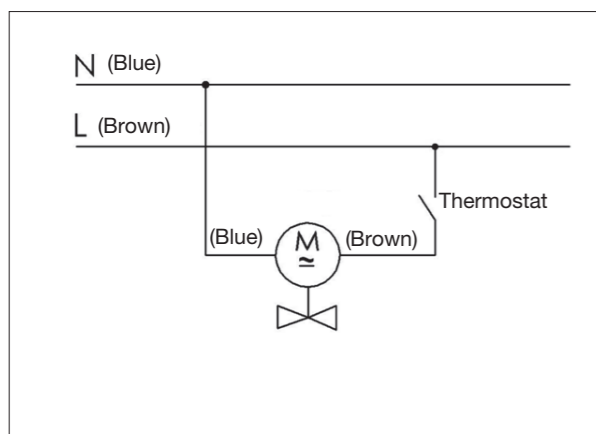

22C-22CX-22CX5-26LC 4-wires

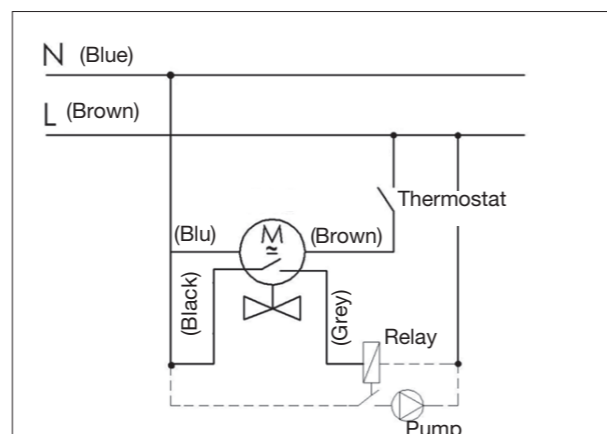

Overall dimensions (mm)

22C

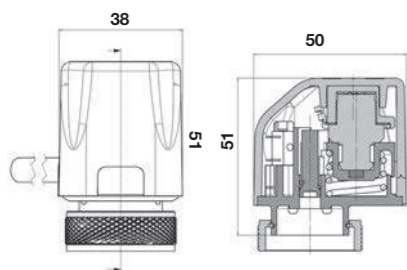

22CX-22CX5

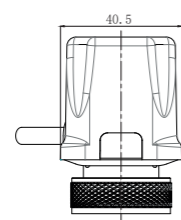

26LC

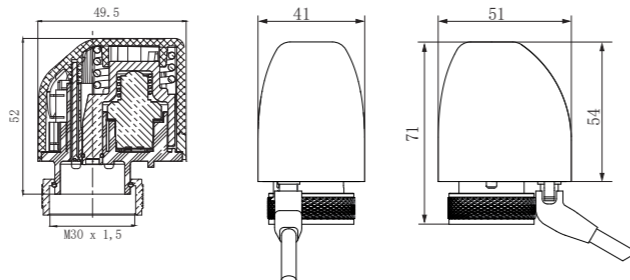

STBV-25/ 25N-EN-202206

Series STBV-25/ 25N

Fixed Orifice Double Regulating Valve

Size: DN15-DN50

The Watts STBV-25 Static Balancing Valve is designed for flow balancing in cooling, heating or process water systems. Its fixed orifice measuring points enable convenient and accurate system commissioning.



Features

- Accurate flow control
- Numerical indicator of opening degree on the hand wheel
- Self-sealing measuring points to protect against leakage
- Integral fixed orifice and test points
- Shut-off function for troubleshooting or maintenance

Pressure-Temperature

- Nominal Pressure: PN25
- Temperature Range: 0 °C ~120 °C

Test Pressures

Pneumatic	Hydraulic
Shell: 6 bar	Shell: 37.5 bar
Shell: 6 bar	Seat: 27.5 bar

Material

NO.	Component	Material
1	Body	Bronze
2	Disc Face	DZR Brass (DN15-DN20) PTFE (DN25 – DN50)
3	Orifice Plate	DZR Brass
4	Nut	DZR Brass
5	Disc	DZR Brass
6	Disc Retaining Ring	DZR Brass
7	O Ring	NBR
8	Bonnet	DZR Brass (DN15-DN32) Bronze (DN40- DN50)
9	Stem	DZR Brass
10	Retainer Ring	Stainless Steel (SS304)
11	Sleeve	Brass
12	Screw	Brass
13	Hand Wheel	PA
14	Cap	PA
15	Screw	Stainless Steel (SS304)
16	Test Point	DZR Brass

Installation Dimensions

DN	A	B	C	Weight(kg)	Flow	KV
DN15	87	105	10	0.528	1.72	2.2
DN20	96	106	13.7	0.585	2.97	4.6
DN25	100	127	17.4	0.812	4.75	8.5
DN32	114	128	24.6	1.021	10.25	16.7
DN40	125	143	31.8	1.447	16.83	26.1
DN50	146	144	38.9	2.003	27.26	43.2

Specification

- Design standard: BS7350
- Connection Standard: Threaded to ISO 7-1/ASME B1.20.1
- Test Standard: BS6755
- Medium: water

Approval

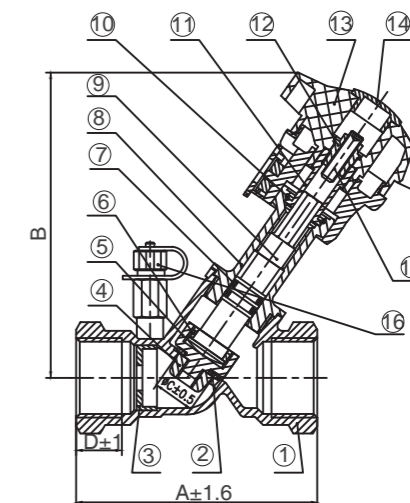

Kv Values/ Position Setting

Setting	DN15	DN20	DN25	DN32	DN40	DN50
1	0.3	0.4	0.7	1.3	2.3	2.79
2	0.6	0.9	1.6	4	5.3	7.5
3	1.2	2.3	2.8	8.5	13.7	20.63
4	1.7	3.3	4.6	10.5	16.8	27.37



Characteristic Curves

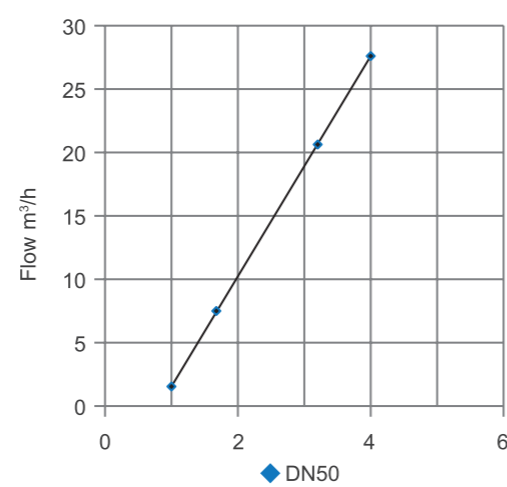
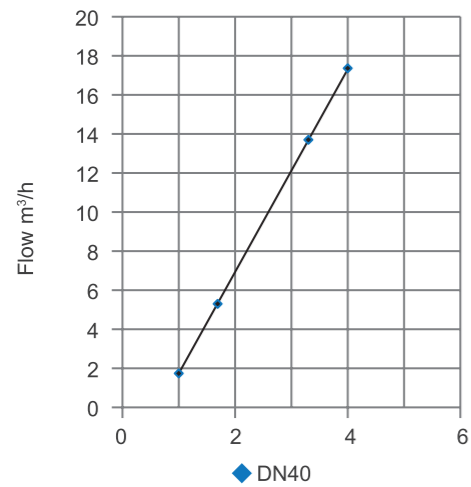
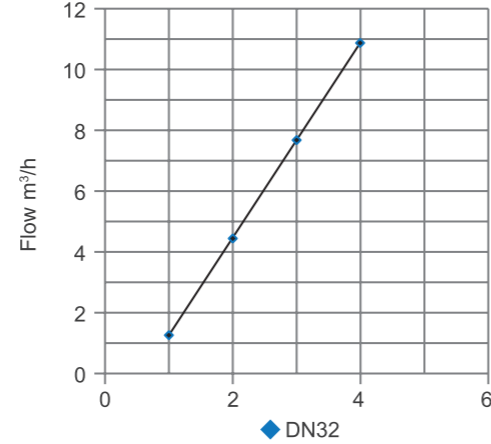
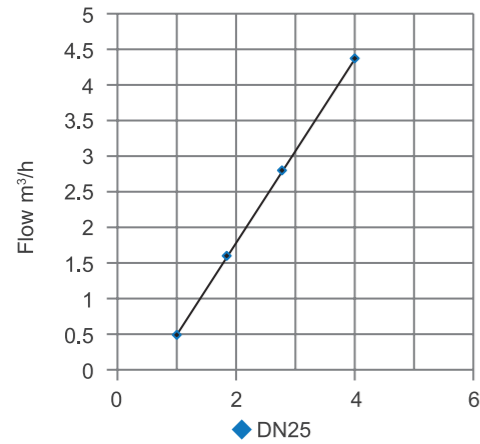
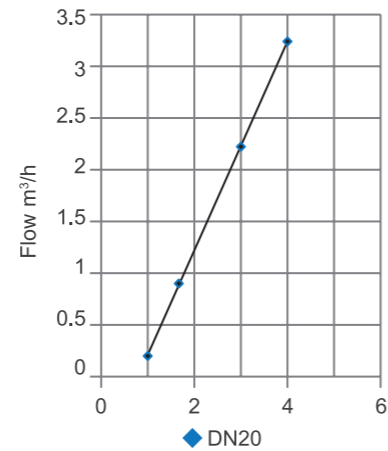
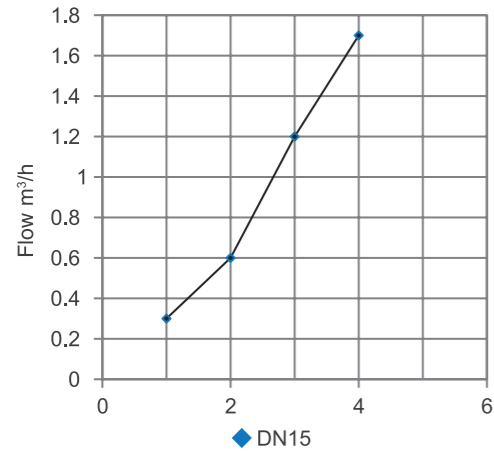

Series W-STBV-16Q

Static Balancing Valve (Variable Orifice)

Size: DN65-DN500

The Series W-STBV static balancing valves are designed for flow balancing in cooling, heating or process water systems. Its measuring points enable convenient system troubleshooting.

Features

- Accurate flow control
- Numerical indicator of opening degree on the hand wheel
- Lockable set position
- Shut-off function for troubleshooting or maintenance
- Using balanced valve core, easy to adjust
- Self-sealing measuring points to protect against leakage
- No-Rising stem, Variable Orifice

Pressure-Temperature

- Nominal Pressure: PN16
- Temperature Range: -10°C~120°C

Test Pressures

Hydraulic
Shell: 24 bar
Seat: 18bar

Material

No.	Component	Material
1	Body	Ductile Iron
2	Core	Bronze(DN65-DN150) Ductile Iron(DN200-DN300) Stainless Steel(DN350-DN500)
3	Seat Sealing	EPDM
4	Stem	Brass(DN65-DN150) Stainless Steel(DN200-DN500)
5	Bonnet	Ductile Iron
6	Core Rod	Stainless Steel
7	Handwheel	Nylon(DN65-DN200) Cast Aluminum(DN250-DN500)
8	Stem Sealing	EPDM(DN65-DN300) PTFE(DN350-DN500)
9	Measuring Orifices	Brass

Installation Dimensions

Size	L(mm)	H(mm)	W(mm)	Weight(Kg)	Kvs
DN65	290	195	185	15.6	94.47
DN80	310	215	200	20.0	137.31
DN100	350	230	220	26.3	211.20
DN125	400	330	250	38.1	330.22
DN150	480	350	285	52.6	408.32
DN200	600	420	340	91.7	759.21
DN250	730	460	405	152.3	1162.44
DN300	850	600	460	230.0	1703.45
DN350	980	595	520	300.0	2115.00
DN400	1100	635	580	413.0	3050.00
DN450	1200	688	640	567.0	3720.00
DN500	1250	745	715	682.0	4180.00



Specification

- Connection Standard: BS EN 1092-2
- Medium: cold and hot water/glycol
- Patent No: ZL 2013 2 0890615.7

Approval

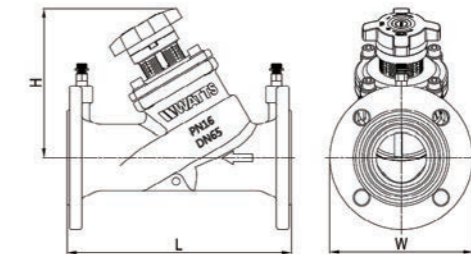
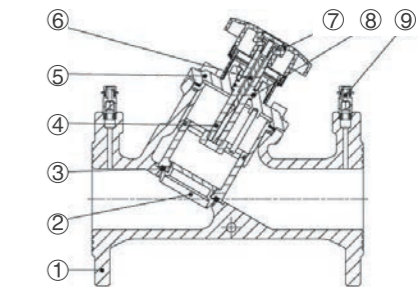

Kv Values

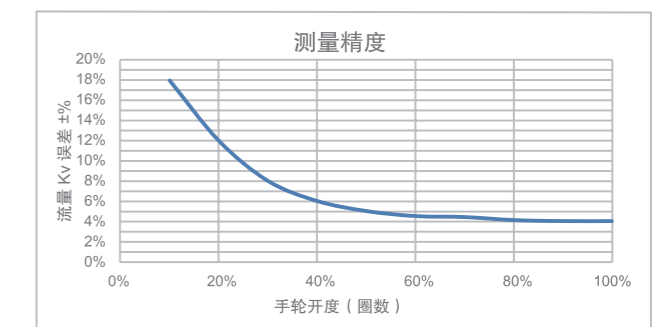



Characteristic Curves

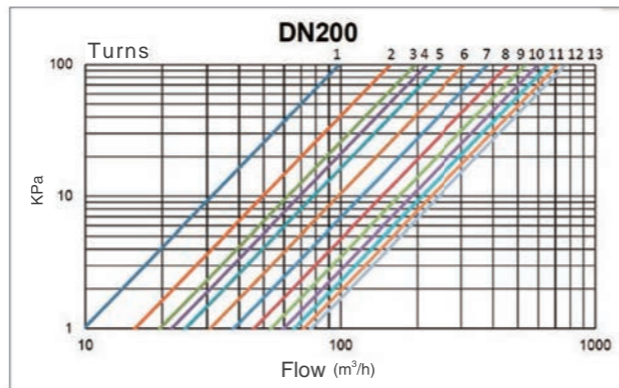
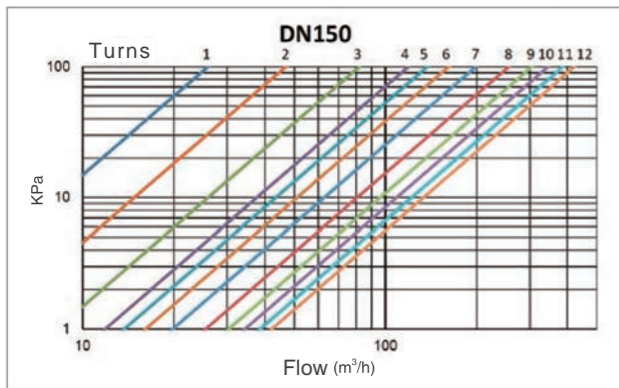
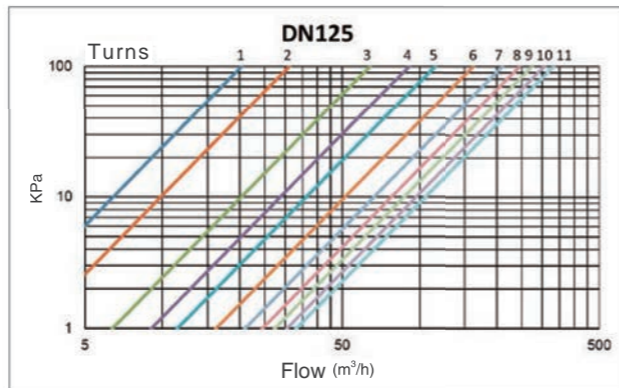
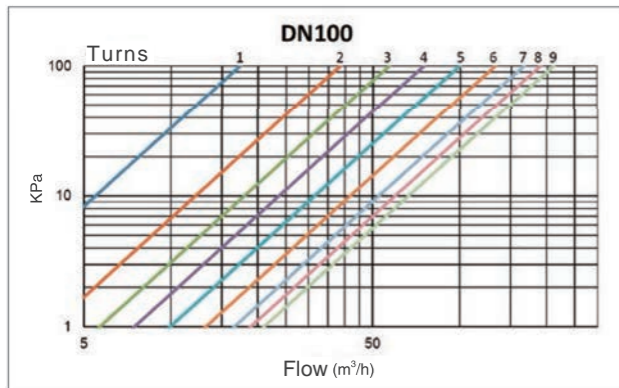
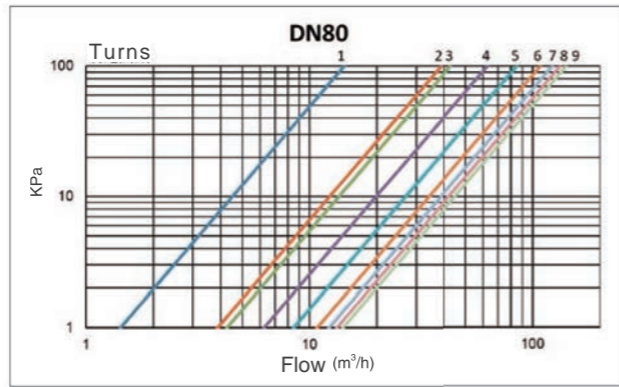
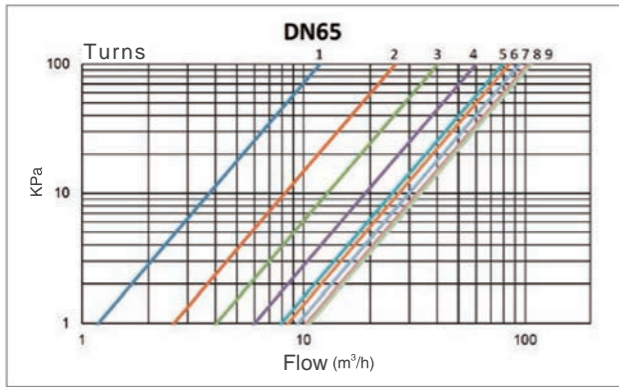

Characteristic Curves

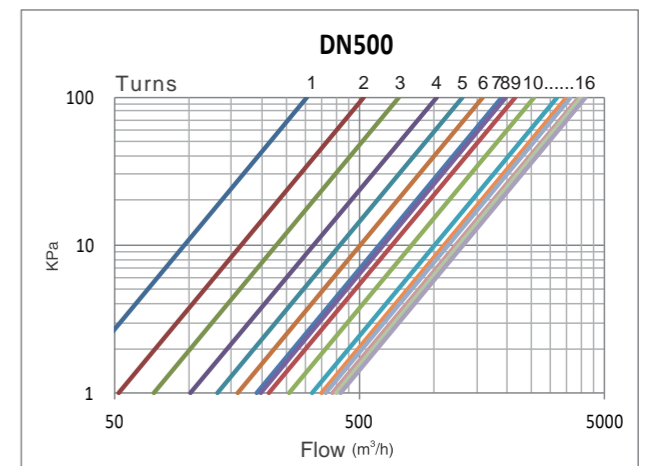
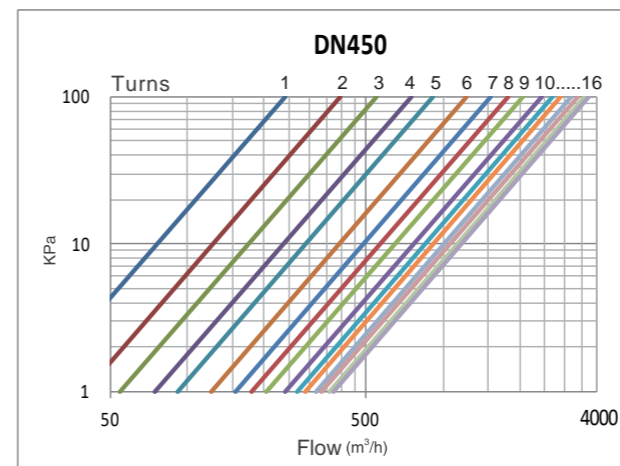
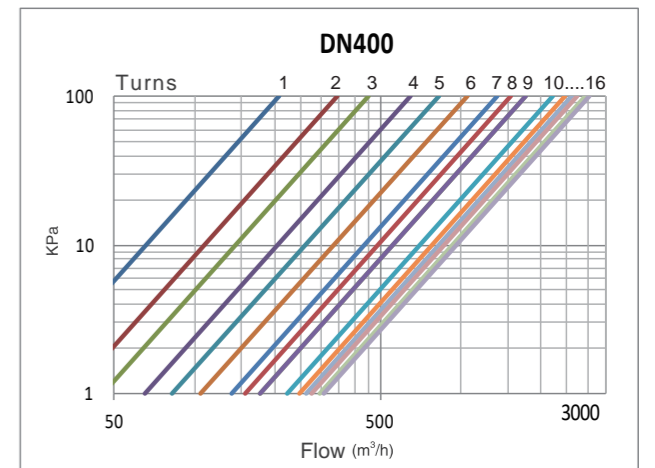
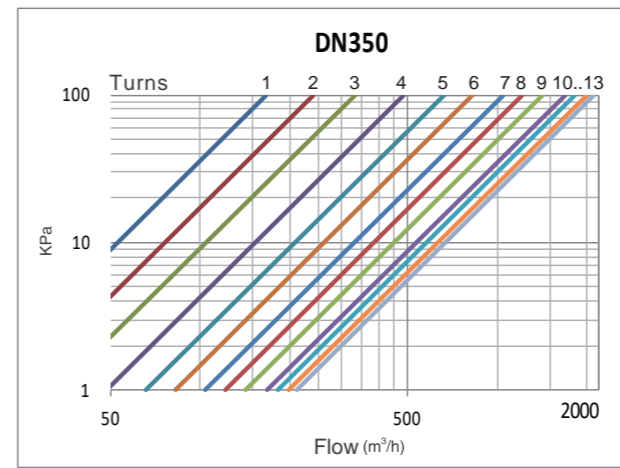
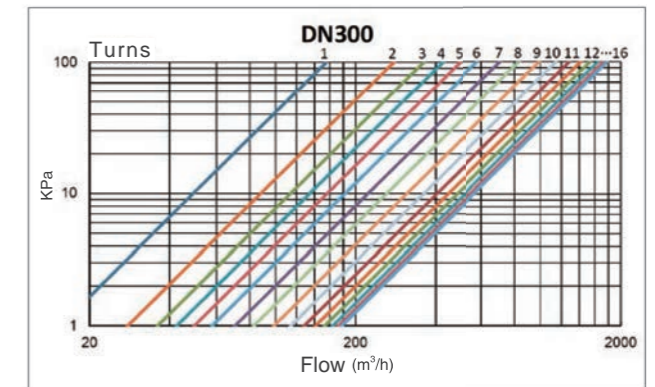
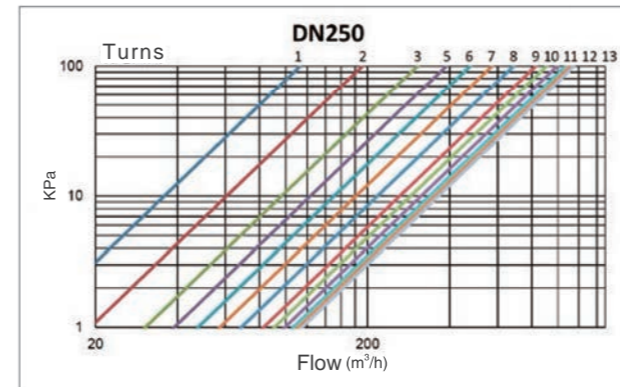



Selection Drawing

For example:

Q: An air conditioning system is equipped with a static balancing valve, with a design flow of 35 m³/h and a pressure drop of 10 kPa. Now we need to select a suitable static balancing valve.

A: As shown in the below model selection line diagram, read out the position point with Q=35m³/h from the left flow scale line, read the position point of 10 kPa from the right pressure drop scale line, connect the two points and the intersection point of Kv value scale line, and make the intersection point of horizontal line and the opening scale line of balance valve of different caliber. The intersection of DN80 intersection point is 6.9 circle, that of DN 100 intersection point is 5.4 circle, that of DN 125 intersection point is 4.8 circle, that of DN150 intersection point is 4.6 circle, and that of DN200 intersection point is 2.25 circle Based on the principle that the setting value is 75%, the DN80 balancing valve is recommended.

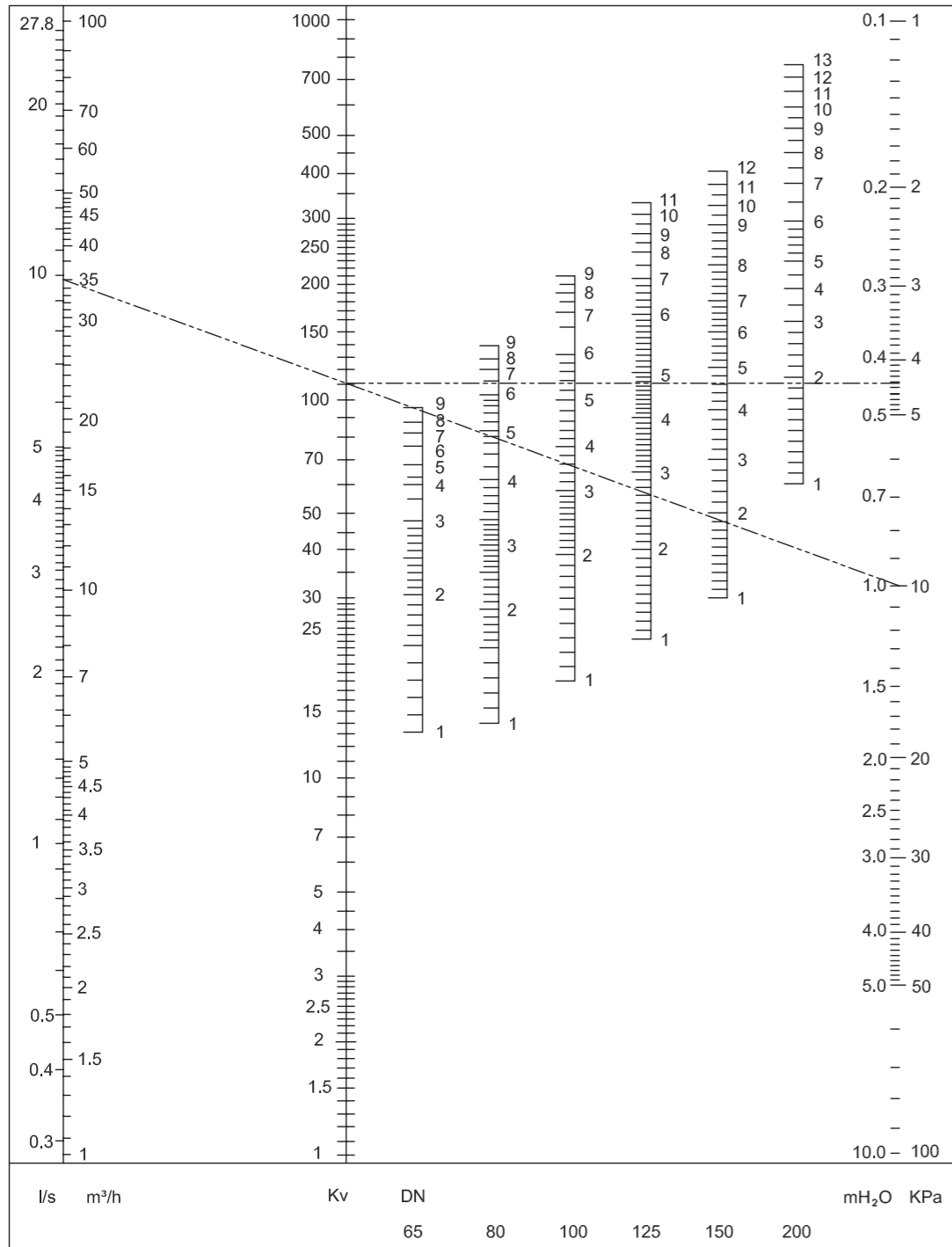

Selection Drawing

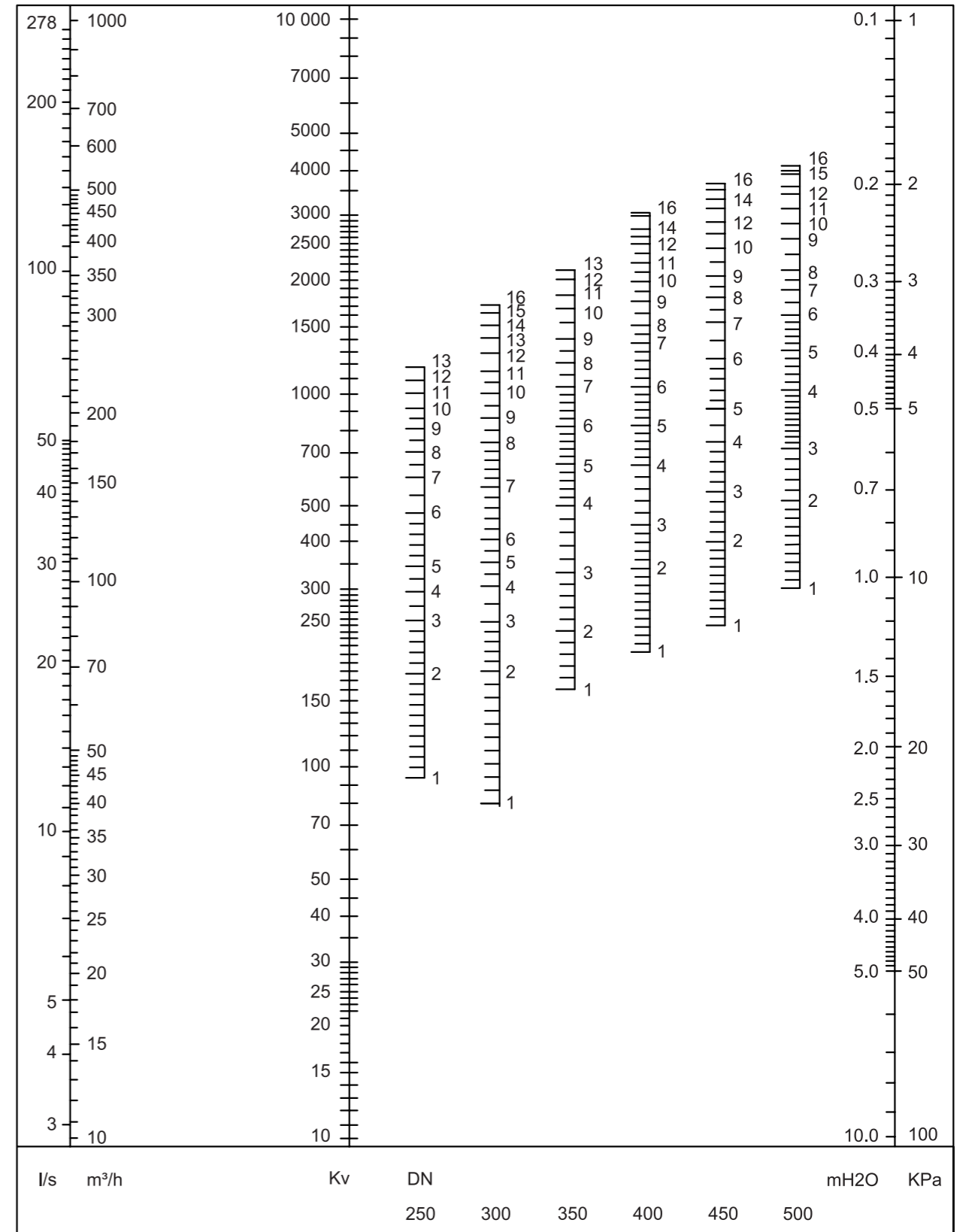



Series W-STBV-25Q

Static Balancing Valve (Variable Orifice)

Size: DN65-DN500

The Series W-STBV static balancing valves are designed for flow balancing in cooling, heating or process water systems. Its measuring points enable convenient system troubleshooting.

Features

- Accurate flow control
- Numerical indicator of opening degree on the hand wheel
- Lockable set position
- Shut-off function for troubleshooting or maintenance
- Self-sealing measuring points to protect against leakage
- Using balanced valve core, easy to adjust
- The hand wheel adopt the die casting aluminum, strong and durable
- The hand wheel wrench connection with energy saving

Material

No.	Component	Material
1	Body	Ductile Iron GGG40
2	Core	Ductile Iron GGG40
3	Seat Sealing	EPDM
4	Shaft Barrel	DN65-150 Brass HPb59-1 DN200-500 Ductile Iron GGG40
5	Stem	Brass HPb59-1
6	Limit Valve Core	Brass HPb59-1
7	Cover	Ductile Iron GGG40
8	Handwheel	DN65-300 Nylon 66 DN350-500 Ductile Iron GGG40
9	Measuring Mouth	Brass HPb59-1



Specification

- Nominal Pressure: PN25
- Working Temperature: -10°C~120°C
- Connection Standard: GB/T 17241.6, ISO7005
- Working Medium: cold and hot water/ethylene glycol

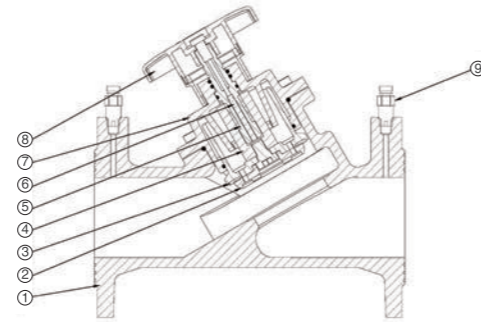

Product Model

Type	Size	Kvs	EDP Code
W-STBV065-25Q	DN65	92.7	61170004
W-STBV080-25Q	DN80	114.5	61170005
W-STBV100-25Q	DN100	187.5	61170006
W-STBV125-25Q	DN125	286.5	61170007
W-STBV150-25Q	DN150	395.0	61170008
W-STBV200-25Q	DN200	758.0	61170009
W-STBV250-25Q	DN250	1102.5	61170010
W-STBV300-25Q	DN300	1516.6	61170011
W-STBV350-25Q	DN350	2115.0	61170012
W-STBV400-25Q	DN400	3050.0	61170013
W-STBV450-25Q	DN450	3720.0	61170014
W-STBV500-25Q	DN500	4180.0	61170015

Product Type

W	WATTS
STBV	Static Balancing Valve
Size	
065-DN65	080-DN80
100-DN100	125-DN125
150-DN150	200-DN200
250-DN250	300-DN300
350-DN350	400-DN400
450-DN450	500-DN500
Pressure	PN25
Body Material	Ductile Iron

Kv Value Curve

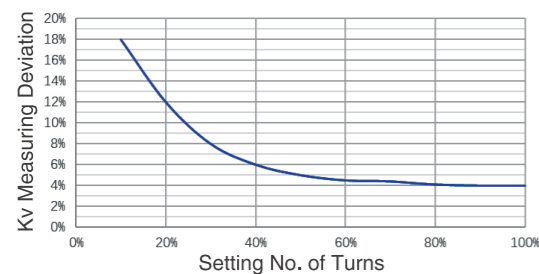

Kvs

Turns	DN65	DN80	DN100	DN125	DN150	DN200	DN250	DN300	DN350	DN400	DN450	DN500
1	15.5	16.3	26.0	22.0	27.9	67.0	109.0	128.0	167.2	208.0	240.5	305.2
2	32.5	32.2	45.0	53.0	54.9	127.0	184.0	211.1	240.0	344.0	396.5	518.0
3	48.7	52.5	59.0	74.0	76.8	191.0	264.0	290.3	330.0	452.0	548.0	724.0
4	58.1	67.5	69.0	96.0	97.6	278.0	356.0	350.6	485.0	651.0	749.0	1024.0
5	64.4	77.2	95.0	125.0	117.2	388.7	438.8	481.2	658.0	824.0	915.0	1315.0
6	69.2	86.2	127.0	156.0	143.2	474.3	538.6	624.2	824.0	1054.5	1242.0	1592.0
7	74.9	96.4	144.5	193.0	186.5	558.7	661.7	731.0	1045.0	1380.0	1541.0	1890.0
8	83.1	104.7	166.5	226.0	225.2	638.1	770.0	886.9	1215.0	1542.0	1792.0	2142.0
9	92.7	114.5	187.5	253.2	265.9	719.5	826.7	1042.1	1420.0	1765.0	2046.0	2586.0
10	-	-	-	286.5	321.5	758.0	920.0	1177.3	1685.0	1980.0	2425.0	2845.0
11	-	-	-	-	362.6	-	1010.0	1330.1	1824.0	2220.0	2680.0	3192.0
12	-	-	-	-	395.0	-	1102.5	1429.1	1988.0	2480.0	2880.0	3480.0
13	-	-	-	-	-	-	-	1516.6	2115.0	2620.0	3180.0	3640.0
14	-	-	-	-	-	-	-	-	-	2750.0	3350.0	3892.0
15	-	-	-	-	-	-	-	-	-	2940.0	3580.0	4024.0
16	-	-	-	-	-	-	-	-	-	3050.0	3720.0	4180.0

Installation Dimensions

Type	B(mm)	K(mm)	D2(mm)	D(mm)	L(mm)	H2(mm)	Weight(Kg)
W-STBV065-25Q	19	145	8-19	185	290	200	15.5
W-STBV080-25Q	19	160	8-19	200	310	210	20
W-STBV100-25Q	19	190	8-23	235	350	246	26
W-STBV125-25Q	19	220	8-28	270	400	256	38
W-STBV150-25Q	20	250	8-28	300	480	286	52
W-STBV200-25Q	22	310	12-28	360	600	460	99
W-STBV250-25Q	24.5	370	12-31	425	730	493	146
W-STBV300-25Q	27.5	430	16-31	485	850	535	200
W-STBV350-25Q	30	490	16-34	555	980	595	321
W-STBV400-25Q	32	550	16-37	620	1100	635	438
W-STBV450-25Q	34.5	600	20-37	670	1200	688	589
W-STBV500-25Q	36.5	660	20-37	730	1250	745	705

Characteristic Curves

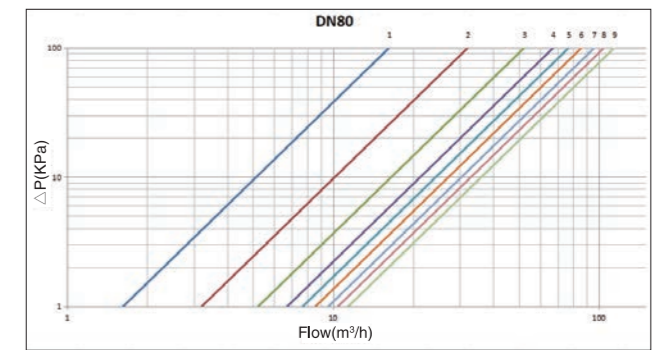
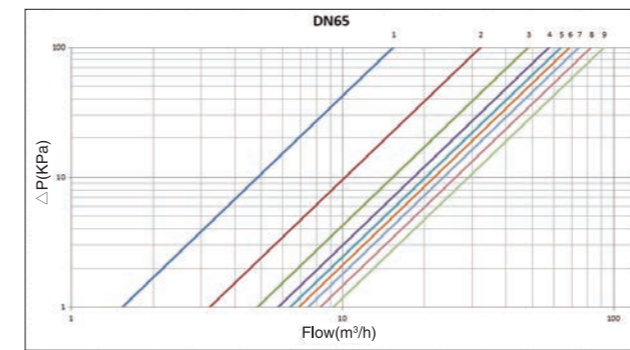



Characteristic Curves

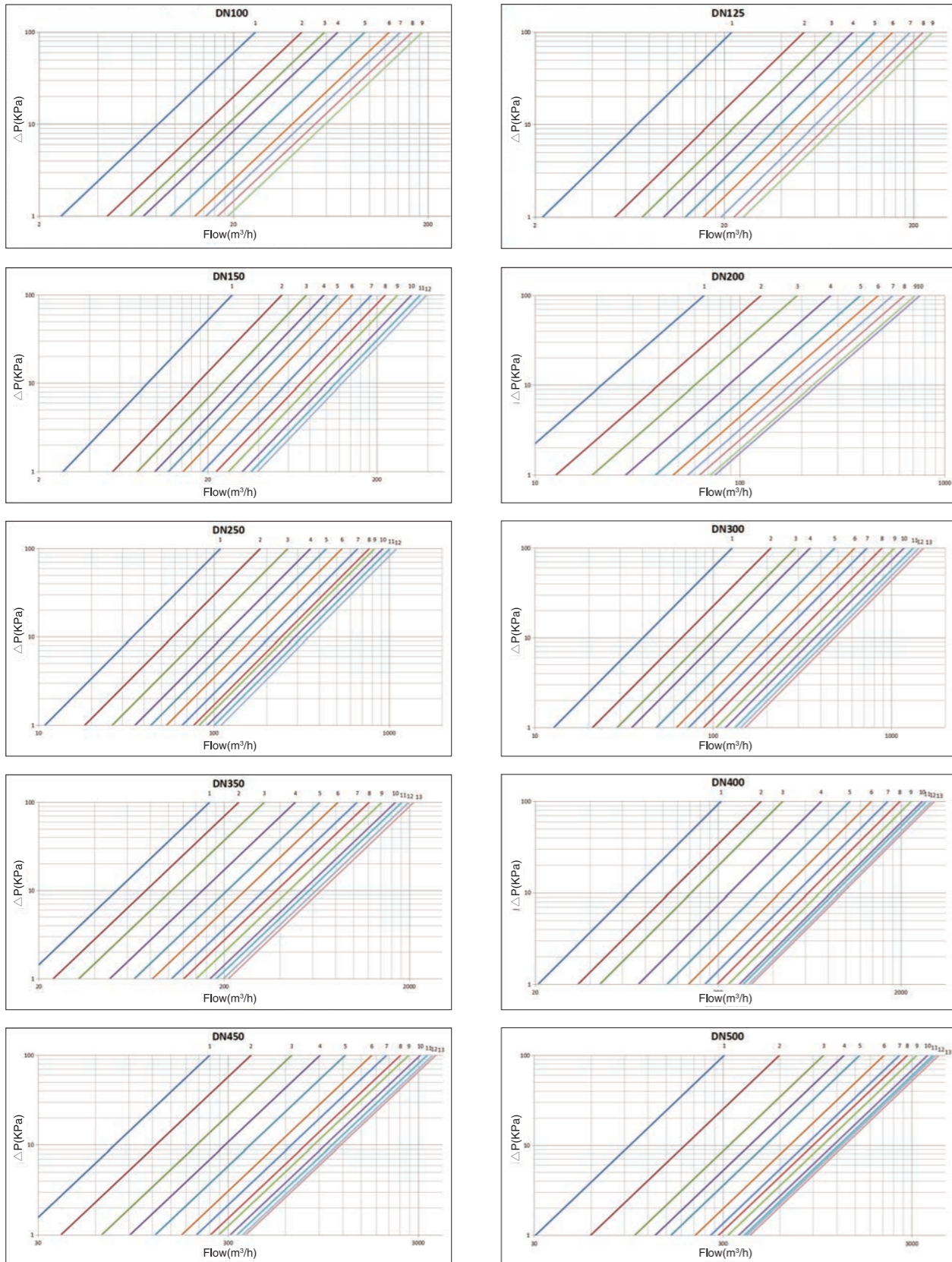

Selection Drawing

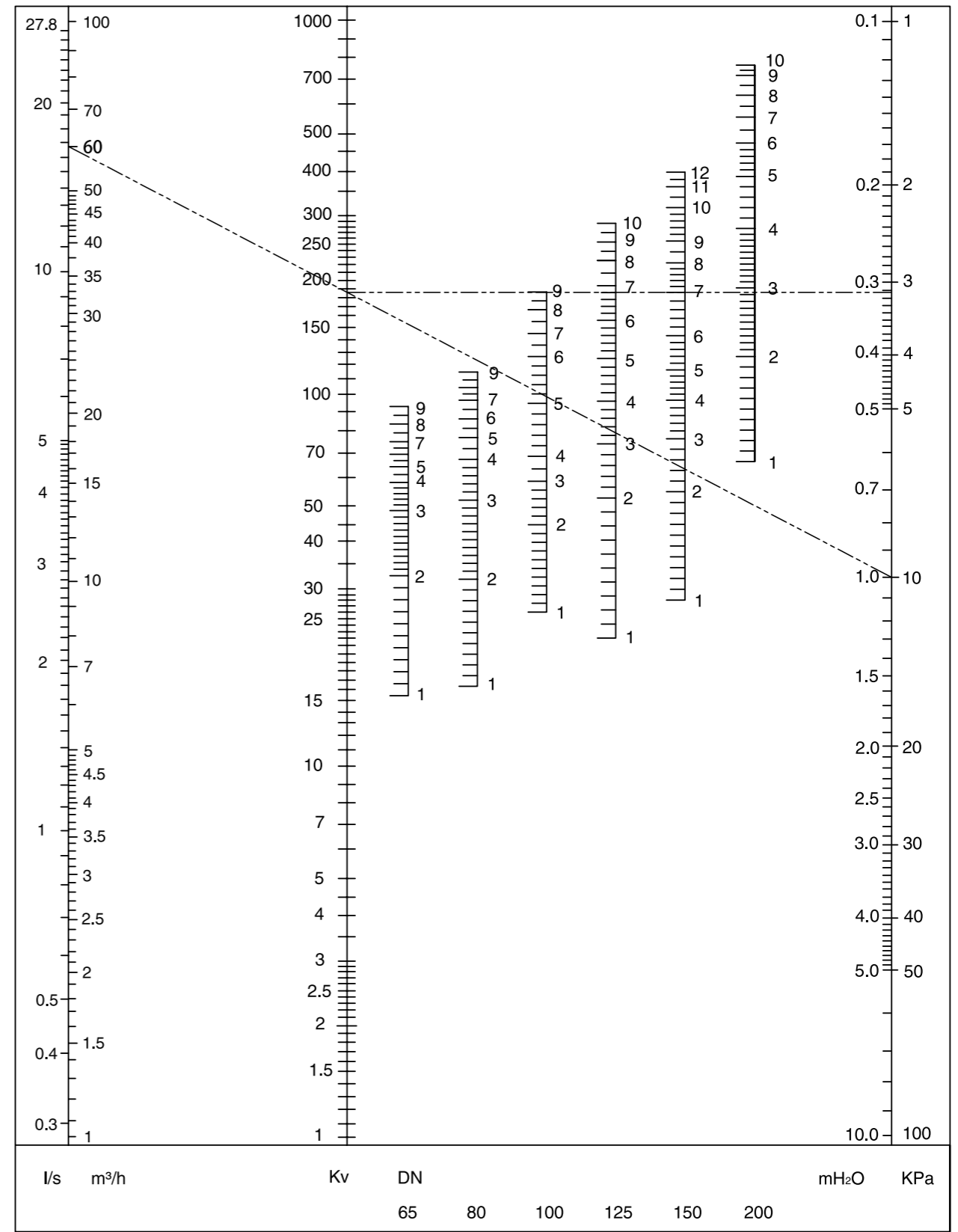

Selection Drawing

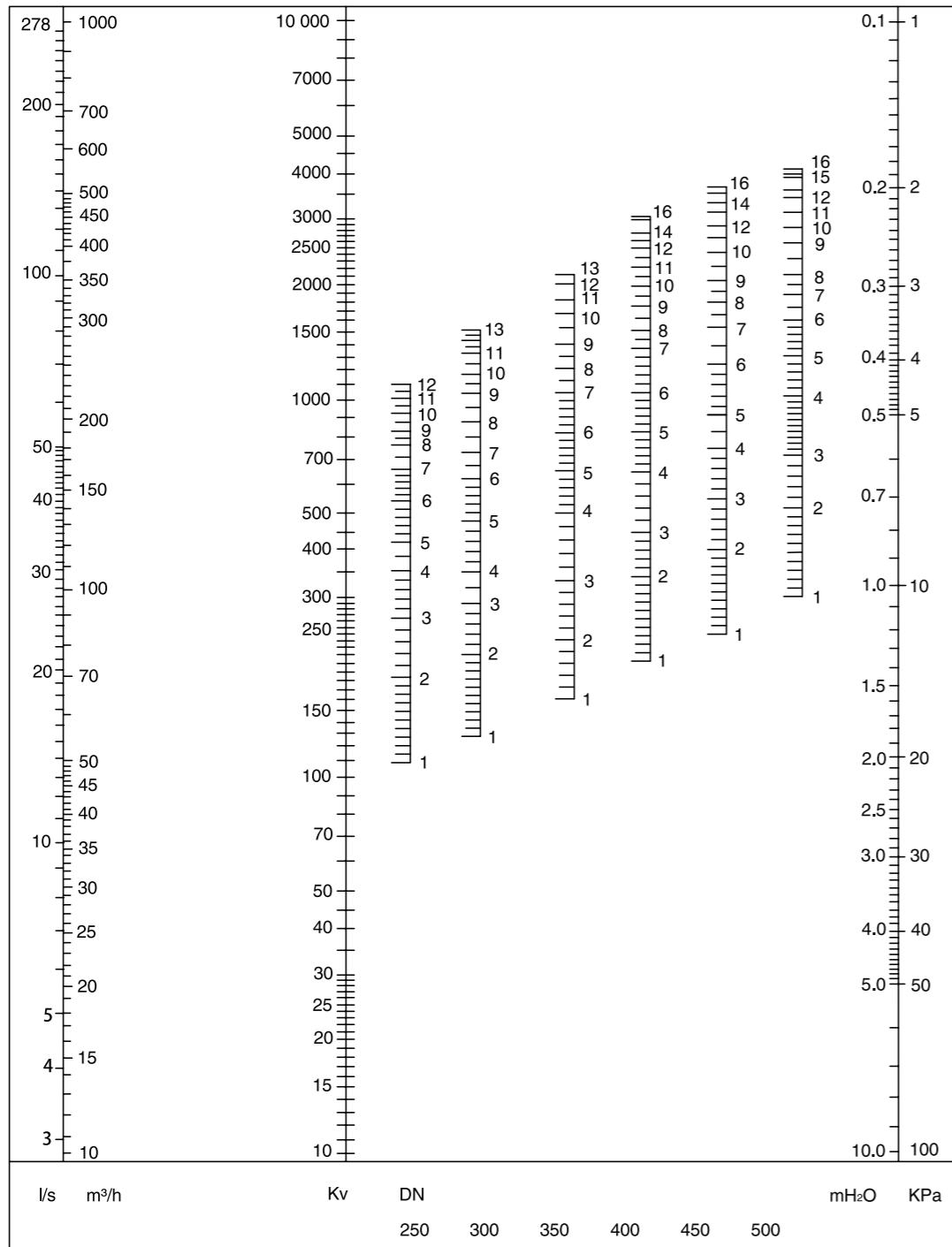

For example:
 Q: An air conditioning system is equipped with a static balancing valve, with a design flow of 60m³/h and a pressure drop of 10 kPa. Now we need to select a suitable size static balancing valve.
 A: As shown in the model selection line diagram, read the position point with q=60m³/h from the left flow scaleline, and read the position point of 10 kPa from the right pressure drop scale line, and connect the two points with the Kv value scale line. When the intersection point kv=187, make the intersection point between the horizontal line and the opening scale line of the balance valve of different diameters. The intersection point of DN 100 is 9 circles, that of DN 125 is 6.8, that of DN 150 is 7, and that of DN200 is 2.9. According to the principle of 75% opening, the balancing valve with diameter of DN 125 should be selected.

iDROSET Series CF

Static Balancing Valve

Size: DN15-DN50

The static balancing valves Series CF, belonging to the iDROSET family are devices designed to calibrate and regulate the water flow in heating and cooling systems and domestic hot or cold water distribution systems. Thanks to its innovative design based in new patented technology, the flow rate can be easily calibrated and read it without the requirement of special tools. These valves can be used as an instant diagnostic tool for monitoring the system performance according to the flow rate.

Features

- Simple and fast adjustment of the flow rate
- No external balancing tool required
- Instant readout
- Shut-off function

Pressure-Temperature

- Nominal Pressure: PN16
- Temperature Range: -10°C~110°C

Flow Rate Sizing Chart

To choose the right size you only need to know the desired flow rate. That value has to be inside the range.

Part n°	DN	Minimum Flow Rate(l/h)	Maximum Flow Rate(l/h)
PAP-S015	1/2"	35	700
PAP-S020	3/4"	35	700
PAP-M025	1"	50	1600
PAP-L032	1 1/4"	250	6000
PAP-L040	1 1/2"	250	6000
PAPXL050	2"	400	10000

The balancing turndown ratio is the largest in the market (up to 25:1) thanks to the new technology present in the device. This means that each diameter has a wide range of flow rate, allowing the use of less different diameters for a wide range of flow rates.

Characteristic Curves

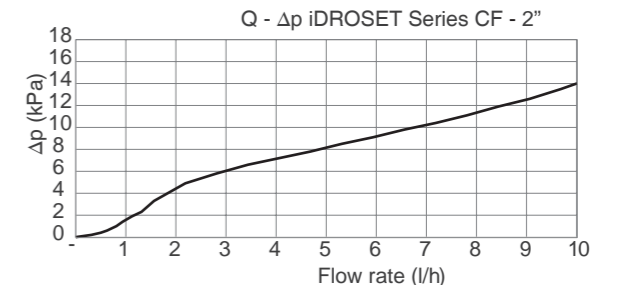
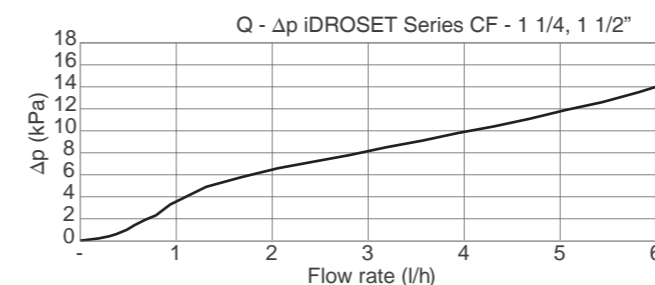
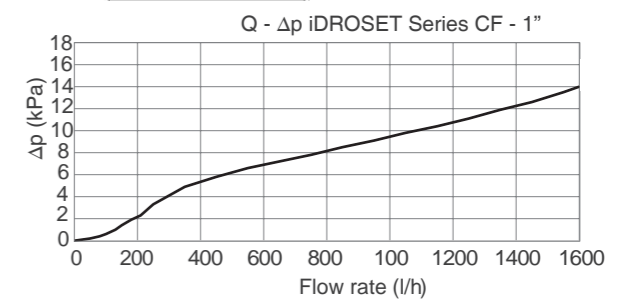
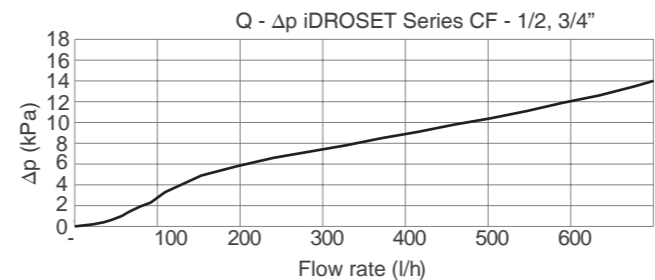

Specification

- Design Standard: New patented technology
- Connection Standard: Threaded to ISO 228
- Pressure Test: Pneumatic 6 bar
- Balancing turndown ratio: 25:1
- Medium: water with glycol up to 50%

Material

NO.	Component	Material
1	Central Body	Polyamide with glass fiber
2	Upper and bottom cap	Brass
3	Hand wheel	Polyamide with glass fiber
4	Spring	Stainless Steel
5	O-ring	EPDM 70 peroxide

Installation Dimension

G	H	L	Kvs
1/2"	83	145	1.7
3/4"	83	152	1.7
1"	83	146	4.4
1 1/4"	132.5	200	14
1 1/2"	132.5	198	14
2"	186	208	25

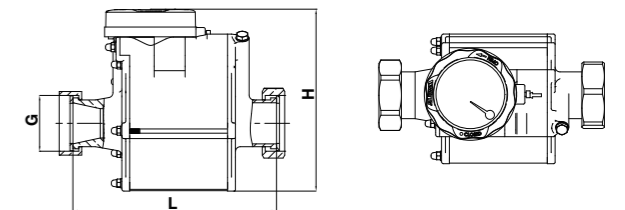



CSM-61-T-EN-202208

Series CSM-61-T

Flow Measurement Valves

Sizes: DN15-DN80

Series CSM-61-T Flow Measurement Valves are designed for application on low or medium flow rate HVAC units recirculation system. Their compact size allows for easy installation and use in crowded piping compartments. The CSM-61-T's ball-type design, extended throttling range, and large indicator plate, make for accurate flow measurement, even in very low flow ranges.

The CSM-61-T's positive memory feature is easy to see, access, and operate, facilitating system balancing and flow measurement. These valves are also bi-directional, so there is no chance of installing the valve in the incorrect flow direction. Series CSM-61-T valves provide positive shutoff, eliminating the need for a separate service valve. These valves are also provided with blowout resistant stems.

Features

- Flow measurement
- Easy to use memory
- Bi-directional flow
- Positive shutoff
- Safe "blowout" resistant
- Integral drain port

Pressure -Temperature

- Working Temperature: 121 C
- Maximum Working Pressure: 300psi (21bar)

Material

Component	Material
Housing/Body	Bronze
Packing Material	Viton® ½" – 2"
Pressure Taps	Neoprene 2½" – 3"
Seats	Brass ¼" SAE 45° Flare
Drain Plug	Carbon/Glass filled PTFE - ½" – 1", 3" Virgin PTFE 1¼" – 2"
	Brass

Installation Dimensions

Model	Size	A(mm)	C(mm)	D(mm)	R(mm)	Weight(Kg)
CSM-61-M1-T	½	60	41	13	45	0.45
CSM-61-M1-T	¾	67	43	15	47	0.59
CSM-61-M1-T	1	80	47	20	52	0.86
CSM-61-M1-T	1¼	94	47	25	56	0.86
CSM-61-M1-T	1½	100	50	27	59	1.04
CSM-61-M1-T	2	114	66	33	66	1.81
CSM-61-M1-T	2½	165	104	55	80	5.90
CSM-61-M1-T	3	173	112	73	92	7.71



CSM-61-T

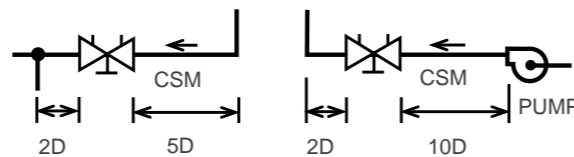

Specification

A flow measurement valve shall be installed on each hot/chilled water unit or as otherwise shown on plans. The valve shall be of the bi-directional, blow-out resistant, tight shutoff, ball design, with position indicator, memory device, checked metering ports with drip caps and integral drain ports opposite the metering ports. The valve shall be a Watts Series CSM-61-T.

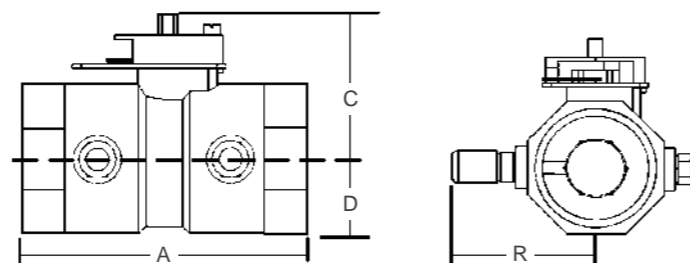

CSM-91-EN-202208

Series CSM-91

Flow Measurement/Balancing Valves

Sizes: DN65-DN250

Series CSM-91 Flow Measurement/Balancing Valves are designed for applications on medium or large flow rate HVAC systems, pump packages, and cooling towers. They feature a multi-turn adjustment range for maximum control. Pressure differential readout ports on both sides of the valve to allow for easier installation and positive shutoff for servicing equipment. In addition, these valves also incorporate a micrometer type handwheel adjustment, visually readable settings and a tamper-proof memory stop.

Features

- Multi-turn adjustment
- Interchangeable metering and drain ports on both sides of valve
- Positive shutoff
- Tamper-proof memory stop
- Micrometer type handwheel adjustment - visually readable from distance
- Field convertible for straight or angle pattern
- Grooved end connections with optional flange adaptors

Material

Component	Material
Body	Ductile Iron ASTM A536 GR65-45-12
Disc	Bronze ASTM B584 C-84400
Seat	2½" – 6" Engineered Resin 8" – 10" EPDM
Stem	Brass ASTM B-16 2½" – 6" Stainless Steel 8" – 10"
O-ring	Buna-N
Memory Lock	Brass ASTM B-16
Meter Ports	NPT Brass body with Schrader Valve
Drain Tappings (2)	¼" Brass plug

Pressure – Temperature

- **Grooved Ends Only**
Maximum Working Pressure: 375psi (26.25 bar)
Maximum Temperature: 230°F (110°C)
- **Flange**
Maximum Working Pressure:
Class 125: 175psi (12 bar)
Maximum Temperature: 230°F (110°C)

Specification

A flow measurement valve shall be installed as shown on plans. Each valve shall have two ¼" NPT brass metering ports with Nordel® check valves and gasketed caps located on both sides of valve seat. Two additional ¼" NPT connections with brass plugs are to be provided on the opposite side of the metering ports for use as drain connections. Drain connections and metering ports are to be interchangeable for measurement flexibility when valves are installed in tight locations. The valve body shall be ductile iron with industrial standard grooved ends. Valve stem and plug disc shall be bronze with ergonomically designed handwheel with multi turn handwheel adjustments. Sizes 2½" and 3" - five turns, 4" – 6" - six turns, and 8" and 10". Flange adaptors shall be supplied to prevent rotation. The valve shall be a Watts Series CSM-91.



Angle Pattern
CSM-91

Straight Pattern

Installation Dimensions

Straight Pattern

Size	Dimensions				Flange Dia. 125#	Spacer	Weight
	A	C	D	F			
in.	mm	mm	mm	mm	mm	mm	kgs
2½	305	245	70	65	178	25	9
3	305	267	62	76	191	25	11
4	356	268	76	87	235	32	19
5	445	332	92	125	254	32	37
6	525	349	113	149	279	51	54
8	716	625	144	200	343	57	141
10	762	673	167	241	406	57	209

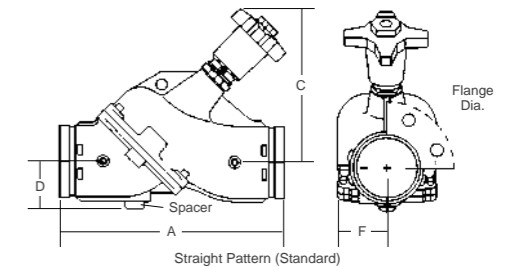

Angle Pattern (Field Convertible*)

SIZE	Dimensions						FLANGE DIA. 125#	Spacer	Weight
	A	C	D	E	F ₁	F ₂			
in.	mm	mm	mm	mm	mm	mm	mm	mm	kgs
2½	257	244	117	187	65	70	178	25	9
3	275	267	98	213	76	62	191	25	11
4	321	268	111	244	87	76	235	32	19
5	397	332	140	305	125	92	254	32	37
6	471	349	168	359	149	113	279	51	54
8	618	625	233	481	200	144	343	57	141
10	683	673	248	516	241	167	406	57	209

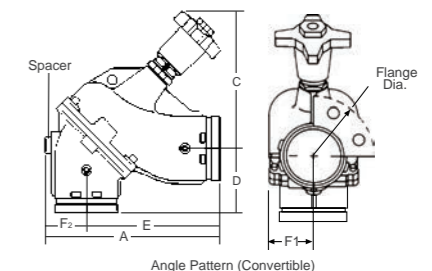

*Note: Series CSM-91 valves are shipped as straight pattern from factory. To convert to angle pattern refer to instruction sheet shipped with valve.



Series W-DPBV-20T

Differential Pressure Balancing Valve

Sizes: DN15-DN50

The Series W-DPBV differential pressure-balancing valve is designed to keep constant differential pressure between supply pipes and return pipes of a bypass, control valve or terminal equipment in air-conditioning or heating system. It avoids hydraulic disturbances resulting from variations in system differential pressure.

Features

- Self-acting differential pressure control, no external power needed
- The on-site setting of differential pressure
- Wide controllable range of differential pressure
- Handwheel equipped with differential pressure indicator
- Able to be shut off by handwheel
- Self-sealing measuring points to protect against leakage
- Equipped with measuring points and air vent
- Equipped with a three-way measuring connector

Working Principle

When the service pressure difference of the system pipe increases, relying on the pressure change of its high and low pressure, the dynamic differential pressure balancing valve's chambers re-balance the forces acting on both sides of the diaphragm, at the same time, it drives the valve stem to move, reduces the valve opening, absorbs the increased utility pressure difference, and ensures the constant pressure difference at the controlled side.

Material

NO.	Component	Material
1	Body	Brass
2	Seal	EPDM
3	Core	Brass
4	Plug	Brass
5	Stem	Brass
6	Spring	Stainless Steel304
7	Membrane	Brass
8	Pressure Pipe Joint	Brass
9	Handwheel	PA

Product Model

Type	Size	ΔP Control(Kpa)	KVs
W-DPBV015S-20T	DN15	5-30	3
W-DPBV020S-20T	DN20	5-30	5.3
W-DPBV025S-20T	DN25	5-30	8.5
W-DPBV032S-20T	DN32	5-30	12
W-DPBV040S-20T	DN40	5-30	19
W-DPBV050S-20T	DN50	5-30	25
W-DPBV015L-20T	DN15	30-70	3
W-DPBV020L-20T	DN20	30-70	5.3
W-DPBV025L-20T	DN25	30-70	8.5
W-DPBV032L-20T	DN32	30-70	12
W-DPBV040L-20T	DN40	30-70	19
W-DPBV050L-20T	DN50	30-70	25

Installation Dimensions

Size	L(mm)	H(mm)	W(mm)
DN15	80	160	112
DN20	85	160	112
DN25	100	165	112
DN32	110	180	112
DN40	120	185	112
DN50	150	200	112



Pressure-Temperature

- Nominal Pressure: PN20
- Working Temperature: -10~120°C

Specification

- Connection Standard: GB/T7306.1, ISO7/1
- Control Accuracy: ±10%
- Maximum Working Differential Pressure: ≤300Kpa
- Working Medium: cold and hot water/ethylene glycol

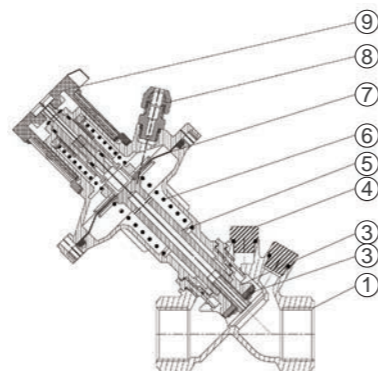

Model Description

W	WATTS	W-	DPBV	025	S-	20	T
DPBV	Dynamic Differential Pressure Balancing Valve						
Size	15-DN15 020-DN20 025-DN25 032-DN32 040-DN40 050-DN50						
ΔP	S:Small Range L:Big Range						
Nominal Pressure	PN20						
Nominal Pressure	Brass						

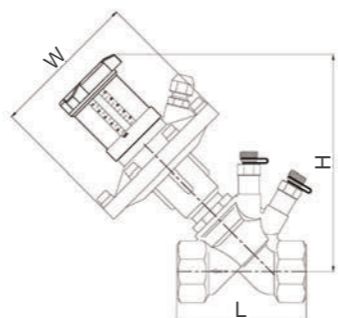

Working Differential Pressure Range

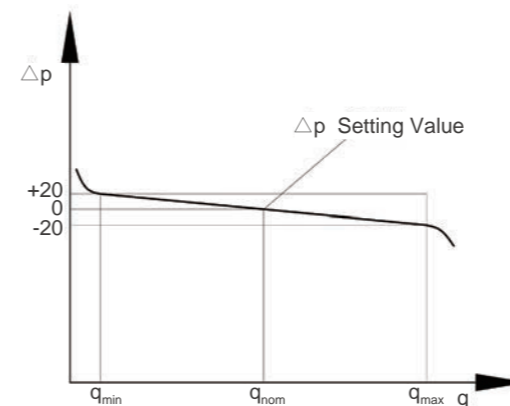

DN	ΔP(kPa)											
	5			10			20			30		
	q _{min}	q _{nom}	q _{max}	q _{min}	q _{nom}	q _{max}	q _{min}	q _{nom}	q _{max}	q _{min}	q _{nom}	q _{max}
15	0.02	0.26	0.51	0.03	0.35	0.73	0.04	0.52	1.0	0.06	0.67	1.25
20	0.03	0.43	0.94	0.04	0.68	1.32	0.06	0.92	1.8	0.08	1.13	2.18
25	0.08	0.75	1.09	0.11	0.98	1.85	0.14	1.35	2.72	0.17	1.98	3.79
32	0.10	1.12	2.30	0.14	1.58	3.02	0.18	2.25	4.26	0.22	3.08	5.7
40	0.12	1.75	3.52	0.25	2.47	4.63	0.38	3.34	6.29	0.61	4.25	7.01
50	0.21	2.33	4.15	0.34	3.01	5.63	0.58	4.21	7.69	0.73	5.07	9.53

DN	ΔP(kPa)											
	40			50			60			70		
	q _{min}	q _{nom}	q _{max}	q _{min}	q _{nom}	q _{max}	q _{min}	q _{nom}	q _{max}	q _{min}	q _{nom}	q _{max}
15	0.07	0.78	1.46	0.08	0.88	1.63	0.09	0.94	1.78	0.1	1.0	1.9
20	0.1	1.32	2.53	0.12	1.51	2.81	0.14	1.62	3.12	0.17	1.78	3.40
25	0.21	2.37	4.42	0.23	2.62	4.98	0.25	2.88	5.45	0.28	3.06	6.37
32	0.3	3.86	7.34	0.38	4.38	8.17	0.46	4.71	8.92	0.52	5.17	9.91
40	0.75	4.97	9.25	0.87	5.51	10.37	0.92	6.12	11.28	1.03	6.53	12.14
50	0.89	6.14	11.15	1.04	6.72	12.48	1.16	7.24	13.69	1.22	7.82	14.85

Installation Instructions

The dynamic differential pressure balancing valve can be used alone or in combination with the static balancing valve. The dynamic differential pressure balancing valve is always installed on the return pipe. When it is used with the static balance valve, the static balancing valve is installed on inlet pipe. Please see as follows.

- ①—DPBV
- ②—STBV
- ③—ECV

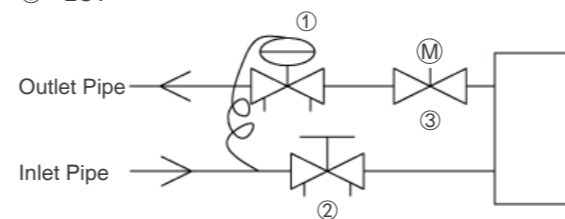



W-DPBV-16/25Q-EN-202206

Series W-DPBV-16/25Q

Differential Pressure Balancing Valve

Size: DN65-DN150

The Series W-DPBV differential pressure-balancing valve is designed to keep constant differential pressure between supply pipes and return pipes of a bypass, control valve or terminal equipment in air-conditioning or heating system. It avoids hydraulic disturbances resulting from variations in system differential pressure.

Features

- Self-acting differential pressure control, no external power needed
- The on-site setting of differential pressure
- Wide controllable range of differential pressure
- Handwheel equipped with differential pressure indicator
- Able to be shut off by handwheel
- Self-sealing measuring points to protect against leakage
- Equipped with measuring points and air vent
- Equipped with three-way measuring connector
- High-pressure guide tube with a small ball valve, eliminate general congestion

Pressure-Temperature

- Maximum Pressure: PN16、PN25
- Working Pressure: 400Kpa
- Temperature Range: -10°C~130°C

Test Pressures

PN16 Hydraulic	PN25 Hydraulic
Shell 24 bar	Shell 37.5 bar

Material

No.	Component	Material
1	Body	Ductile Iron
2	Seat	Stainless Steel (SS304)
3	Core	Stainless Steel (SS304)
4	Measuring Points	CW602N
5	Diaphragm	HNBR
6	Stem	Stainless Steel (SS304)
7	Spring	Stainless Steel (SS304)
8	Sealing	EPDM/FKM
9	Pressure Pipe	T2M
10	Handwheel	PA66

Installation Dimensions

Size	L (mm)	H (mm)	H' (mm)	W (mm)	Weight (kg)
DN65	290	360	453	205	26.5
DN80	310	392	492	225	33.5
DN100	350	470	581	255	47
DN125	400	519	644	293	69.5
DN150	480	592	735	371	102



Specification

- Connection Standard: ISO7005
- Control Deviation: ±8%
- Patent No: ZL 2016 2 0992099.2
- Medium: cold and hot water/ethylene glycol

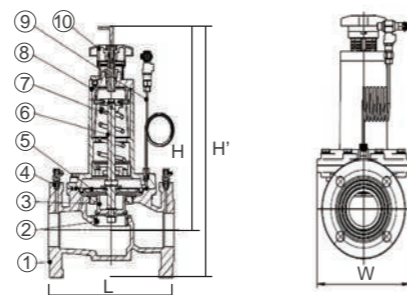

Characteristic Curves

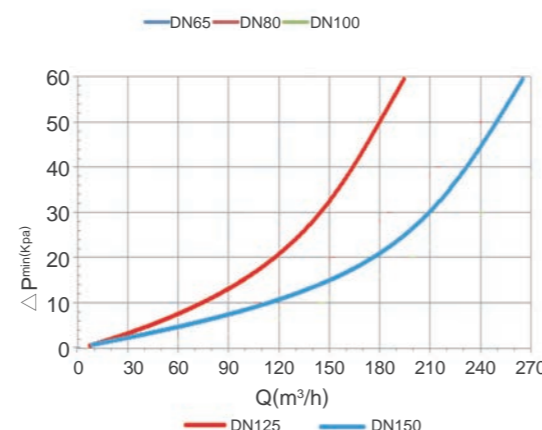
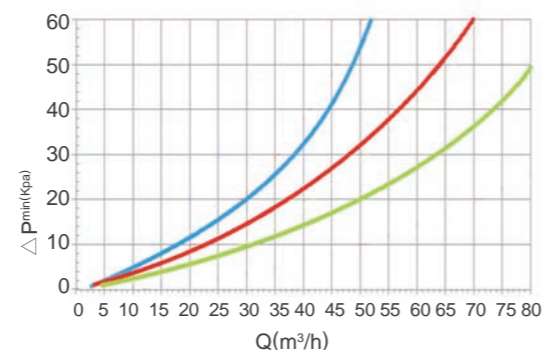

W-DPBV-16/25Q-EN-202206

Models

Type	Size	ΔP Control (Kpa)	KVs	EDP Code
W-DPBV065S-16Q	DN65	20-80	60	61985801
W-DPBV080S-16Q	DN80		80	61985803
W-DPBV100S-16Q	DN100		110	61985805
W-DPBV125S-16Q	DN125		180	61985807
W-DPBV150S-16Q	DN150		250	61985809
W-DPBV065L-16Q	DN65	40-150	60	61985802
W-DPBV080L-16Q	DN80		80	61985804
W-DPBV100L-16Q	DN100		110	61985806
W-DPBV125L-16Q	DN125		180	61985808
W-DPBV150L-16Q	DN150		250	61985810
W-DPBV065S-25Q	DN65	20-80	60	61985981
W-DPBV080S-25Q	DN80		80	61985983
W-DPBV100S-25Q	DN100		110	61985985
W-DPBV125S-25Q	DN125		180	61985987
W-DPBV150S-25Q	DN150		250	61985989
W-DPBV065L-25Q	DN65	40-150	60	61985982
W-DPBV080L-25Q	DN80		80	61985984
W-DPBV100L-25Q	DN100		110	61985986
W-DPBV125L-25Q	DN125		180	61985988
W-DPBV150L-25Q	DN150		250	61985990

ΔP Setting Instruction

Turns	DN65		DN80		DN100		DN125		DN150	
	20-80Kpa	40-150Kpa	20-80Kpa	40-150Kpa	20-80Kpa	40-150Kpa	20-80Kpa	40-150Kpa	20-80Kpa	40-150Kpa
0	20	40	22	44	22	40	21	42	24	41
1	24	46	25	50	26	46	26	48	32	48
2	30	54	30	56	30	54	30	55	37	53
3	35	62	36	62	34	62	34	64	41	59
4	40	70	42	70	38	70	38	67	43	64
5	45	78	48	78	42	77	45	75	48	70
6	50	86	52	87	46	85	48	84	53	78
7	56	96	58	96	50	94	51	93	58	86
8	62	108	65	106	55	105	61	100	59	94
9	68	120	72	118	60	118	64	106	63	102
10	74	134	80	136	66	126	71	116	66	111
11	80	150	88	154	72	138	76	124	70	123
12					79	145	80	135	78	135
13					85	156	85	157	82	146

Series W-DPBV-16/25Q

Differential Pressure Balancing Valve

Size: DN200-DN250

The Series W-DPBV differential pressure-balancing valve is designed to keep constant differential pressure between supply pipes and return pipes of a bypass, control valve or terminal equipment in air-conditioning or heating system. It avoids hydraulic disturbances resulting from variations in system differential pressure.

Features

- Self-acting differential pressure control, no external power needed
- Able to do on-site setting of differential pressure
- Wide controllable range of differential pressure
- Handwheel equipped with differential pressure indicator
- Self-sealing measuring points to protect against leakage
- Equipped with measuring points and air vent
- Equipped with a three-way measuring connector

Working Principle

When the service pressure difference of the system pipe increases, relying on the pressure change of its high and low pressure, the dynamic differential pressure balancing valve's chambers re-balance the forces acting on both sides of the diaphragm, at the same time, it drives the valve stem to move, reduces the valve opening, absorbs the increased utility pressure difference, and ensures the constant pressure difference at the controlled side.

Temperature - Pressure

- Nominal Pressure: -10~80°C
- Nominal Pressure: PN16、PN25

Material

No.	Component	Material
1	Upper Bonnet	Ductile Iron
2	Membrane	EPDM
3	Stem	Stainless Steel
4	Core	Stainless Steel
5	Body	Ductile Iron
6	Lower Bonnet	Ductile Iron
7	Handwheel	Nylon
8	Spring	Stainless Steel
9	Adjustable Stem	Stainless Steel
10	Seal	NBR
11	Measuring Mouth	Brass

Product Model

Type	Size	ΔP kPa	Kvs	EDP
W-DPBV200L-16Q	DN200	40-180	320	61180020
W-DPBV250L-16Q	DN250	40-180	400	61180021
W-DPBV200L-25Q	DN200	40-180	320	61180022
W-DPBV250L-25Q	DN250	40-180	400	61180023



Specification

- Connection Type: Flange
- Connection Standard: EN1092-2
- Control Accuracy: ±8%
- Maximum Working Differential Pressure: ≤ 400KPa
- Working Medium: Cold And Hot Water/ethylene Glycol

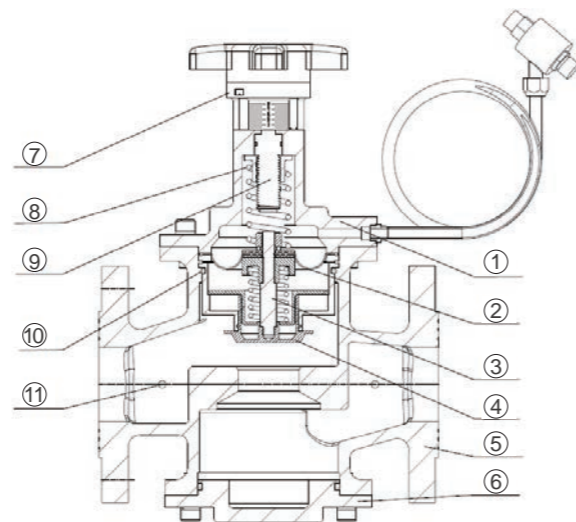

Model Description

W	WATTS
DPBV	Differential Pressure Balancing Valve
Size	200-DN200 250-DN250
ΔP	L: Pressure Range 40-180kPa
Nominal Pressure	PN16 PN25
Material	Ductile Iron

Installation Dimensions

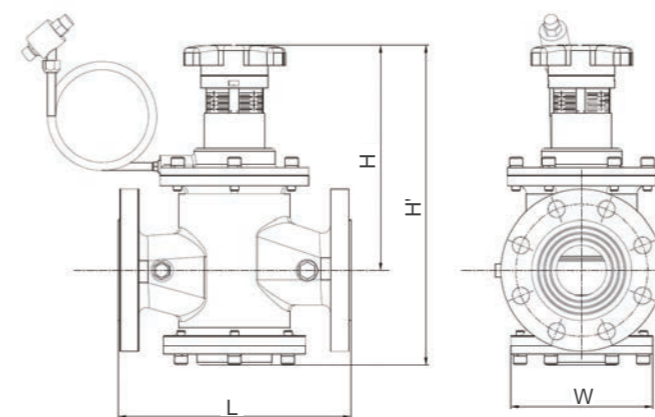

Size	L (mm)	H (mm)	H' (mm)	W (mm)	Weight (Kg)
DN200	600	440	650	390	195
DN250	730	480	730	440	285

Installation Instructions

The dynamic differential pressure balancing valve can be used alone or in combination with the static balancing valve. The dynamic differential pressure balancing valve is always installed on the return pipe. When it is used with the static balance valve, the static balancing valve is installed on inlet pipe. Please see as follows.

- ①—DPBV
- ②—STBV
- ③—ECV

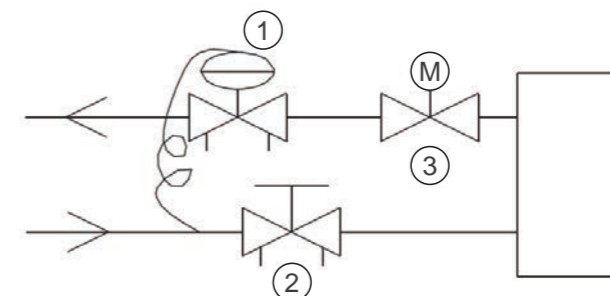

Pressure Setting

Turns	DN200 40-180Kpa	DN250 40-180Kpa
0	40	40
1	50	50
2	60	60
3	70	70
4	80	80
5	90	90
6	100	100
7	110	110
8	120	120
9	130	130
10	140	140
11	150	150
12	160	160
13	170	170
14	180	180



W-PICVXXX-25T/25Q-EN-202212

Series W-PICVXXX-25T/25Q

Pressure Independent Control Valve

Size: DN15-DN50

Series W-PICVXXX-25T/25Q pressure independent control valve is designed for terminal equipment in AHU, PAU or MAU system to regulate the flow through the valve as well as to keep the constant differential pressure at both ends of the valve. It avoids the flow fluctuation caused by the opening or closing of other equipment in the system so as to keep the system stable, efficient and energy-saving.

Features

- Constant differential pressure between the two ends of the control Valve
- Equal percentage flow characteristics with actuator
- Preset maximum flow rate to facilitate on-site debugging
- Designed with front and rear differential pressure measuring nozzles
- Dust-proof O-ring design & O-ring on disc for zero leakage
- BSRIA Tested

Pressure - Temperature

- Temperature Range: -10~120 C
- Nominal Pressure: PN25
- Working Differential pressure: 30KPa-600KPa

Material

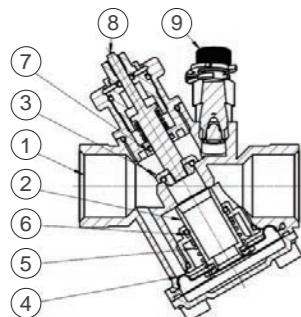

DN15-DN32

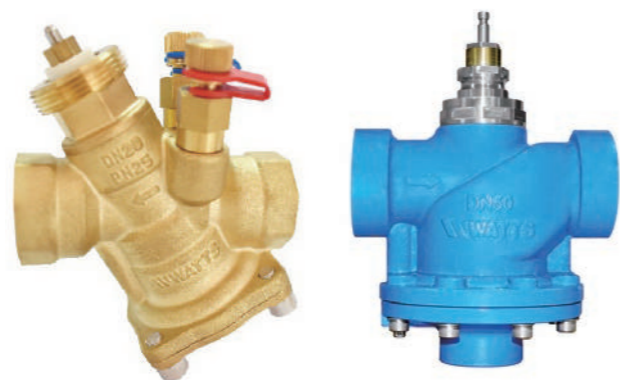

DN15-DN32

DN40-DN50

Specification

- Connection Mode: Threaded connection
- Thread Standard: GB/T 7306.1 ISO 7-1
- Protection Level of Actuator: IP54
- Working Medium: Air conditioning hot and cold water, ethylene glycol solution

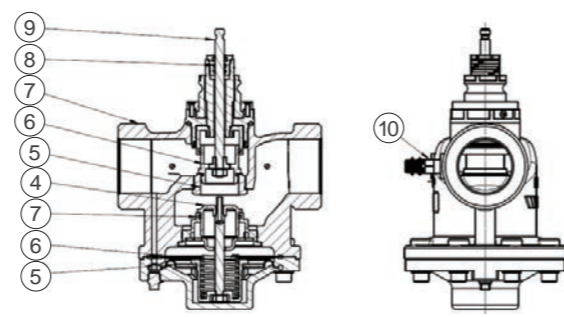

DN40-DN50

No.	Component	Material
1	Valve Body	DZR Brass (DN15-DN25) Bronze (DN32)
2	Differential Pressure valve spool	Stainless Steel
3	Control Valve Spool	Brass
4	Diaphragm	HNBR
5	Spring	Stainless Steel
6	Seal Ring	HNBR
7	Valve Stem Seal	HNBR
8	Valve Stem	Stainless Steel
9	Measuring Nozzle	DZR Brass

No.	Component	Material
1	Valve Body	Ductile Iron
2	Valve Seat	Stainless Steel
3	Differential Pressure valve spool	Stainless Steel
4	Control Valve Spool	Stainless Steel
5	Diaphragm	HNBR
6	Spring	Stainless Steel
7	Seal Ring	HNBR
8	Valve Stem Seal	HNBR
9	Valve Stem	Stainless Steel
10	Measuring Nozzle	DZR Brass



W-PICVXXX-25T/25Q-EN-202212

Installation Dimensions

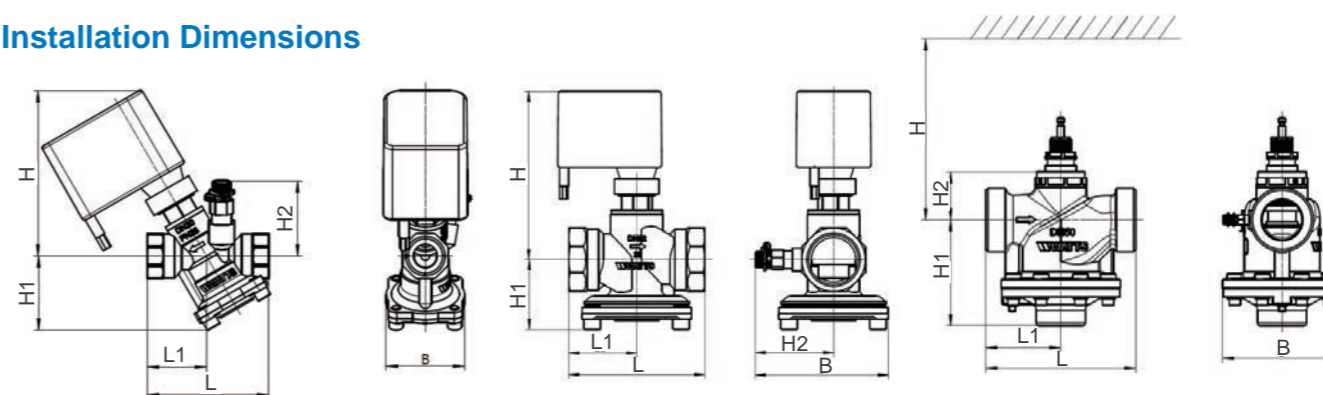

DN	Thread	L	L1	B	H	H1	H2	Weight of valve body KG
15	Rp 1/2	82	39.9	55	117	53	53	0.67
20	Rp 3/4	85	41.4	55	117	53	53	0.69
25	Rp 1	96	44.6	60	116	63	58	0.95
32	Rp 1 1/4	107	53.5	105	132	55	62	1.47
40	Rp 1 1/2	214	107	170	403	151	68	11.9
50	Rp 2	214	107	170	403	151	68	12.1

DN15-DN32 actuator leaves ≥ 50mm operation space.

Flow Setting

Through the hexagonal at the top of the valve, 30% to 100% of opening can be preset, with the factory default of 100%. This function can not only meet the needs of special users, but also improve the control accuracy.

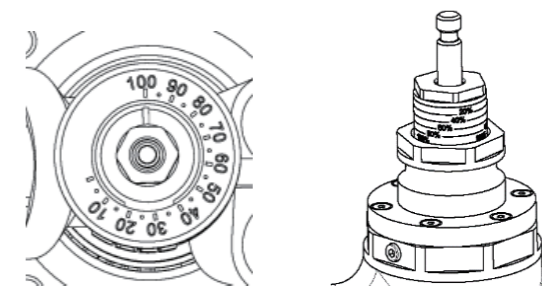

Opening regulation

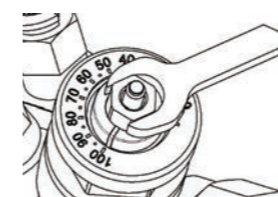

DN15-DN32



DN40-DN50 Loosen the lock nut before preset, and tighten it

Flow Rate

Table of Flow Rate with Preset Opening (m³/h)

Opening Caliber	10%	20%	30%	40%	50%	60%	70%	80%	90%	100%
DN15	0.11	0.21	0.30	0.39	0.47	0.56	0.66	0.76	0.90	1.05
DN20	0.11	0.21	0.30	0.39	0.47	0.56	0.66	0.76	0.90	1.05
DN25	0.1	0.2	0.3	0.6	0.9	1.2	1.5	1.7	2.1	2.5
DN32	0.3	0.5	0.9	1.3	1.7	2.1	2.5	2.8	3.1	3.3
DN40	0.7	2	2.8	3	3.7	4.3	5.9	8.2	10.7	13
DN50	0.7	2	2.8	3	3.7	4.3	5.9	8.2	10.7	13



W-PICVXXX-25T/25Q-EN-202212

Product Type

Model	Size	EDP	Max Flow Rate(M ³ /h)	Valve Stem Travel(Mm)	Supporting Actuator
W-PICV015-25T	DN15	61984715	1.05	3.2	W-AR2M-16
W-PICV020-25T	DN20	61984716	1.05	3.2	W-AR2M-16
W-PICV025-25T	DN25	61984717	2.5	5.5	W-AR2M-25
W-PICV032-25T	DN32	61984718	3.3	5.5	W-AR2M-25
W-PICV040-25Q	DN40	61984719	13	15	W-A11A1X
W-PICV050-25Q	DN50	61984720	13	15	W-A11A1X

Actuator Type

Model	EDP	Output Shut-Off Force (N)	Operating Voltage	Control Model	Running Speed(s/mm)
W-AR2M-16	61230019	> 160	24VAC	0(2)-10V	5
W-AR2M-25	61230020	> 250	24VAC	0(4)-20mA	5
W-A11A1X	616P2241	500-700	24VAC	0(4)-20mA	3.85

Installation Instruction

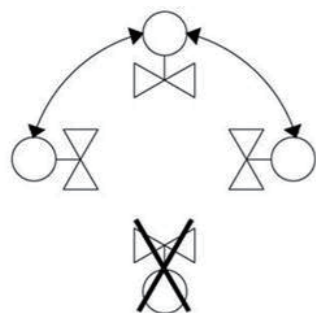

Prohibit downward installation of actuators

Model Description

W	WATTS	W-	PICV	020	-25	T
PICV Pressure Independent Control Valve						
Size						
015-050: DN15-DN50						
Pressure						
25: PN25						
Body Material						
T: Copper Q: Ductile Iron						



W-AR-EN-202212

Series W-AR

Electric Actuator

Series W-AR actuator is widely used in auto-control system to regulate the opening rate of electronic valves. Along with Series W-PICV valve body, the actuator is able to control the system's temperature, pressure and flow through receiving different kinds of signals.

Features

- Easy to debug on site, no need to remove the shell
- Electronic presetting facilitates on-site commissioning
- Manual operation facilitates on-site trouble-shooting
- Precise positioning achieved by self-calibration function

Working Principle

Modulation Type W-AR2M

The modulation type electric actuator can realize equal percentage flow control. By inputting 0 (2) - 10VDC and 0 (4) - 20mA control signals, the feedback output signal of valve position can be observed, and the automatic regulation and control of pipeline fluid medium can be realized, which makes the application of control valve more flexible. After the modulation type electric actuator is powered on, by pressing the SW1 learning / reset button on the shell, the actuator will firstly go down to find the valve closing position, and then reverse the upward direction to return to the reference position and stop. After the self-adaptation is completed, it will automatically enter the operation state. MCU (chip) will automatically save the parameters obtained during learning, and it will not be lost even after power failure. At this time, the driver power indicator on long time light indicates that the self-adaptive is over, and the coordination and adjustment of valve body and driver are completed. Currently, the running direction of the driver is controlled by the control signal. When the driver is powered on, press the SW1 learning / reset button on the shell to enter the adaptive state if it needs to be adaptive.

On-off Type W-AR1S

The W-AR1S motorized actuator accepts two-wire and one-control on/off type control. When the power is switched on, the actuator drives the screw downwards one-way to close the valve. When the external power is cut off, auto reset is triggered electronically to drive the screw upwards to keep the valve open.



Model Description

W	WATTS	A	R	1	S-	16
A Electric Actuator						
R Multi-turn						
Power Supply:						
1=110-240VAC						
2=24VAC/DC						
Control Mode:						
S =ON/OFF Type M=Modulation Type						
Output Force:						
16=160N 25=250N						

Material

Component	Material
Upper Shell	Flame-Retardant ABS Engineering Plastics
Lower Shell	Glass Fiber Flame-Retardant Nylon PA66+30%
Center Crew and gear	10% Glass Fiber Reinforced POM
Connecting Nut	Brass HPb59-1

Installation Dimensions (mm)

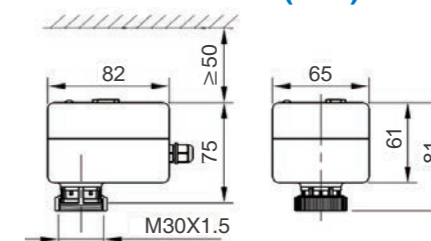

Upstream installation dimension of 160N actuator=13.6mm
Upstream installation dimension of 250N actuator=15.8mm

Specifications

Model No.	W-AR1S-16	W-AR1S-25	W-AR2M-16	W-AR2M-25
Thrust Output	> 160N	> 250N	> 160N	> 250
Power Supply	110-240VAC 50/60Hz		24VAC/DC±10%	
Control Signal	On/off type (two-wire, one control)		0(2)-10V DC(input resistance 200KΩ) Or 0(4)-20mA DC(input resistance 500Ω)	
Feedback Signal	—		0-10V DC (1mA)	
Connecting Wire Spec.	Two-core Length 200mm (2X0.5mm ²)		Four-core Length 400mm (4X0.3mm ²)	
Power Consumption	< 2W			
Operating Time	≈ 5s/mm			
Max. Stroke	6.5mm			
Factory Preset	The actuator drives the screw downwards to close the valve when the power is on and drives the screw upwards to open the valve when power is off.		Switch JP1 setting: 0-10 V DC control, RA status: the actuator drives the screw upwards to close the valve by 0V control signal and drives the screw upwards to open the valve by 10V control signal.	
Protection Class	IP54			
Temperature Limits	Operation: 2 ~ +55°C Storage: - 20 ~ +65°C			
Max. RH	< 90% and no condensation			



Wiring for On/Off Type

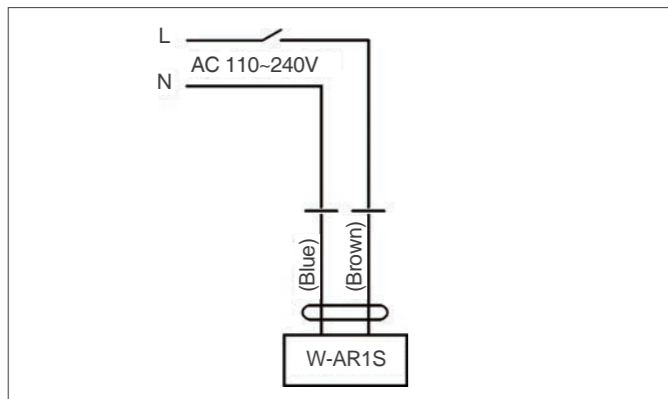

Wiring for Modulation Type

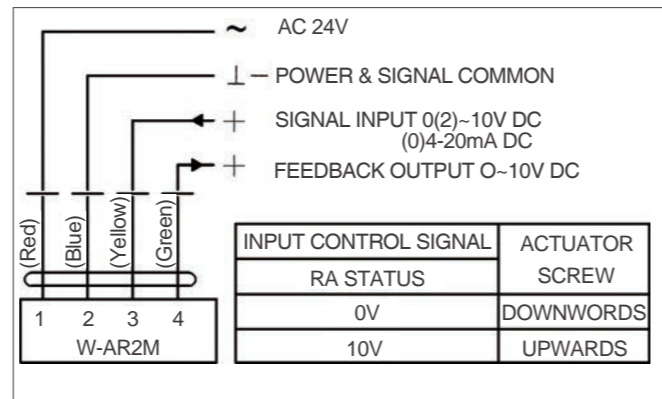

Installation Instruction

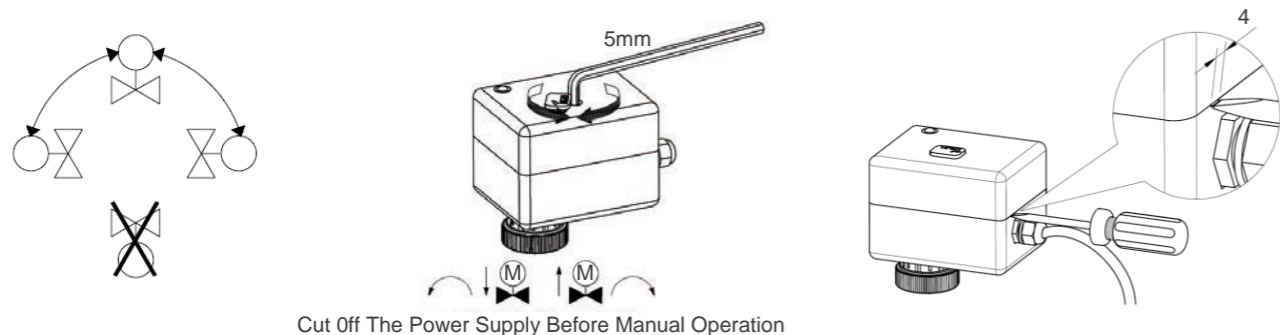

Cut Off The Power Supply Before Manual Operation

Notes

- The actuator's screw is preset upwards to the top (position of fully open valve) in the factory, allowing for direct connection with the valve. If the actuator is electrically tested before installing (for example in the 0V status) and the screw is set downwards to the bottom; the screw must be set to the top by powering on or manual operation before installation, in order to connect to the valve.
 - Leave enough space over the actuator for easy disassembly and maintenance.
 - The actuator must be protected against water leakage and damage to the internal components.
 - Manual operation is forbidden when the actuator is powered on.
- Self-stroking for W-AR2M modulation type actuator: Do not need to disassemble the housing. Press the Learn/Reset Button SW1 on the shell after the actuator is power on. The actuator will drive the screw downwards and check the position for closing the valve, then upwards and stop after it returning to the preset position. The self-stroking is completed and the actuation will automatically enter the operation status. The MCU (chip) will automatically save the parameters during the self-stroking and the parameters will not be lost after powering off.
- Control signal and status shift of W-AR2M modulation type actuator: Disassemble the housing by straight screwdriver. Set the JP1 switch (refer to the table above) correctly according to the required functions after powering on. Then press the SW1 Learn/Reset button. The indicator light flashes in the Learn status, the actuator will drive the screw downwards and check the position for closing the valve, then upwards and stop after returning to the preset position. The indicator light stops flashing and is on after self-stroking is completed. The actuation will automatically enter the operation status.

JP1 SWITCH SETTING					PCB	
Mode	Ctrl Signal	0-10V DC	2-10V DC	0-20mA DC	4-20mA DC	
RA	0% =					STUDY/RESET BUTTON
DA	0% =					INDICATOR LIGHT

SW1: STUDY/RESET BUTTON

LED1: INDICATOR LIGHT

JP1: SWITCH 1=V/mA CONTROL SIGNAL VOLTAGE(OFF) CURRENT(ON)

SW2: SWITCH 2= DA/RA STATUS DA(OFF)/RA(ON)

SW3: SWITCH 3= CONTROL SIGNAL START SETTING 0V/0mA(OFF); 2V/4mA(ON)



Series W-PICV-16/25Q

Pressure Independent Control Valve

Size: DN65-DN150

The Series W-PICV pressure independent control valve is designed for terminal equipment in AHU, PAU or MAU system to regulate the flow through the valve as well as to keep a constant differential pressure at both ends of the valve. It avoids flow fluctuation caused by the opening or closing of other equipment in the system so as to keep the system stable, efficient and energy-saving.

Features

- Equal percentage flow characteristic
- Constant differential pressure is achieved
- Self-balancing valve core realizes easy shutoff
- V-ring sealing and self-compensating spring result in higher abrasion resistance and longer service life
- Electronic preset of maximum flow facilitates on-site commissioning
- Fault auto-detection and alarm function
- Overload protection for power supply, Stroke auto-detection
- Manual lever for convenient on-siting commissioning and troubleshooting
- Spring is cut off from the water, longer service life

Pressure-Temperature

- Maximum Pressure: PN16、PN25
- Working ΔP : 35-400Kpa
- Temperature Range: -10° C~130° C

Test Pressures

PN16 Hydraulic	PN25 Hydraulic
Shell 24 bar	Shell 37.5 bar

Material

No.	Component	Material
1	Body	Ductile Iron
2	Seat	Stainless Steel
3	Differential pressure Valve Core	Stainless Steel
4	Control Core	Stainless Steel
5	Membrane	HNBR
6	Spring	Stainless Steel
7	Sealing	HNBR
8	Membrane	HNBR&PTFE
9	Stem	Stainless Steel
10	Measuring Points	Brass

Installation Dimensions

DN	PN16			PN25			d	f	C	L	L1	B	H	H1	H2	Body Weight (kg)
	D	K	nxL	D	K	nxL										
65	185	145	4x19	185	145	8x19	118	3	19	290	145	204	415	212	80	25
80	200	160	8x19	200	160	8x19	132	3	19	310	155	224	419	215	84	29
100	220	180	8x19	235	180	8x23	156	3	19	350	175	255	672	231	127	41
125	250	210	8x19	270	220	8x28	184	3	19	400	200	293	673	290	128	60
150	285	240	8x23	300	250	8x28	211	3	19	480	240	371	690	320	145	86



Specification

- Connection Standard: ISO7005
- Flow Deviation: $\pm 5\%$
- Protection Grade: IP54
- Control Characteristic: equal percentage
- Medium: water/ethylene glycol

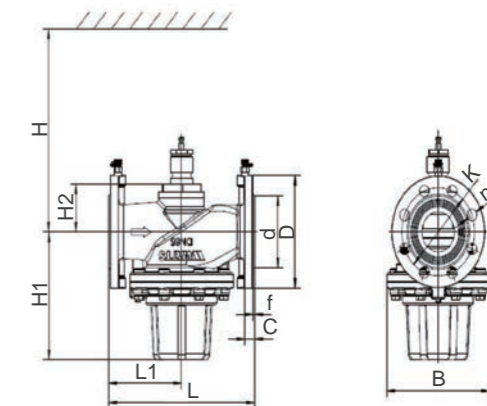
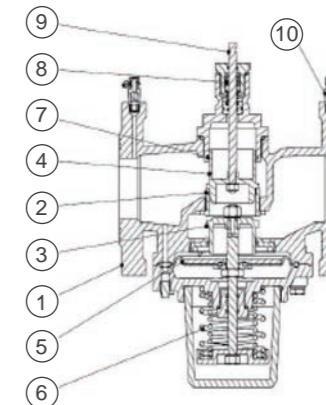



W-PICV-16/25Q-EN-202212

Series W-PICV-16/25Q

Pressure Independent Control Valve

Size: DN200-DN250

The Series W-PICV pressure independent control valve is designed for terminal equipment in AHU, PAU or MAU system to regulate the flow through the valve as well as to keep a constant differential pressure at both ends of the valve. It avoids flow fluctuation caused by the opening or closing of other equipment in the system to keep the system stable, efficient and energy-saving.

Features

- Equal percentage flow characteristic
- Constant differential pressure is achieved
- Self-balancing valve core realizes easy to shut off
- V-ring sealing and self-compensating spring result in higher abrasion resistance and longer service life
- Electronic preset of maximum flow facilitates on-site commissioning
- Fault auto-detection and alarm function
- Overload protection for power supply, stroke auto-detection
- Manual lever for convenient on-siting commissioning and troubleshooting

Pressure-Temperature

- Maximum Pressure: PN16、PN25
- Working ΔP : 35~400Kpa
- Temperature Range: -10°C~120°C

Test Pressures

PN16 Hydraulic	PN25 Hydraulic
Shell 24 bar	Shell 37.5 bar

Material

No.	Component	Material
1	Body	Ductile Iron
2	Valve Core	Stainless Steel
3	Stem	Stainless Steel
4	Spring	Stainless Steel
5	Spring	PTFE
6	Membrane	EPDM

Installation Dimensions

Size	L (mm)	H (mm)	H' (mm)	W (mm)	Weight (kg)
DN200	500	502	801	400	140
DN250	600	564	863	445	207

Models

Body

Type	Size	EDP Code	Rated Flow (m³/h)	Stroke (mm)	Actuator Force (N)
W-PICV200-16Q	DN200	61816047	208	40	W-A11D1X
W-PICV250-16Q	DN250	61816041	240		
W-PICV200-25Q	DN200	616P2211	208		
W-PICV250-25Q	DN250	616P2212	240		

Actuator Type

Type	EDP Code	Rated Output Force (N)	Actual Output Force (N)	Working Voltage	Control Signal	Actuating Time (s/mm)
W-A11D1X	616P2244	3000	3000	24VAC	0(2)~10V, 0(4)~20mA	3.2



Specification

- Connection Standard: ISO7005
- Flow Deviation: $\pm 5\%$
- Protection Grade: IP54
- Control Characteristic: equal percentage
- Medium: water/ethylene glycol/propylene glycol

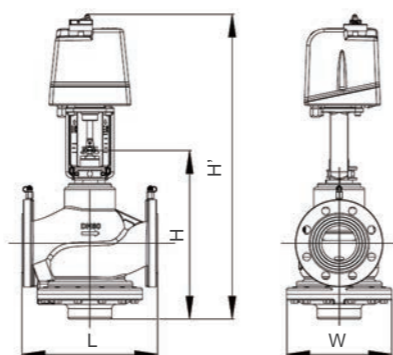
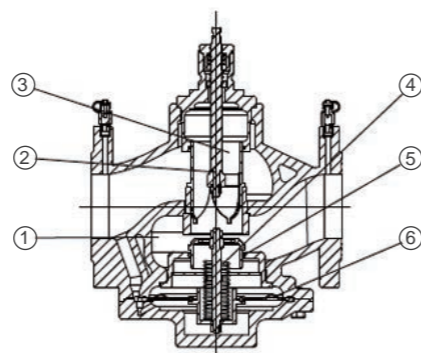

AR12-EN-202212

Series W-AR12

Electrical Control Valve Actuator

The W-AR1S motorized actuator accepts two-wire and one-control on/off type control. When the power is switched on, the actuator drives the screw upwards one-way to open the valve. When the external power is cut off, auto reset is triggered electronically to drive the screw downwards to keep the valve close.

The W-AR2M motorized actuator accepts modulating control with the built-in PCB accommodating the stroke parameters. After connecting with the valve body, the actuator stroke can be seamlessly coordinated with the valve body stroke through e-learning. It can receive direct current control signals of 0~10V DC and provide feedback position signals of 0~10V DC.

Since the actuator and the valve are connected by a screw nut, simple, flexible and convenient on-site assembly can be realized by connecting the actuator to the valve after the valve is installed. Equipped with a valve, it can regulate the flow of cold or hot water and be widely used in the fluid control of central air conditioning, heating, water treatment, industrial processing industry and other systems.



Coding Rules

W	A	R	2	M	12	NC
W WATTS	A Electric Actuator	R Multi-turn				
Power Supply:						
1 = 110~240VAC						
2 = 24VAC/DC						
Control Mode:						
S = ON/OFF Type M=Modulation Type						
Output Force:						
12 = 120N 16 = 160N 25 = 250N						
Fail Safe						
NC = Normal Close NO = Normal Open						

Operation Direction

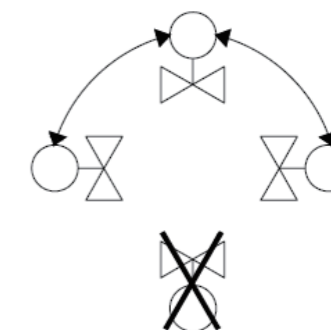

Technical Specification

Model No.	W-AR1S-12	W-AR2M-12
Action	ON/OFF	Modulation
Thrust Output	120N	120N
Power Supply	110~240VAC 50/60Hz	24VAC/DC $\pm 10\%$
Control Signal	On/off type (two-wire, one control)	0~10V DC (input resistance 200K Ω)
Feedback Signal	—	0~10V DC (1mA)
Connecting Wire Spec.	200mm long two-core, (2X0.5mm ²)	400mm long four-core (4X0.5mm ²)
Power Consumption	5W	2W
Operating Time	$\approx 5s/mm$	
Max. Stroke	5 mm	
Factory Preset	The actuator drives the screw upwards to open the valve when the power is on and drives the screw downwards to close the valve when power is off.	RA status: the actuator drives the screw upwards to close the valve by 0V control signal and drives the screw upwards to open the valve by 10V control signal.
Protection Class	IP54	
Temperature Limits	Operation: 2 ~ +55°C Storage: -20 ~ +65°C	
Max. RH	< 90% and no condensation	



Wiring drawings for Actuators

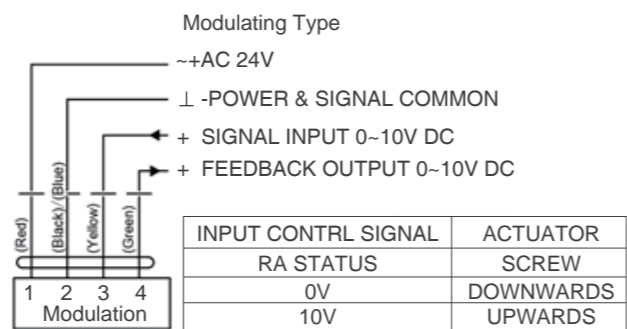
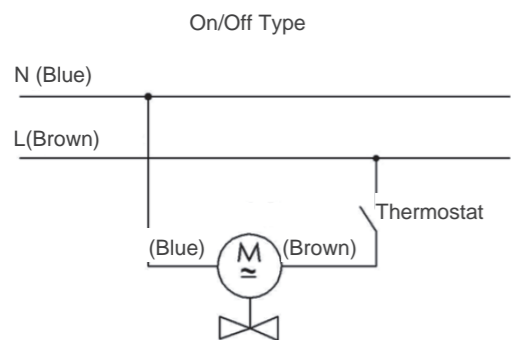

Installation Dimensions

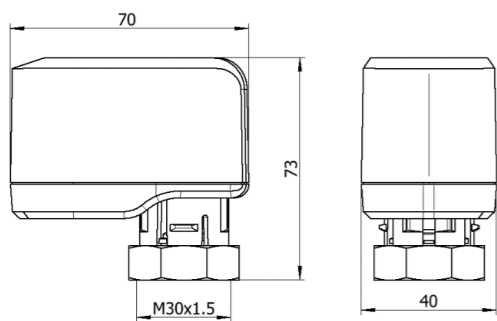

Notes:

- 1.The actuator' s screw is preset upwards to the top (position of fully open valve) in the factory, allowing for direct connection with the valve. If the actuator is electrically tested before installing (for example in the 0V status) and the screw is set downwards to the bottom; the screw must be set to the top by powering on (in the 10V status) before installation to connect to the valve.
- 2.Leave enough space over the actuator for easy disassembly and maintenance.
- 3.The actuator must be protected against water leakage and damage to the internal components.
- 4.Install the actuator by fully tightening the ring-nut on the valve body thread by hand (no multigrip plier tool).



Series W-A11

Electrical Control Valve Actuator

Series W-A11 actuator is widely used in the auto-control system to regulate the opening rate of electronic valves. Along with Watts Series W-912, Series W-942 or Series W-943 valve body, the actuator is able to control the system' s temperature, pressure, and flow through receiving different kinds of signals.

Features

- With valve position indicator
- Electronic presetting facilitates on-site commissioning
- Manual operation facilitates on-site trouble-shooting
- Automatic fault detection and alarm functions
- Overload protection function for the power supply
- It automatically runs self-calibration function when first starts up, helpful for precise positioning

Material

Component	Support	Shell	
		500/1000N	1800/3000/5000/16000N
Material	Die Casting Aluminum	PC	Die Casting Aluminum



Specification

- Connection Standard: ISO7/1
- Control Deviation: ±25%
- Medium: cold and hot water/ ethylene glycol

Installation Dimensions

Size	L (mm)	H (mm)	W (mm)	Weight (kg)
500N	122	238	120	1.8
1000N	122	238	120	1.8
1800N	187	376	174	5.5
3000N	187	376	174	5.5
5000N	187	376	174	5.5
16000N	280	726	330	50

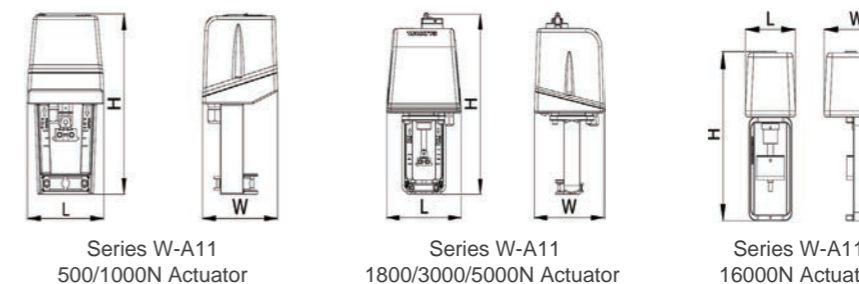

Model

No.	Type	Name
1	W-A11A1X	500N Intelligent Proportional Control Actuator (24VAC)
2	W-A11A2X	500N Intelligent Proportional Control Actuator (220VAC)
3	W-A11A1F	500N Floating Point Control Actuator (24VAC)
4	W-A11A2F	500N Floating Point Control Actuator (220VAC)
5	W-A11B1X	1000N Intelligent Proportional Control Actuator (24VAC)
6	W-A11B2X	1000N Intelligent Proportional Control Actuator (220VAC)
7	W-A11B1F	1000N Floating Point Control Actuator (24VAC)
8	W-A11B2F	1000N Floating Point Control Actuator (220VAC)
9	W-A11C1X	1800N Intelligent Proportional Control Actuator (24VAC)
10	W-A11C2X	1800N Intelligent Proportional Control Actuator (220VAC)
11	W-A11C1F	1800N Floating Point Control Actuator (24VAC)
12	W-A11C2F	1800N Floating Point Control Actuator (220VAC)
13	W-A11D1X	3000N Intelligent Proportional Control Actuator (24VAC)
14	W-A11D2X	3000N Intelligent Proportional Control Actuator (220VAC)
15	W-A11D1F	3000N Floating Point Control Actuator (24VAC)
16	W-A11D2F	3000N Floating Point Control Actuator (220VAC)
17	W-A11E1X	5000N Intelligent Proportional Control Actuator (24VAC)
18	W-A11E2X	5000N Intelligent Proportional Control Actuator (220VAC)
19	W-A11E1F	5000N Floating Point Control Actuator (24VAC)
20	W-A11E2F	5000N Floating Point Control Actuator (220VAC)
21	W-A11F2X	16000N Intelligent Proportional Control Actuator (220VAC)

Coding Rules

W	WATTS
A	Actuator
11	Linear Motion
Output Force	
A=500N	B=1000N
C=1800N	D=3000N
E=5000N	F=16000N
Working Voltage	
1: 24 VAC	2: 220 VAC
Control Type	
X:	Intelligent Proportional Control
F:	Floating Point Control

Technical Specification

Intelligent Proportional Control Actuator

Type	W-A11A1(2)X	W-A11B1(2)X	W-A11C1(2)X	W-A11D1(2)X	W-A11E1(2)X	W-A11F2X
Power Voltage	1:24VAC 2:220VAC	1:24VAC 2:220VAC	1:24VAC 2:220VAC	1:24VAC 2:220VAC	1:24VAC 2:220VAC	2:220VAC
Power Frequency (Hz)	50±1%	50±1%	50±1%	50±1%	50±1%	50±1%
Energy Consumption	7.5VA	7.5VA	12VA	12VA	12VA	100VA
Rated Actuator Force (N)	500	1000	1800	3000	5000	16000
Actual Actuator Force (N)	500-700	1000-1200	1800-2000	3000-3500	4500-5500	16000-16500
Action Time (s/mm)	3.85	3.85	3.20	3.20	2.70	1.00
Stroke (mm)	22	22	42	42	42	110
IP Grade	IP54	IP54	IP54	IP54	IP54	IP54
Input Signal	0(2)-10VDC, 0(4)-20mA	0(2)-10VDC, 0(4)-20mA	0(2)-10VDC, 0(4)-20mA	0(2)-10VDC, 0(4)-20mA	0(2)-10VDC, 0(4)-20mA	0(2)-10VDC, 0(4)-20mA
Output Signal	0(2)-10VDC, 0(4)-20mA	0(2)-10VDC, 0(4)-20mA	0(2)-10VDC, 0(4)-20mA	0(2)-10VDC, 0(4)-20mA	0(2)-10VDC, 0(4)-20mA	0(2)-10VDC, 0(4)-20mA
Wiring Diagram	24VAC: Fig.1 220VAC: Fig.2	24VAC: Fig.1 220VAC: Fig.2	24VAC: Fig.1 220VAC: Fig.2	24VAC: Fig.1 220VAC: Fig.2	24VAC: Fig.1 220VAC: Fig.2	Fig 3
Control Panel Diagram	24VAC: Fig.6 220VAC: Fig.7	24VAC: Fig.6 220VAC: Fig.7	24VAC: Fig.8 220VAC: Fig.9	24VAC: Fig.8 220VAC: Fig.9	24VAC: Fig.8 220VAC: Fig.9	Fig 10

Floating Control Actuator

Type	W-A11A1(2)F	W-A11B1(2)F	W-A11C1(2)F	W-A11D1(2)F	W-A11E1(2)F
Power Voltage	1:24VAC 2:220VAC	1:24VAC 2:220VAC	1:24VAC 2:220VAC	1:24VAC 2:220VAC	1:24VAC 2:220VAC
Power Frequency (Hz)	50±1%	50±1%	50±1%	50±1%	50±1%
Energy Consumption	5.5VA	5.5VA	10VA	10VA	10VA
Rated Actuator Force (N)	500	1000	1800	3000	5000
Actual Actuator Force (N)	500-700	1000-1200	1800-2000	3000-3500	4500-5500
Action Time (s/mm)	3.85	3.85	3.20	3.20	2.70
Stroke (mm)	22	22	42	42	42
IP Grade	IP54	IP54	IP54	IP54	IP54
Input Signal	3-Point	3-Point	3-Point	3-Point	3-Point
Wiring Diagram	Fig.4	Fig.4	Fig.4	Fig.4	Fig.4
Control Panel Diagram	-	-	Fig.11	Fig.11	Fig.11

Wiring and Panel Diagrams of Electric Actuator

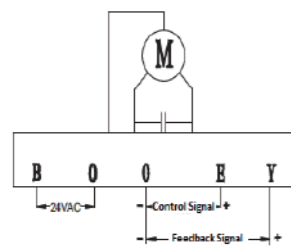

Fig.1: Intelligent Proportional Control Wiring 500/1000/1800/3000/5000N (24VAC)

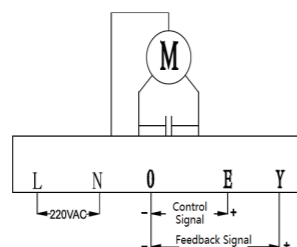

Fig.2: Intelligent Proportional Control Wiring 500/1000/1800/3000/5000N (220VAC)

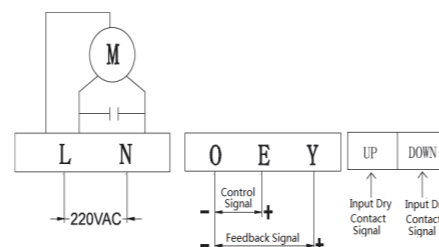

Fig.3: Intelligent Proportional Control Wiring 16000N (220VAC)

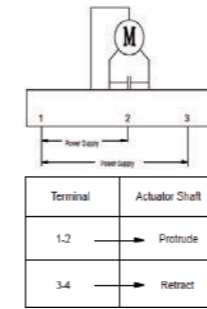

Fig.4: Floating Point Control Wiring 500/1000N

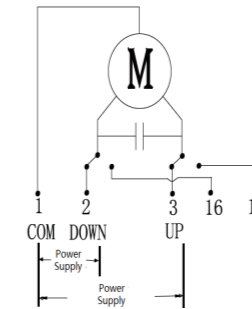

Fig.5: Floating Point Control Wiring 1800/3000/5000N

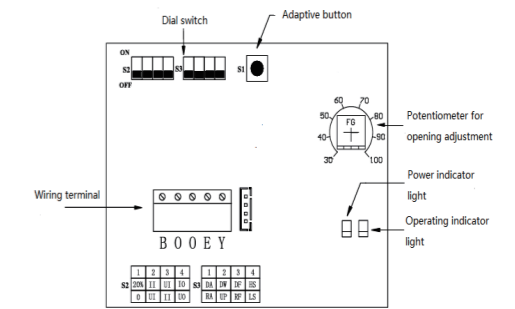

Fig.6: Control Panel - Intelligent Proportional Control 500/1000N (24VAC)

Remark: A. When a voltage is applied between End 1 and End 2, the actuator's shaft moves outwards.
 B. When a voltage is applied between End 1 and End 3, the actuator's shaft moves inwards.
 C. When there is no voltage, the actuator's shaft stays at the current position.
 *It is forbidden to apply voltages between End 1 and End 2, and between End 1 and End 3 simultaneously!

Remark: A. When a voltage is applied between End 1 and End 2, the actuator's shaft moves outwards.
 B. When a voltage is applied between End 1 and End 3, the actuator's shaft moves inwards.
 C. When a voltage is applied between End 1 and End 16, the actuator's shaft moves outwards to its lower limit position, providing active feedback (DF3 Function).
 D. When a voltage is applied between End 1 and End 17, the actuator's shaft moves inwards to its upper limit position, providing active feedback (DF3 Function).
 *It is forbidden to apply voltages between End 1 and End 2, and between End 1 and End 3 simultaneously!

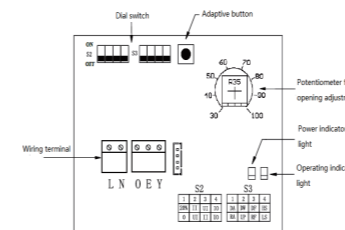

Fig.7: Control Panel - Intelligent Proportional Control 500/1000N (220VAC)

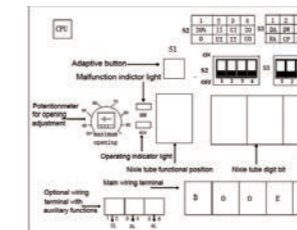

Fig.8: Control Panel - Intelligent Proportional Control 1800/3000/5000N (24VAC)



VAL-KIT-EN-202212

WATTS VAL-KIT

PICV Kit for Fan Coil Units

Series WATTS VAL-Kit is designed for providing optimal hydronic balance in cooling and heating system with variable flow. WATTS PICV controls the flow which avoids both overflowing & efficiency reduction of the unit. WATTS VAL-Kit has a very compact design which includes dynamic flow, pressure and temperature control valves with isolation, flushing, draining and measurement components within a pre-assembled, tested, and ready to install terminal bypass unit.

Features

- Ease & fast insulation and maintenance.
- Very compact design.
- Efficient control of flow, temperature & pressure.
- Actuator options: On/off and modulating
- It can be supplied with flexible hoses & EPP insulation.
- Connection: Threaded ends
- Easy flushing, draining & bypass
- BSRIA tested PICVs.

Pressure –Temperature

- Temperature Range: -10–100 C
- Nominal Pressure: PN20
- Suitable media: Cold/hot water, 50% ethylene glycol

Material

Size	Component	Material	Qty
1	PICV	CW602N	1
2	Strainer	CW602N	1
3	Blue handle	Aluminum	1
4	3-way inlet valve	CW602N	1
5	Bypass	CW602N	1
6	Red handle	Aluminum	1
7	3-way return valve	CW602N	1
8	Insulation	EPP	1

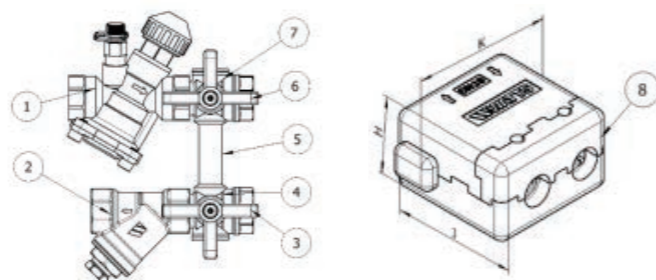

Installation dimensions

DN	DN15	DN20	DN25
A (mm)	128	130	163
B (mm)	102	114	143
C (mm)	80	80	80
D (mm)	77	77	77
E (mm)	105	105	107
F (mm)	183	193	196
G	Internal BSP 1/2"	Internal BSP 3/4"	Internal BSP 1"
H (mm)	110	110	112
J (mm)	142	142	181
K (mm)	194	194	200

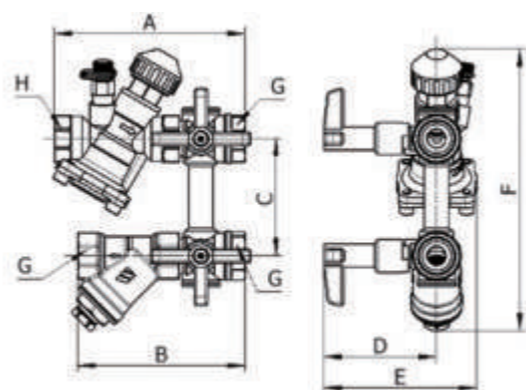

W-STBV-16Q-EN-202206

Flushing

a) Flushing main system:

To perform main flush, adjust the both 3-way valves to open bypass position and start the flushing process. This is performed remove impurities and debris which could affect the correct functioning of the unit.

b) Forward flushing / Normal operation:

We suggest performing forward flushing which is similar to normal operation of the system. During normal operating conditions, both the 3-way valves are adjusted to open position to the operating line thereby closing the bypass line. Strainer is placed on the supply line in order to protect the unit from impurities / debris, and the PICV is placed on the return line in order to regulate the flow through the circuit.

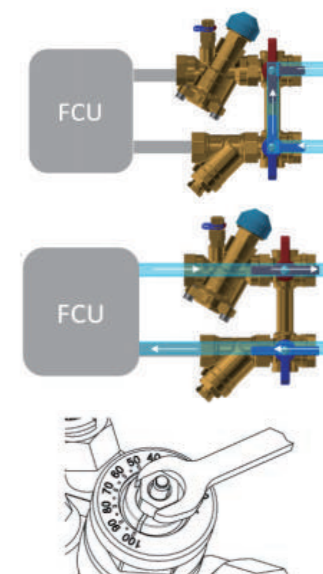

Flow Setting

Through the hexagonal at the top of the valve, 10% to 100% of opening can be preset, with the factory default of 100%. This function can not only meet the needs of special users, but also improve the control accuracy.

Flow rate details

Table of Flow Rate with Preset Opening (m³/h)

Opening/ Size	10%	20%	30%	40%	50%	60%	70%	80%	90%	100%
DN15	0.11	0.21	0.30	0.39	0.47	0.56	0.66	0.76	0.90	1.05
DN20	0.11	0.21	0.30	0.39	0.47	0.56	0.66	0.76	0.90	1.05
DN25	-	0.21	0.31	0.60	0.90	1.20	1.50	1.70	2.10	2.50

Accessories



EPP Insulation



Multiple choice of flexible hoses



ON/OFF electrothermic actuator



Modulating electronic actuator 0-10V - IP54

Wiring drawings for Actuators

On/Off Type

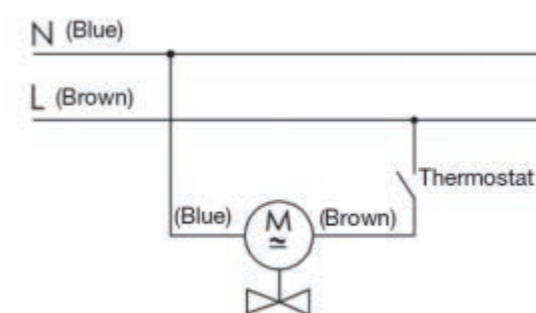

Modulating Type

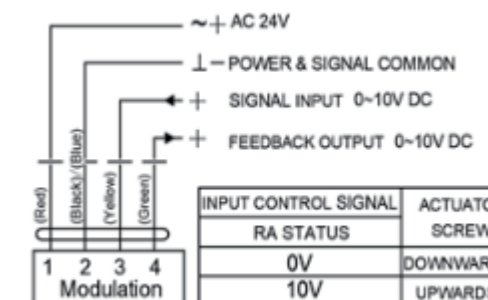



W-SCBV-20T/16Q-EN-202206

W-SCBV-20T Series W-SCBV-16Q Series

Intelligent Control Valve

Size: DN15-DN150

W-SCBV series intelligent control valves serves for fluid control applications such as central air conditioning, heating, water treatment, etc. It is a set of pressure-independent products integrated with energy meter, control ball valve and intelligent actuator.

Features

- Integrated Bluetooth, analog signal, Modbus RTU and BACnet MS/TP control
- Monitoring both on site and remotely
- Integrated multiple control modes
- High protection level

Operating Principles

W-SCBV series intelligent control valve receives standard regulating signals (flow rate, energy, valve position) from DDC or PLC by intelligent actuator, compares the measured value with the target value, after a series of advanced PID algorithm, the valve's opening is adjusted in real-time, the dynamic balance control is realized.

Pressure-Temperature

- Working Pressure: PN20 (DN15-50)
PN16 (DN50-150)
- Temperature Range: 4 C ~95 C

Material

Component	Body	Seat	Ball	Stem	O-Ring
Material	Brass (DN15-50) DI (DN50-150)	PTFE	Brass (DN15-25) Stainless Steel (DN32-150)	Brass (DN15-25) Stainless Steel (DN32-150)	NBR

Product Type

Type	Size	Working Differential Pressure (kPa)	Closing Differential Pressure (kPa)	Flow Range (m³/h)	Cooling Energy(kW)			Heating Energy(kW)	
					ΔT 5K	ΔT 6K	ΔT 7K	ΔT 10K	ΔT 15K
W-SCBV2015S2X-20T	DN15	25-300	600	0.3 ~ 1.0	5.8	7.0	8.1	11.6	17.4
W-SCBV2020S2X-20T	DN20	25-300	600	0.6 ~ 2.1	12.2	14.7	17.1	24.4	36.6
W-SCBV2025S2X-20T	DN25	25-300	600	1.1 ~ 3.5	20.3	24.4	28.5	40.7	61.0
W-SCBV2032S2X-20T	DN32	25-300	600	1.8 ~ 6.0	34.9	41.9	48.8	69.8	104.7
W-SCBV2040S2X-20T	DN40	25-300	600	3.3 ~ 11.0	64.0	76.7	89.5	127.9	191.9
W-SCBV2050S2X-20T	DN50	25-300	600	4.5 ~ 15.0	87.2	104.7	122.1	174.4	261.6
W-SCBV2050S2X-16Q	DN50	25-300	600	5.7 ~ 19.0	110.5	132.6	154.7	220.9	331.4
W-SCBV2065S2X-16Q	DN65	25-300	600	9.8 ~ 32.5	189.0	226.7	264.5	377.9	566.9
W-SCBV2080S2X-16Q	DN80	25-300	600	16.5 ~ 55.0	319.8	383.7	447.7	639.5	959.3
W-SCBV2100S2X-16Q	DN100	25-300	600	24.0 ~ 80.0	465.1	558.1	651.2	930.2	1395.3
W-SCBV2125S2X-16Q	DN125	25-300	600	30.0 ~ 100.0	581.4	697.7	814.0	1162.8	1744.2
W-SCBV2150S2X-16Q	DN150	25-300	600	45.0 ~ 150.0	872.1	1046.5	1220.9	1744.2	2616.3



Specification

- Connection Standard: ISO 228-1, GB/T 7307(DN15-50)
EN 1092-2, GB/T17241.6(DN50-150)
- Closing Differential Pressure: 600KPa
- Leakage Rate: ≤0.01%Kvs
- Power: 24VAC/24VDC
- Protection Level: Actuator IP67
Energy Meter IP65(Thread), IP67(Flange)
- Working Medium: Hot and cold water, ≤50% ethyl/propylene glycol solution

Coding Rules

W	WATTS
SCBV	Intelligent control valve
2	Two-way
Size	
015-DN15:	020-DN20
025-DN25:	032-DN32
040-DN40:	050-DN50
065-DN65:	080-DN80
100-DN100:	125-DN125
150-DN150:	
S2X	50Nm Intelligent Actuator
Valve Working Pressure	20-PN20 16-PN16
Valve Body Material	T:Brass Q:Ductile Iron



W-SCBV-20T/16Q-EN-202206

Installation Dimensions

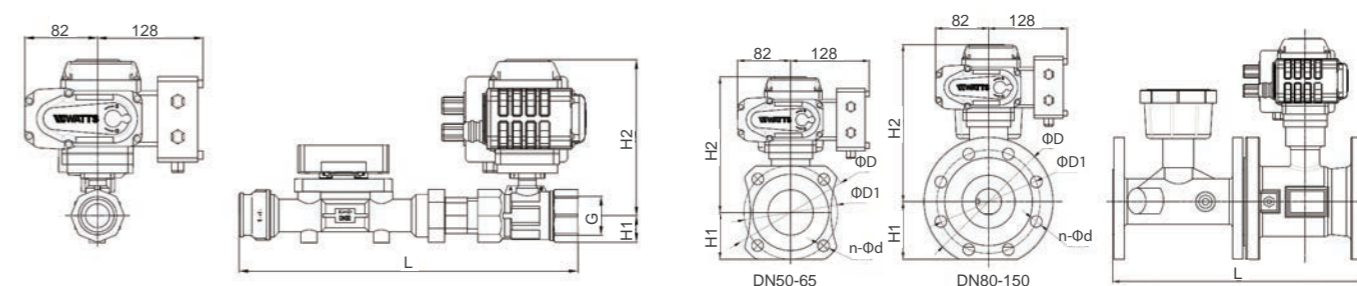

Dimension Size	Thread (G)	L (mm)	H1 (mm)	H2 (mm)
DN15	1/2"	214	16	164
DN 20	3/4"	249	18	169
DN 25	1"	298	21	169
DN 32	1 1/4"	341	25	175
DN 40	1 1/2"	363	30	180
DN 50	2"	355	36	190

Dimension Size	L1 (mm)	H1 (mm)	H2 (mm)	D (mm)	D1 (mm)	n (mm)	d (mm)
DN50	341	65	226	165	125	4	18
DN65	341	75	236	185	145	4	18
DN80	398	92	244	200	160	8	18
DN100	438	101	260	220	180	8	18
DN125	470	120	270	250	210	8	18
DN150	550	141	285	285	240	8	22

Wiring Diagram:

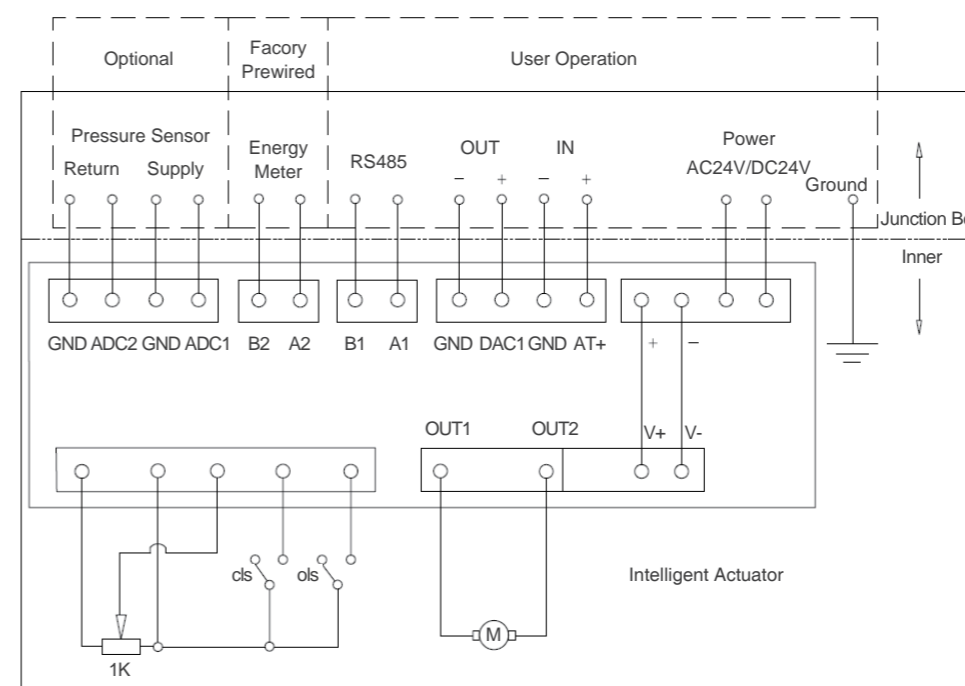



W-WMS-16P/25P-EN-201906

Series W-WMS-16P/25P

Metering Station

Size: DN50-DN600

The series W-WMS metering station is designed for up and down stream measurement.

Features

- Simple structure
- SS304 body

Pressure - Temperature

- Nominal Pressure: PN16 (W-WMS-16P)
PN25 (W-WMS-25P)
- Temperature Range: -10°C ~ 120°C

Material

NO.	Component	Material	Standard
1	Body	Stainless Steel	304
2	Extensions	Stainless Steel	304
3	Test Points	Brass	

Installation Dimensions

W-WMS-16P

Size DN (mm)	DN (mm)													
	50	65	80	100	125	150	200	250	300	350	400	450	500	600
A	18	18	18	18	18	18	18	18	18	21	21	21	21	25
B	105	127	142	162	192	218	273	329	384	444	495	555	617	734
C	148	159	166	176	191	204	232	260	287	317	346	373	404	462

W-WMS-25P

Size DN (mm)	DN (mm)													
	50	65	80	100	125	150	200	250	300	350	400	450	500	600
A	18	18	18	18	18	18	18	18	18	21	21	21	21	25
B	105	127	142	168	194	224	284	340	400	457	514	564	624	731
C	148	159	166	179	192	207	237	265	295	324	352	377	407	461

Characteristic Curve

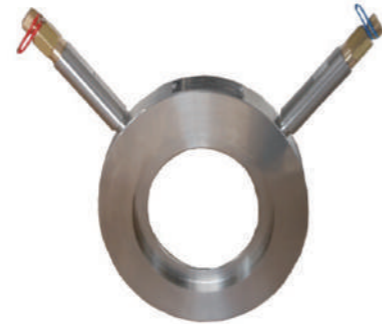
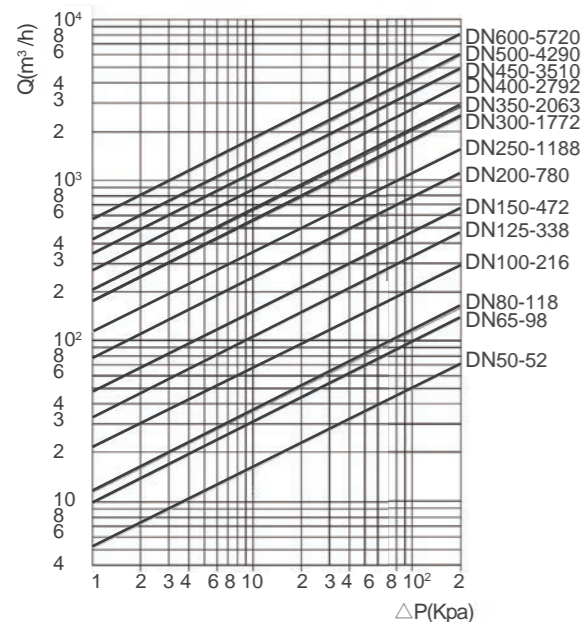

Specification

- Connection Type: Wafer
- Medium: water

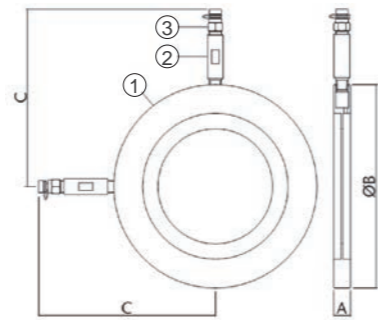

FLU25PL-EN-202206

Series FLU25PL

Flow Switch

Size for pipes: 1"-8"

The FLU25PL Series flow switch is an electromechanical two-stage device (open-closed) for measuring flow rate in DN 1" to DN 8" pipes.

Features

- Plastic case
- Brass fitting
- 3-contact microswitch: 10 (5) A - 230V

Pressure-Temperature

- Nominal Pressure: PN10
- Max Fluid Operating Temperature: 110°C

Material

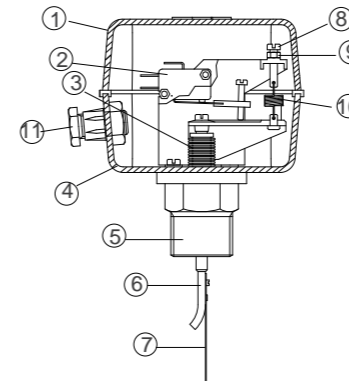

NO.	Component	Material
1	Case cover	Fibreglass-reinforced plastic
2	Microswitch	
3	Phosphor bronze bellows	Phosphor bronze
4	Case base	
5	1" threaded fitting	Brass 1" M
6	Control stem	
7	Paddle	Stainless steel
8	Adjuster screw	
9	Locknut	
10	Return spring	
11	Cable gland	

Technical Specification

Diameter tube inches	Lenght strip mm	Brought m³/h with least regulation (grapevine all screwed) chiude apre		Brought m³/h with least regulation (grapevine all unscrewed) chiude apre	
1"	34	0.9	0.4	2.0	1.5
1" 1/4	34	1.2	0.6	2.6	1.9
1" 1/2	57	1.6	0.9	3.3	2.6
2"	57	3.2	2.3	7.1	5.1
2" 1/2	88	4.2	3.5	8.0	7.0
3"	88	6.3	5.7	12.0	10.5
4"	88	13.5	12.0	28.0	26.0
4"	167	8.0	7.1	20.0	18.0
5"	88	27.0	23.0	60.0	58.0
5"	167	12.1	9.0	30.0	28.0
6"	88	43.0	36.0	91.0	37.0
6"	167	17.2	12.0	35.0	32.0
8"	88	85.0	73.0	176.0	170.0
8"	167	42.0	36.0	90.0	85.0



Application

FLU25PL Series flow switches are equipped with a metal paddle (7) immersed in the fluid. When the flow rate reaches the threshold level, the paddle operates a switch (2) by means of a lever mechanism. The flow switches are supplied with a set of paddle for use with pipes of different diameters. The metal bellows (3) separates the hydronic components from the electrical components, which is housed in a plastic case (1 and 4) with IP64 protection rating. The switch point can be adjusted (between a minimum and a maximum) by turning the setting screw (8). Flow switches are used as protection devices in all applications where fluid needs to flow round a circuit to ensure that the installed devices work properly and are protected against damage. In heating systems with closed expansion vessels, flow switches are used to shut off the flow of heat to the circuit in the event of pump stoppage (as laid down in point R.3.B of the ISPEL "R" regulations).

Specification

- Design Standard: LVD 2014/35/EU

Installation Dimensions

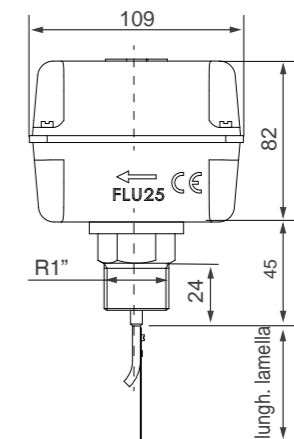



FS-200-W/FS-204-W-EN-202206

Series FS-200-W/FS-204-W

Flow Switch

Size: For pipes 1"-6"

Series FS-200-W and FS-204-W Flow Switches provides accurate monitoring of liquid flow in pipelines servicing water systems, heating systems, air conditioning, and processing installations for industrial and commercial applications. The flow switches are designed to act as an automatic control or safety devices for liquid flow. The single-pole, double-throw switch can be wired to start or stop a motor when a flow or no flow condition exists or to activate an alarm when flow is inadequate. The switch then turns off the alarm when adequate flow is restored.

Features

- EPDM Seal for Superior Performance over Mechanical Bellows
- Universal Design—Replaces Flow Switches by McDonnell Miller, Penn, Taco, Potter and others
- Single Pole Double Throw Switch for Operating Signal Devices, Motors, Alarms, Metering Devices and Heating Units
- Four Heavy Duty Stainless Steel Paddles
- Two 7/8" Electrical Knock-Outs for 1/2" Conduit
- For Use on 1" to 6" Diameter Pipe
- 1" NPT Pipe Connection

Pressure-Temperature

- Nominal Pressure: PN10
- Temperature Range: 0.5°C–121°C

Typical Application

- FS-200-W general purposes
- FS-204-W wet locations

Characteristic Chart

FLOW SPECIFICATIONS										
		Pipe Size								
		1"	1 1/4"	1 1/2"	2"	2 1/2"	3"	4"	5"	6"
Minimum ADJUSTMENT	FLOW INCREASES	4.5	8.1	11.8	16.5	25	33	51	85*	120*
	FLOW DECREASES	2.2	6.8	7.6	9.3	19	22	38	75*	100*
Maximum ADJUSTMENT	FLOW INCREASES	14.8	22.1	25.7	32.3	75	90*	110*	170*	240*
	FLOW DECREASES	13.8	20.1	23.7	30.5	72	85*	100*	155*	220*

*Calculated for various pipe sizes. Flow rates may vary ±10% from values above.



Approval



Material

Component	Material
Enclosure	FS-200-W: NEMA 1-General Purpose FS-204-W: NEMA 4-Wet Locations
Control Chassis Material	FS-200-W: 13 gauge galvanized steel FS-204-W: Anodized cast aluminum
Control Cover Material	FS-200-W: 16 gauge powder coated steel FS-204-W: Powder coated cast aluminum
Contacts	SPDT switch 7.4 FLA, 44.4 LRA @ 120VAC Motor Duty
Pilot Duty Rating	125VA@120/240VAC
Usage	1" to 6" pipe sizes (see Flow Chart)



W-TDV-16Q/25Q-EN-202206

Series W-TDV-16Q/25Q

Constant-flow Multi-Functional Valve

Size: DN50-DN500

This valve can substitute the outlet stop, throttling and check valves, so achieving one valve for multiple purposes. The Watts W-TDV Series multi-functional valves is designed for petroleum, chemical, metallurgical, water treatment and other industries industrial applications.

Features

- An opening indicator showing the opening and closing degree(s) of the valve
- Closing by operating the hand wheel
- Self-sealing measure nipple
- Excellent adjustment performance

Pressure-Temperature

- Nominal Pressure: PN16/PN25
- Temperature Range: -20°C–120°C

Material

Component	Material
Body	Ductile Iron PN16 Duction Iron PN25
Disc	Duction Iron
Stem	Stainless Steel (SS420)
Spring	Stainless Steel (SS304)
Gasket	EPDM
Handwheel	Cast Iron

Installation Dimensions

Size	L(mm)	H1(mm)	H2(mm)	W(mm)		Weight(kg)	
				DN16	DN25	DN16	DN25
DN50	205	267	285	165	165	12.0	12.5
DN65	229	276	294	185	185	15.0	16.0
DN80	250	267	285	200	200	18.0	19.5
DN100	320	319	341	220	235	26.0	28.0
DN125	370	346	377	250	270	35.0	39.0
DN150	415	373	407	285	300	51.0	55.0
DN200	500	582	636	340	360	88.5	92.0
DN250	605	629	693	405	425	121.0	126.0
DN300	725	681	753	460	485	213.0	219.0
DN350	733	717	797	520	555	255.0	264.0
DN400	990	1010	1094	580	620	460.0	469.0
DN450	1000	1025	1138	640	670	535.0	545.0
DN500	1100	1110	1237	715	730	682.0	693.0



Specification

- Test Standard: BS EN 12266-1
- Connection Standard: GB/T 17241.6 EN1092-2
- Connection Type: Flange Type
- Working Medium: Water, glycol

Operating Principles

The body is equipped with a quick closing spring, which adopts the quick-closing principle to prevent water-hammering, protect against medium backflow, and to achieve silent closing. There is an opening indicator, which can be used to adjust the output of the pump by adjusting the opening degree. By closing the stem, medium can be cut off. Therefore, this valve can function as a stop valve.

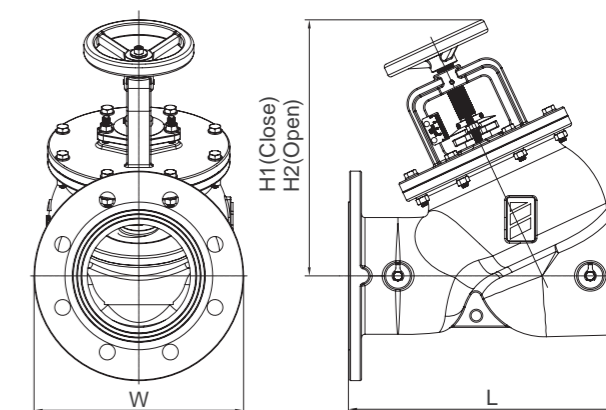



Product Parameters

Type	Size DN	Kvs	Product Code
W-TDV050-16Q	DN50	47.1	616P7054M
W-TDV050-25Q			616P7055M
W-TDV065-16Q			DN65
W-TDV065-25Q	616P7060M		
W-TDV080-16Q	DN80	616P7064M	
W-TDV080-25Q		616P7065M	
W-TDV100-16Q		DN100	616P7069M
W-TDV100-25Q	616P7070M		
W-TDV125-16Q	DN125		616P7074M
W-TDV125-25Q		616P7075M	
W-TDV150-16Q		DN150	616P7079M
W-TDV150-25Q	616P7080M		
W-TDV200-16Q	DN200		616P7084M
W-TDV200-25Q		616P7085M	
W-TDV250-16Q		DN250	616P7089M
W-TDV250-25Q	616P7090M		
W-TDV300-16Q	DN300		616P7094M
W-TDV300-25Q		616P7095M	
W-TDV350-16Q		DN350	616P7099M
W-TDV350-25Q	616P7100M		
W-TDV400-16Q	DN400		616P7120M
W-TDV400-25Q		616P7105M	
W-TDV450-16Q		DN450	616P7125M
W-TDV450-25Q	616P7110M		
W-TDV500-16Q	DN500		616P7130M
W-TDV500-25Q		616P7115M	

Kvs Valve

	DN50	DN65	DN80	DN100	DN125	DN150	DN200	DN250	DN300	DN350	DN400	DN450	DN500
10%	5.3	7.0	5.1	8.5	12.5	33.2	37.0	122.7	91.6	-	-	-	-
20%	10.5	7.8	5.4	14.4	14.4	42.0	46.2	146.6	101.4	120.9	182.4	186.1	255.6
30%	16.7	8.8	5.5	15.6	19.4	50.2	60.8	253.0	117.8	134.9	228.5	262.9	334.6
40%	22.7	10.4	6.1	16.5	28.3	67.8	54.5	392.8	167.5	213.8	314.5	413.2	456.9
50%	30.3	13.0	7.7	17.7	43.6	92.8	125.5	513.8	264.4	366.0	499.1	667.0	652.7
60%	36.5	16.8	10.7	20.5	74.7	134.9	183.7	652.4	389.2	635.3	785.7	1090.7	933.0
70%	41.3	22.5	17.1	26.4	108.1	177.2	271.9	757.3	523.7	942.9	1087.4	1479.7	1381.5
80%	44.3	30.3	25.7	41.3	141.7	225.6	373.7	881.8	721.5	1254.0	1464.1	1947.9	1975.7
90%	46.2	38.9	41.1	61.7	175.4	291.7	480.6	974.3	910.3	1541.7	1814.3	2492.1	2647.0
100%	47.1	48.5	53.5	86.6	219.1	331.4	599.8	1063.9	1133.9	1858.8	2084.1	2967.1	3352.4

Characteristic Curve

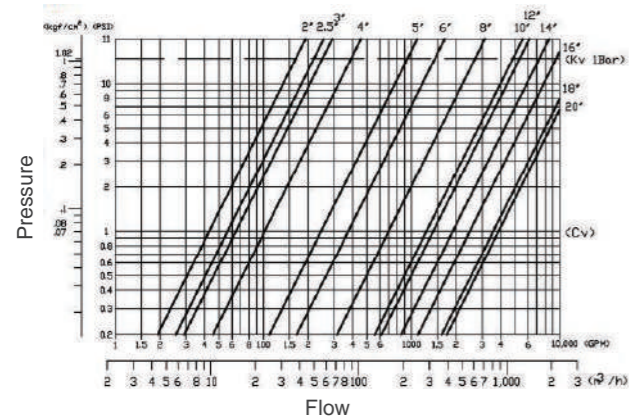

Series 721, 722

Cast Iron & Ductile Iron Flanged End CONTROL CHEK® Valves

Sizes: DN50-DN350

The CONTROL CHEK® valve is designed for installation in pump discharge piping where it performs triple duty. It acts as a spring loaded silent check valve, a shutoff valve, and a balancing valve. Used in conjunction with the Mueller Steam Specialty Suction Diffuser, it constitutes a compact and effective complete pump protection and isolation package.

Features

- Position indicator ensures accurate and repeatable balancing through disc positioning in throttling service
- Stem and yoke are external unwetted parts so are not subject to corrosion or erosion by line fluids. This is a design feature unique to the Mueller Steam Specialty CONTROL CHEK®
- Field servicing is easy and requires no special tools
- NPT drain plug at location "C" is standard. See next page
- Gauge taps are available at both inlet and outlet ends

Pressure - Temperature

PRESSURE/TEMPERATURE-NON-SHOCK		
MODEL	SIZES	RATING CWP
721	2"-12"	200psi @ 150°F 14 bar @ 66°C 165psi @ 300°F
		50psi @ 150°F 10 bar @ 66°C 110psi @ 300°F
722	2" - 12"	640psi @ 100°F 44 bar @ 38°C 565psi @ 300°F
		500psi @ 100°F 34 bar @ 38°C 400psi @ 300°F

Material

	721	722
Body and Yoke	Cast Iron ASTM A126-B	Ductile Iron ASTM A536
Disc	Aluminum Bronze ASTM B148, C952	Aluminum Bronze ASTM B148, C952
Stem	316 SS	316 SS
Seat Guide	Bronze ASTM B584, C844	Bronze ASTM B584, C844
Gland Flange	Cast Iron ASTM A126-B	Cast Iron ASTM A126-B
Packing	Compressed Fiber	Compressed Fiber
Spring	302 Stainless Steel	302 Stainless Steel
Stem Guide	Ductile Iron ASTM A536	Ductile Iron ASTM A536
O-Rings	EPDM	EPDM

Other materials available on request.
*722G grooved end CONTROL CHEK® available. See the LOCXEND® section of the Mueller Steam Specialty Engineering binder.



Models 721, 722

Installation Dimensions

SIZE in.	DIMENSIONS			WEIGHT kgs.
	A(mm)	B(mm)	C(NPT)mm	
721				
2	213	244	15	15
2½"	225	244	15	18
3	254	257	15	27
4	368	321	15	45.4
5	406	321	15	70
6	457	445	20	90
8	546	457	20	159
10	648	552	25	218
12	762	616	25	300
14	772	622	25	359
722				
2	238	244	15	17
2½"	260	244	15	21
3	286	257	15	29
4	397	321	15	54.5
5	422	321	15	78
6	501	445	20	104
8	600	457	20	186
10	711	552	25	250
12	803	616	25	331
14	851	622	25	417

Apply For Certified Drawings.

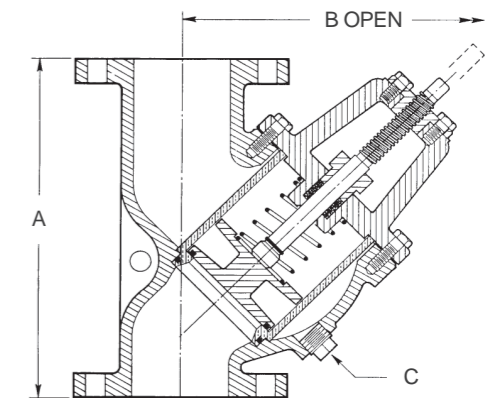

Models 721, 722



Characteristic Curve

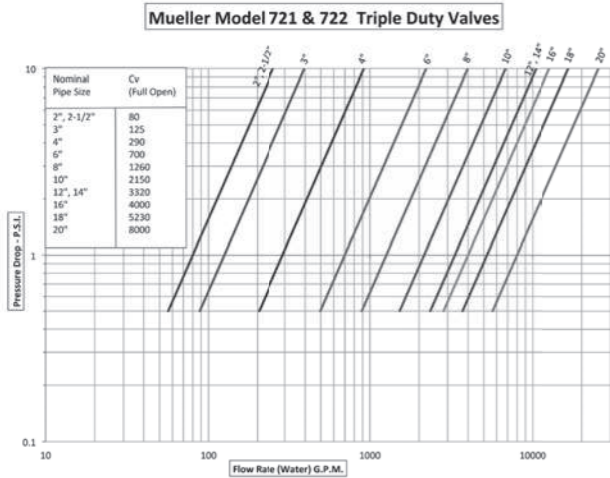

ESTIMATED Cv RATING VS. PERCENTAGE OF STEM RISE

Size	% of STEM RISE								
	100%	90%	80%	70%	60%	50%	40%	30%	20%
2"	80	-	-	-	-	-	-	-	-
2-1/2"	80	-	-	-	-	-	-	-	-
3"	125	120	112	100	88	75	60	46	30
4"	290	278	261	231	204	174	140	106	69
6"	700	670	629	558	492	421	338	255	166
8"	1260	1207	1132	1004	886	758	609	459	299
10"	2150	2059	1931	1713	1512	1294	1039	783	510
12"	3320	3179	2982	2645	2335	1998	1604	1210	788
14"	3320	3179	2982	2645	2335	1998	1604	1210	788
16"	4000	3831	3593	3186	2814	2407	1932	1458	949
18"	5230	5008	4698	4166	3679	3147	2526	1906	1241
20"	8000	7661	7186	6373	5627	4814	3864	2915	1898

Note: For size selection and estimating purposes only. 2" and 2-1/2" - Data not available

Operation

- Disc is spring loaded to close the valve prior to flow reversal, protecting the pump and guarding against water hammer.
- Disc opens at .25psi
- Disc opens a 1/3" for each inch of line size, allowing greater flow than similar products
- Disc is fully guided with external threaded stem.
- Threaded stem allows flow adjustment from bubble tight shut off to full flow.



Series TDV

Triple Duty Valves

Sizes: DN65-DN300

Series TDV Triple Duty Valves are designed for use on single, double, and vertical in-line pump applications. The TDV combines the functions of a positive hand-tight shutoff valve, check valve, and flow control valve into one versatile package, and eliminates the need to utilize three separate valves on the pump system. By using the series TDV, fewer components and fewer connections are required. Therefore, installation time is reduced, less space is needed, and the potential for leaks is reduced: adding up to significant cost savings. The field-convertible design allows the TDV to be changed from the factory-standard, straight pattern to an optional angle pattern by using standard tools, and no additional parts. This allows the TDV to be used as a replacement for angles and elbows, and generates even greater savings on space and connections. The TDV is designed for easy field serviceability with bonnet O-rings that can be replaced under pressure by backseating the valve, and seats that can be changed without the use of special tools.

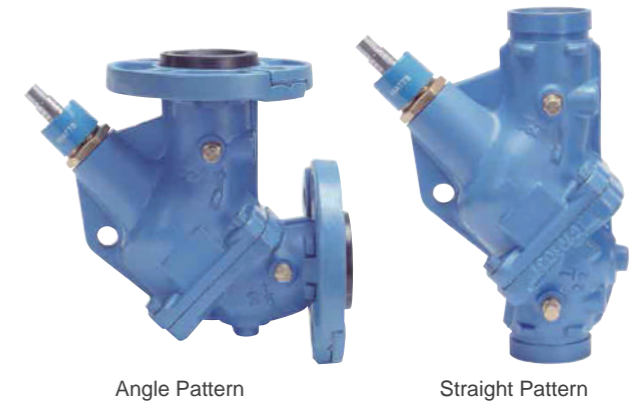

Features

- Reduced field installation and material cost
- Eliminates requirement of three valves on pump discharge
- Soft seat to ensure tight shutoff
- Spring closure design, non-slam silent check valve feature
- Valve Cv designed to ASHRAE flow recommendations for quiet system operation
- Grooved end connections with optional flange adaptors

Pressure-Temperature

- Grooved Ends Only
Maximum Working Pressure: 375psi (26.25 bar)
Maximum Temperature: 230°F (110°C)
- Flange
Maximum Working Pressure: 175psi (12 bar)
Maximum Temperature: 230°F (110°C)

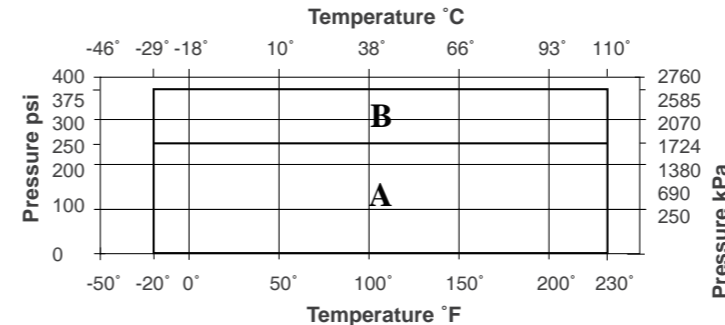

Material

Component	Material
Body	Ductile Iron ASTM A536 GR65-45-12
Disc	Bronze ASTM B584 C-84400
Seat	2 1/2" - 6" Engineered Resin, 8" - 12" EPDM
Stem	Stainless Steel ASTM S582 Type 416
Spring	Stainless Steel ASTM S302
O-rings	Buna-N
Metering Ports	Brass NPT Brass Body with Cap
Drain Tappings (2)	1/4" with Brass plug

Characteristic Curve

Performance Curve with valve in Open Position

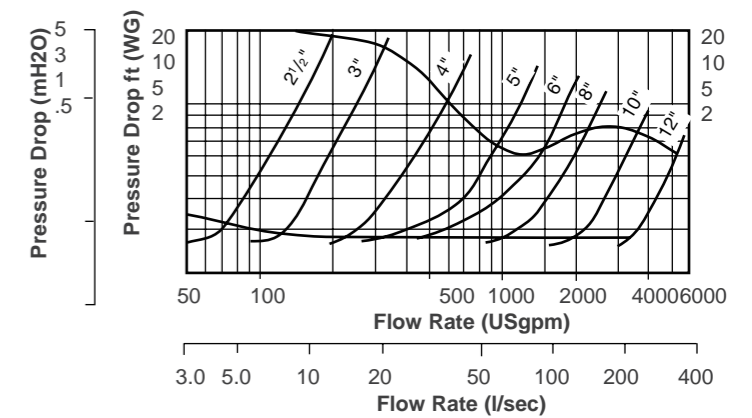

Legend

- A Ductile iron flange adaptors for ANSI 150# flanges
- B Grooved end with 375psi rated pipe coupling

Installation Dimensions

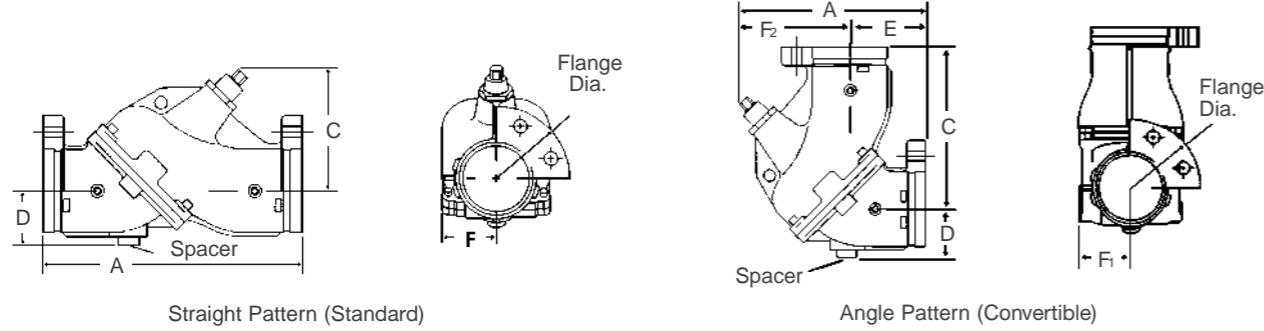

Straight Pattern

SIZE (DN)	DIMENSIONS					FLANGE DIA.	SPACER	WEIGHT
	A	C	D	F	125#			
mm	mm	mm	mm	mm	mm	mm	mm	kgs
65	305	178	70	65	178	25	8.6	
80	305	198	61	76	191	25	10.9	
100	356	203	76	87	235	32	19.0	
125	445	257	92	125	254	32	36.7	
150	526	264	113	149	279	51	54.4	
200	716	579	144	200	343	57	140.6	
250	762	727	167	240	406	57	208.6	
300	967	829	194	321	483	57	394.6	

Angle Pattern (Field Convertible*)

SIZE (DN)	DIMENSIONS						FLANGE DIA.	SPACER	WEIGHT
	A	C	D	E	F1	F2	125#		
mm	mm	mm	mm	mm	mm	mm	mm	mm	kgs
65	295	187	70	117	64	178	178	25	8.6
80	297	213	61	98	76	199	191	25	10.9
100	314	245	76	111	87	200	235	32	19.0
125	397	305	92	140	124	253	254	32	36.7
150	432	359	111	168	149	264	279	50	54.4
200	813	481	145	234	200	580	343	57	140.6
250	975	516	161	248	240	727	406	57	208.6
300	1184	612	194	356	321	825	483	57	394.6

*Series TDV valves are shipped as straight pattern from factory. To convert to angle pattern refer to instruction sheet shipped with valve.

Series W-JZG44-16Q

Water Pump Diffuser

Size: DN50-DN600

The Watts W-JZG44 Water Pump Diffuser is designed to have elbow, strainers and rectifier function at the same time. It's generally used in chemical industry, metallurgy, water treatment, etc.

Features

- Drastically reduce the installation space
- Big filter area, small water resistance
- Special current plate structure, which can eliminate the turbulent flow and reduce cavitation
- Filter screen is removable for cleaning
- Eliminate noise, stabilize water flow and prolong the service life of the pump

Pressure-Temperature

- Maximum Working Pressure: PN16
- Temperature Range: -20°C - 120°C

Material

Component	Material
Body	Ductile Iron+Epoxy Coated
Bonnet	Ductile Iron+Epoxy Coated
Punching Hole Meshes	Stainless Steel 304 (Bore diameter: Ø4mm)
Rayon Mesh	Stainless Steel 304 (The number of mesh:20)

Installation Dimensions

DN1×DN2 DN(mm)	Dimensions (mm)				
	L1	L2	L3	L4	L5
50×50	105	120	168	155	205
65×65	115	125	195	165	220
80×80	130	135	220	185	250
100×80	130	135	220	185	250
100×100	145	185	250	230	330
125×100	145	185	250	230	330
125×125	180	230	300	300	400
150×100	145	185	250	230	330
150×125	180	230	300	300	400
150×150	209	220	349	275	380
200×125	205	220	345	275	380
200×150	205	220	345	275	380
200×200	240	280	410	370	501



Specification

- Test Standard: GB/T 13927-2008
- Connection Standard: GB/T 17241.6-20
- Working Medium: Water

Operating Principles

Water Pump Diffuser is pump diffuser. After medium enters, the inside filter screen can filter out impurities, according to the direction transformation of elbow, current plate can eliminate the turbulent flow and reduce the cavitation.

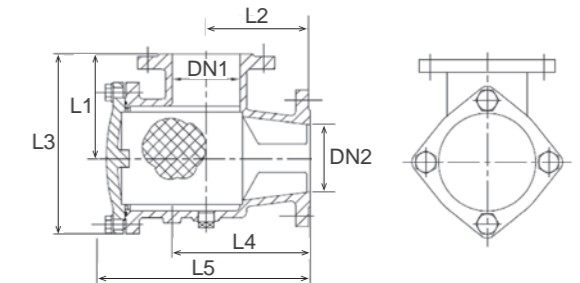

DN1×DN2 DN(mm)	Dimensions (mm)				
	L1	L2	L3	L4	L5
250×200	240	280	410	370	495
250×250	280	325	470	425	615
300×200	280	325	470	425	625
300×250	280	325	470	425	615
300×300	305	380	545	485	682
350×250	305	380	545	485	692
350×300	308	380	548	485	682
350×350	356	420	636	550	785
400×300	320	380	580	480	695
400×350	356	420	636	550	785
400×400	400	450	720	550	830
450×450	430	540	780	680	983
500×500	500	650	900	750	1068
600×600	580	820	1020	900	1357



1011/ 1012-EN-202208

Series 1011, 1012

Suction Diffusers

Mueller Steam Specialty Suction Diffusers provide economical and compact pump protection by straining foreign particles and providing proper flow conditions to the pump. Mounts directly to the suction side of a pump, in either horizontal or vertical position.

Features

- Compact design enables this one unit to act as an elbow, strainer, and entry pipe to the suction side of the pump. This reduces installation time, overall cost, and reduces joint leak paths.
- Equal size flanges or reduced outlet flange sizes available. Reduced outlet design eliminates the need for a reducing base elbow.
- Quick opening knobs allow for quick maintenance. Bolted cover is available on 1012 model.
- O-ring seal eliminates the need to clean the sealing area and install a new flat gasket in competitive models.
- Straightening vanes on the Suction Diffuser's outlet side reduces turbulence into the pump. These minimize stress and erosion within the pump, and eliminate the need for a length of straight pipe to diminish turbulence.
- Robust 5 to 1 Open Area Ratio and blow off feature extend the time between servicing and allows for ease of draining and flushing
- A separate removable fine mesh screen liner is installed in each Diffuser for start-up. After the start-up period, simply remove and discard, leaving the primary screen for operation.
- Special pads fit the I.D. of standard pipe, eliminating the need for pipe saddles and relieving stress on hanger systems.
- Gauge tapping in available as specified with the order

Screens

Model	Sizes	Standard (Water)		Steam Recommendation	
		Material	Opening	Material	Opening
All	1/2" - 4"	304SS	.062 perf	304SS	.033 perf
All	5" and Up	304SS	.125 perf	304SS	.062 perf

Installation Dimensions

Size	Dimensions						Weight			
	Inlet x Outlet mm	A	B	C	D	E	F Screen Removal mm	G NPT	H Pipe Support I.D.	kgs.
1012										
50x50	121	121	176	162	265	351	20	21	14	
65x50	133	135	198	173	283	232	20	35	16	
65x65	135	149	198	175	284	232	20	35	18	
80x50	146	149	224	194	300	244	20	35	26	
80x65	148	149	224	195	302	244	20	35	27	
80x80	149	149	224	197	303	244	20	35	29	
100x80	170	173	265	227	354	292	25	35	36	
100x100	173	173	265	252	341	292	25	35	39	
150x100	211	216	351	275	437	421	25	35	73	
150x125	214	216	351	278	440	421	25	35	75	
150x150	214	216	351	278	440	421	25	35	76	
200x150	240	254	389	303	465	429	25	35	98	
200x200	241	254	425	313	541	581	32	35	144	
250x200	241	298	468	313	541	581	32	35	163	
250x250	298	298	508	375	689	768	32	35	215	
300x250	298	327	537	375	689	838	32	35	237	

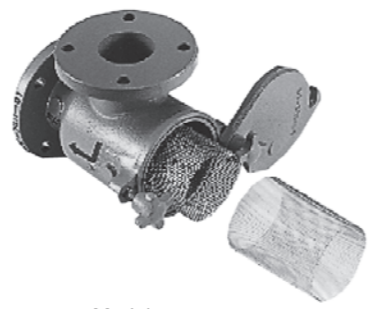

Models 1011, 1012

Size	Dimensions						Weight			
	Inlet x Outlet mm	A	B	C	D	E	F Screen Removal mm	G NPT	H Pipe Support I.D.	kgs.
1011										
50x32	114	114	170	156	259	224	20	21	9	
50x40	114	114	170	156	259	224	20	21	10	
50x50	114	114	170	156	259	224	20	21	10	
65x50	127	127	191	167	276	232	20	27	15	
65x65	127	127	191	167	276	232	20	27	15	
80x50	140	140	214	179	294	244	20	27	20	
80x65	140	140	214	179	294	244	20	27	21	
80x80	140	140	214	179	294	244	20	27	21	
100x80	165	165	260	222	333	292	25	35	44	
100x100	165	165	260	222	333	292	25	35	33	
125x100	191	191	278	254	400	378	25	35	34	
125x125	191	191	278	254	400	378	25	35	46	
150x100	203	203	346	267	429	421	25	35	60	
150x125	203	203	346	267	429	421	25	35	62	
150x150	203	203	346	267	429	421	25	35	63	
200x150	229	229	372	292	454	429	25	35	75	
200x200	229	229	402	298	527	581	32	35	113	
250x200	229	279	453	298	527	581	32	35	125	
250x250	279	279	492	357	670	768	32	53	191	
300x200	229	305	467	298	527	581	32	35	187	
300x250	279	305	518	357	670	838	32	53	223	
300x300	305	305	541	387	665	730	32	53	260	
350x250	279	356	571	357	670	838	32	53	230	
350x300	305	356	594	387	665	787	32	53	273	
350x350	356	356	635	445	711	841	51	53	320	
400x300	305	381	619	387	665	730	32	53	299	
400x350	356	381	660	445	708	787	51	53	340	
400x400	357	357	633	446	706	841	51	53	372	
450x300	305	419	657	387	644	730	32	53	—	

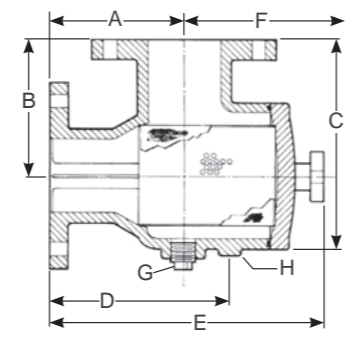

W-STBV-TP-EN-202206

Series W-STBV-TP

Test Points

Size: 1/4"

The Series W-STBV-TP test point is an instrument for pressure and flow measurements. The intended usage is checking and documentation of water flow in heating and cooling constructions.

Features

- Self-sealing measuring points
- Light weight and corrosion resistance
- Simple structure, convenient installation

Pressure - Temperature

- Temperature Range: -10°C ~ 120°C

Material

NO.	Component	Material
1	Body	BRASS-DZR
2	Plug	BRASS-DZR
3	Rubber	EPDM
4	Belt	PP
5	Cap	BRASS
6	Gasket	EPDM

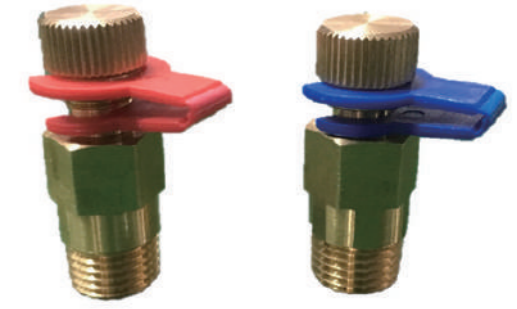
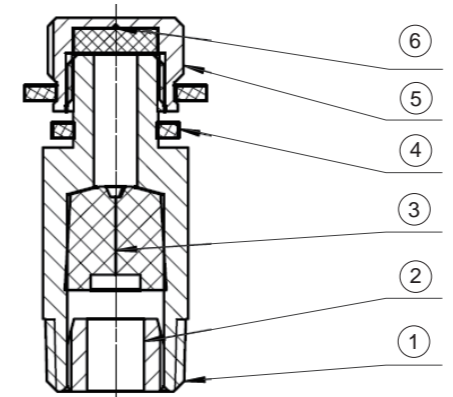

Specification

- Connection Standard: BSPT 1/4 to ISO 7-1-1985
NPT 1/4 to ASME B1.20.1
- Medium: cold and hot water / glycol

Installation Dimensions

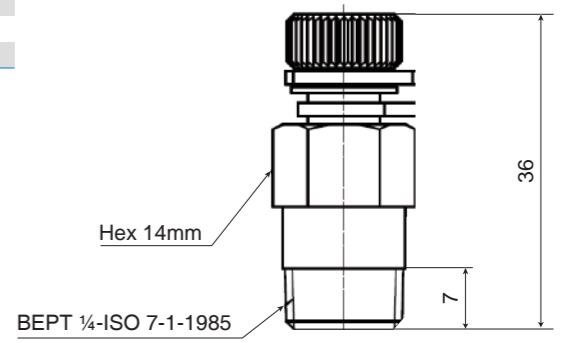



LFTP-202110

Series LFTP

Temperature or Pressure Test Plugs

Sizes: DN6-DN12

Watts LFTP Series allows you to take pressure or temperature readings - quickly - and eliminate the need for leaving costly gauges or temperature recorders on the line. Can be used on various applications of gas, air, water or chemicals to 500psi (34 bar). The LFTP features Lead Free* construction to comply with Lead Free* installation requirements. Recommended maximum temperature ratings of Neoprene is 200°F (93°C), EPDM is 275°F (135°C) and Viton® is 400°F (204°C).

The pressure gauge adapter has a .076 diameter probe of 300 series stainless steel with Lead Free* brass union nut. The probe operates in either 1/4" or 1/2" NPT sizes to accommodate insulated pipe applications.

Features

- Allows quick and efficient temperature or pressure readings
- Eliminates leaving expensive gauges or temperature recorders in line
- Economical means of balancing heating and air conditioning systems
- Eliminates shutting down system for temperature and pressure checks

Pressure-Temperature

- Note: Decal on cap color coded for plug material.
- Neoprene (Blue) Natural gas and petroleum products
Temperature range: -40°F to 200°F (-40°C to 93°C)
- EPDM (White) Hot and cold water service
Temperature range: -40°F to 275°F (-40°C to 135°C)
- Viton® (Green) Hot oil service, chemical resistance.
Temperature range: -10°F to 400°F (-23°C to 204°C)

Note 1: Viton® Test Plugs are not recommended for use with probes larger than .080 diameter or continuous leakage may occur.

Note 2: Maximum temperature for TPG gauges is 185°F.

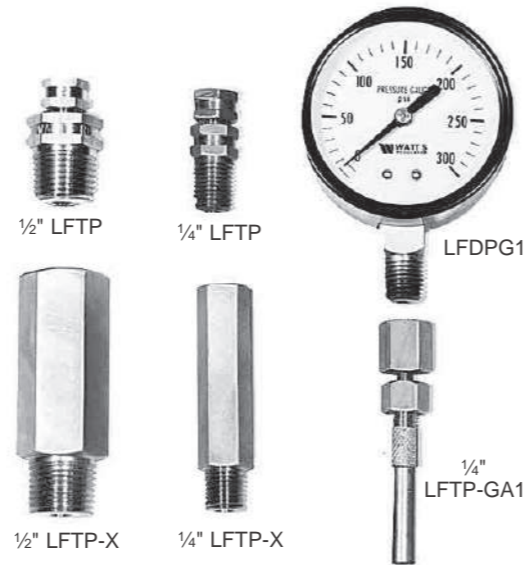

Color Coded
Neoprene- Blue
EPDM - White
Viton® - Green

TEST GAUGE	
Range	Graduation
0-30	1 - 30
0-160	5 - 160
0-300	10 - 300

Installation Dimensions

MODEL	ORDER NO.	SIZE	MATERIAL	MAX. TEMP / PRESSURE	MASTER CARTON NO. / PIECES	WEIGHT (LBS.)
LFTP-N (Neoprene)	0123012	1/4" NPT	Lead Free* Brass	200°F-500psi	180	17
LFTP-E (EPDM)	0123005	1/4" NPT	Lead Free* Brass	275°F-500psi	180	17
LFTP-V (Viton®)	0123008	1/4" NPT	Lead Free* Brass	400°F-500psi	180	17
LFTP-N (Neoprene)	0123013	1/2" NPT	Lead Free* Brass	200°F-500psi	72	14
LFTP-E (EPDM)	0123006	1/2" NPT	Lead Free* Brass	275°F-500psi	72	14
Extensions	0123007	1/4"mx 1/4"f	Lead Free* Brass		90	23
LFTP-X (3")	0123009	1/2"m x 1/2"f	Lead Free* Brass		36	23
Gauges						
LFDPG1-30	0121638	1/4" NPT	Lead Free* Brass Copper bourdon tubesocket	185°F-30psi	40	.06
LFDPG1-160	0121641	1/4" NPT		185°F-160psi	40	.06
LFDPG1-300	0121643	1/4" NPT		185°F-300psi	40	.06
Gauge Adaptors						
LFTP-GA1	0123014	1/4" NPT	Lead Free* Brass Body 300 Series SS Probe		90	23

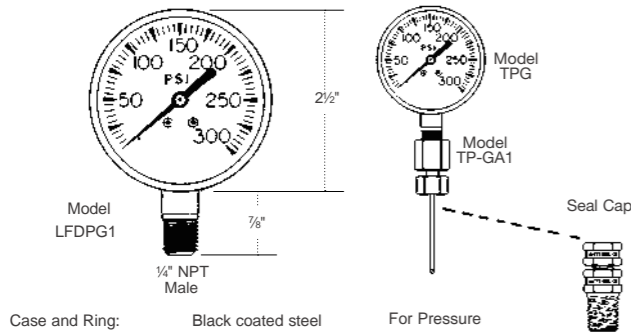

Case and Ring: Black coated steel
Bourdon tube copper
Socket: Lead Free* Brass

For Pressure
Model LFTP

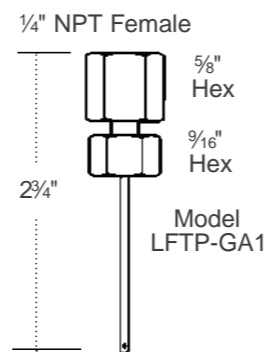
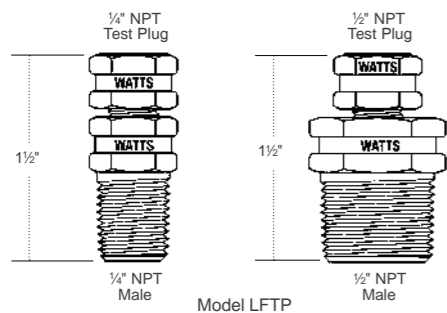

Fittings

- Expansion Joints
- Dielectric Unions

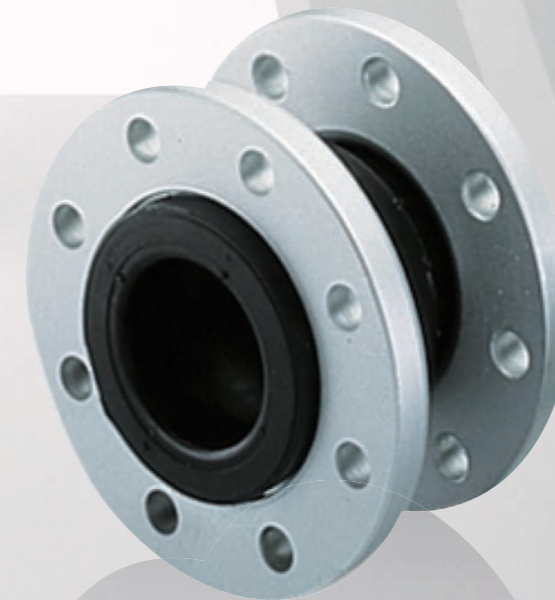



W-ZKB -EN-202212

Series W-ZKB

Flexible Rubber Expansion Joint Single Bellow Flanged Type

Size: DN32-DN600

Mounted on piping installations, the joint can absorb expansions, contractions, oscillations, and vibrations, diminish hammering, reduces noise and prevents electric currents from spreading.

Features

- The multi-level sphere structure, vibration absorbing ability, Good effect of noise reduction
- Can work under high pressure, larger antiknock and elastic situations
- On compression, tensile and torsion deformation can better displacement compensation effect
- 360° rotation of the flange connection, make the installation more convenient and flexible

Pressure - Temperature

- Nominal Pressure: PN10/ PN16
- Temperature Range: -20°C ~ 80°C
- Bursting Pressure: PN48

Test Pressures

Pneumatic	Hydraulic
Shell: 6 bar	Shell: PN10 15 bar PN16 24 bar

Material

Component	Flange	Rubber	
Material	Galvanised carbon steel	EPDM	NBR

Installation Dimensions

Size DN(mm)	H (mm)	L (mm)	(Allowable Displacement)	
			Compression	Extension
32	140	95	9	6
40	150	95	10	6
50	165	105	10	7
65	185	115	13	7
80	200	130	15	8
100	220	135	19	10
125	250	170	19	12
150	285	180	20	12
200	340	205	25	16
250	405	240	25	16
300	460	260	25	16
350	520	265	25	16
400	580	265	25	16
450	640	265	25	16
500	715	265	25	16
600	780	265	25	16



Specification

- Connection Standard: ISO7005-1
EN1092-1
- Test Standard: ISO5208-2008
- Vacuum Degree: 650mmHg
- Deflection Angle: 15°
- Medium: water

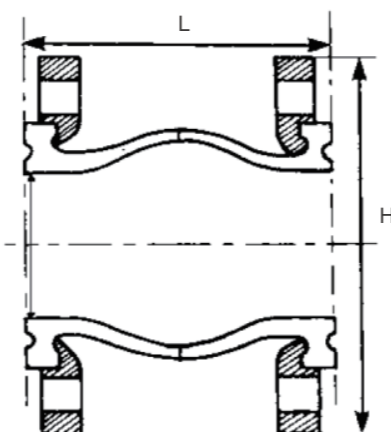

W-ZKT-EN-202212

Series W-ZKT

Flexible Rubber Expansion Joint Double Bellow Union Type

Size: DN20-DN80

Mounted on piping installations, the joint can absorb expansions, contractions, oscillations and vibrations, diminishes hammering, reduces noise and prevents electric currents from spreading.

Features

- The multi-level sphere structure, vibration absorbing ability, good effect of noise reduction
- Can work under high pressure, larger antiknock and elastic situations
- On compression, tensile and torsion deformation can better displacement compensation effect
- 360° rotation of the union and nipple connection, make the installation more convenient and flexible

Pressure - Temperature

- Nominal Pressure: PN10
- Temperature Range: -25°C ~ 120°C

Test Pressures

Pneumatic	Hydraulic
Shell: 6 bar	Shell: 24 bar

Typical Application

- Chilled water and potable water application
- Environmental protection
- Municipal facilities
- Electric power and utilities
- Construction industry

Material

Component	Union nut	Rubber	
Material	Colored Zinc-plated ductile iron	EPDM	NBR

Installation Dimensions

DN	L (mm)	Allowable Displacement	
		Compression	Extension
20	200	22	6
25	200	22	6
32	200	22	6
40	200	22	6
50	200	22	6
65	225	22	6
80	225	22	6



Specification

- Test Standard: ISO5208-2008 or
BS EN12266-2:2002
- Connection Standard: ISO7-1
- Vacuum Degree: 650mmHg
- Deflection Angle: 15°
- Medium: water

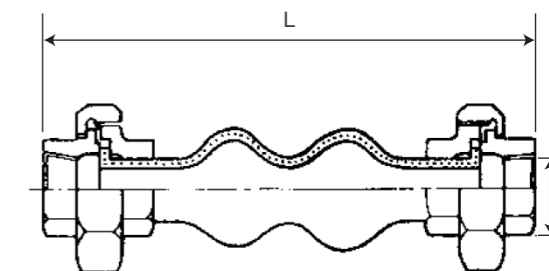



LF4001E-EN-202208

Series LF4001E

Dielectric Unions

Sizes: DN15-DN50

Series LF4001E Dielectric Unions feature a female iron pipe thread to solder connection. Compliant to American Society of Sanitary Engineers ASSE Standard 1079-2005. These unions are designed to be installed between pipe made from dissimilar metals to prevent accelerated corrosion and deterioration in the piping system due to galvanic and stray current.

Features

- Female iron pipe thread to solder connection
- Designed and manufactured to the highest quality standards
- Individually factory certified to withstand a minimum of 600 volts on a dry line with no flashover
- Rated to 180°F (82°C) at 250psi (17.2 bar)

Pressure-Temperature

- Maximum Pressure: 250psi (17.2 bar)
- Maximum Temperature: 180°F (82°C)

Material

Component	Material
Tail Piece	Lead Free Brass
Adapter	Steel
Nut	DN15-DN32: Steel Q215A or Q235A DN40-DN50: Malleable Iron ASTM A197-47
Insulator	Polysulfone
Gasket	EPDM

Installation Dimension

Size		Dimensions				Weight	
		A		B			
in.	mm	in.	mm	in.	mm	ibs.	kgs.
1/2	15	1 5/8	41	1 1/3	44	4.8	136
3/4	20	1 7/8	48	1 7/8	48	6.4	181
1	25	2 3/16	55	2 1/8	54	8.8	249
1 1/4	32	2 5/8	67	2 3/8	60	12.8	363
1 1/2	40	3	76	2 7/16	62	20.8	590
2	50	3 3/4	95	3	76	37.6	1066

† Steel and malleable iron components are zinc plated



Specification

- Complies with Buy America Act (BAA 1933) and The American Recovery and Reinvestment Act (ARRA 2009). Meets American Society of Sanitary Engineers ASSE Standard 1079-2005.

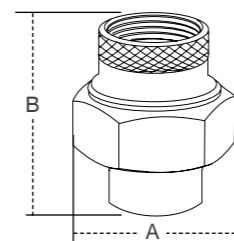

LF3003-EN-202208

Series LF3003

Dielectric Unions

Sizes: DN15-DN50

Series LF3003 dielectric unions feature a female iron pipe thread to female brass pipe thread connections. These unions are designed to be installed between pipe made from dissimilar metals to prevent accelerated corrosion and deterioration in the piping system due to galvanic and stray current. The LF3003 features Lead Free* construction to comply with Lead Free* installation requirements.

Features

- Female iron pipe thread to female brass pipe threaded connections
- Designed and manufactured to the highest quality standards
- Individually factory certified to withstand a minimum of 600 volts on a dry line with no flashover
- Rated to 180°F (82°C) at 250psi (17.2 bar)

Pressure-Temperature

- Maximum Pressure: 250psi (17.2 bar)
- Maximum Temperature: 180°F (82°C)

Material

Component	Material
Tail Piece	Lead Free Brass
Adapter	Steel ASTM A668
Nut	DN15-DN32: Steel Q215A or Q235A DN40-DN50: Malleable Iron ASTM A197-47
Insulator	Polysulfone
Gasket	Buna-N

Installation Dimension

Size		Dimensions				Weight	
		A		B			
in.	mm	in.	mm	in.	mm	ibs.	kgs.
1/2	15	1 5/8	41	2 1/4	57	8	227
3/4	20	1 7/8	48	2 1/4	57	11.4	323
1	25	2 1/4	57	2 1/2	64	16	454
1 1/4	32	2 3/4	70	2 3/4	70	24	680
1 1/2	40	2 1/2	89	2 3/4	70	48	1361
2	50	3 1/8	105	3 1/8	79	69.3	1965

† Steel and malleable iron components are zinc plated



Specification

- Meets federal specifications for tensile strength and thread end connections

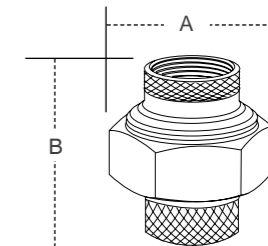



LF3001A-EN-201909

Series LF3001A

Dielectric Unions

Size: DN15-DN50

Series LF3001A dielectric unions feature a female iron pipe thread to solder connection. These unions are designed to be installed between pipe made from dissimilar metals to prevent accelerated corrosion and deterioration in the piping system due to galvanic and stray current. The LF3001A features Lead Free* construction to comply with Lead Free* installation requirements.

Features

- Female iron pipe thread to solder connection
- Designed and manufactured to the highest quality standards
- Factory certified to withstand a minimum of 600 volts on a dry line with no flashover

Pressure-Temperature

- Nominal Pressure: 250 psi (17.2 bar) with standard gasket A, 50 psi (3.4 bar) with optional gasket B
- Maximum Temperature: 82 °C with standard gasket A, 149°C with optional gasket B

Material

Component	Material
Tail Piece	Lead Free Brass
Adapter	Steel ASTM A668
Nut	DN15-DN32: Steel Q215A or Q235A DN40-DN50: Malleable Iron ASTM A197-47
Insulator	Polysulfone P1700 #937 UV black
Gasket	Buna-N

Installation Dimension

Size	Dimensions				Weight	Cv	Kv
	A		B				
in. mm	in.	mm	in.	mm	lbs.	kgs.	
1/2 15	1 1/2	32	1 7/8	48	6	170	26 22.49
3/4 20	1 5/8	41	2 1/8	54	6.7	190	50 43.25
1 25	2 7/8	48	2 1/2	64	9.3	264	94 81.31
1 1/4 32	2 1/4	57	3	76	14.1	400	150 129.75
1 1/2 40	2 3/4	70	3	76	21.8	618	260 224.9
2 50	3 1/2	89	3	76	42.6	1208	480 415.2

† Steel and malleable iron components are zinc plated

** Optional Gasket B (GB)- EPDM Gasket for use in steam or hot water applications up to 300 F (149 C) at 50 psi (3.4 bar).



Specification

- Design Standard: BAA 1933, ARRA 2009
- Connection Standard: Threaded to ANSI B.1.20.1, Solder to ANSI B.16.18
- Test Standard: ASSE 1079

Approval

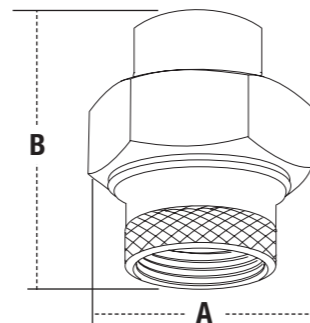

LF3100-EN-201909

Series LF3100

Dielectric Flanged Pipe Fitting

Size: DN65-DN100

LF3100 dielectric unions feature an iron pipe thread by a copper solder joint. These fittings are designed to be installed between pipe made from dissimilar metals to prevent accelerated corrosion and deterioration in the piping system due to galvanic and stray current. The LF3100 features Lead-Free* construction to comply with Lead-Free* installation requirements.

Features

- Iron pipe thread to copper solder joint
- Designed and manufactured to the highest quality standards

Pressure-Temperature

- Nominal Pressure: 175 psi (12.1 bar)
- Maximum Temperature: 82 °C

Material

Component	Material
Adapter Tailpiece	Grey Iron Class 25
Union Tailpiece	Uns C36000
Insulator	Polysulfone, Solvay Udel P-1700, White
Flanged Union Gasket	Nitrile Rubber (Buna "N") 80 Durometer
Adapter	Class 25 Grey Iron
Insulator	Polysulfone P1700 #937 UV Black
Washer	Steel
Hex Head Cap Screw	Carbon Steel
Nut	Steel

Installation Dimension

Size	Dimensions				Weight	Cv	Kv
	A		B				
in.	in.	mm	in.	mm	lbs.	kgs.	
2 1/2	5 7/8	149	4 1/4	108	13	6	750 648.75
3	6 3/4	171	4 1/2	114	16	7	1300 1124.5
4	10 1/8	257	4 3/4	121	34	15.4	2300 1989.5

† Steel and malleable iron components are zinc plated

** Optional Gasket B (GB)- EPDM Gasket for use in steam or hot water applications up to 300 F (149 C) at 50 psi (3.4 bar)..



Specification

- Design Standard: BAA 1933, ARRA 2009
- Connection Standard: Threaded to ANSI B.1.20.1, Solder to ANSI B.16.18, flanged to ANSI B16.1
- Test Standard: ASSE 1079

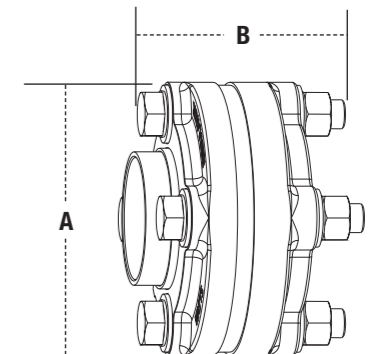

Gauges

- Expansion Joints
- Temperature Gauge



LFDPG-1-EN-202210

Series LFDPG-1

Bottom-Entry Pressure Gauges

Sizes: DN50-DN100

Series LFDPG-1 Bottom-Entry Pressure Gauges are used in commercial, residential, and institutional HVAC applications. These gauges feature ABS polymer cases, Kostil Polymer windows, 1/4" NPT connections, and copper alloy Bourdon tube sensing elements. The LFDPG-1 features Lead Free* construction to comply with Lead Free* installation requirements. Accuracy is ASME, Type B. Series LFDPG-1 gauges are available in various pressure-rating scales. The dual scale features PSI and kPa measurements.

Features

- ABS polymer case
- Kostil polymer window
- Copper alloy Bourdon sensing element
- Tin alloy welding
- 1/4" Lead Free Brass NPT connection
- ASME Type "B" accuracy

Material

Material	Standard
Case	ABS polymer
Window	Kostil polymer
Sensing Element	Copper alloy Bourdon tube
Welding	Tin alloy
Connection	Lead Free Brass

Installation Dimensions

Model	Scale	Size in.	Dimensions			Weight kgs	
			A mm	B mm	C mm		
LFDPG1-2	0 – 15psi	103 kPa	1/4	50	72	28	.09
LFDPG1-2	0 – 60psi	413 kPa	1/4	50	72	28	.09
LFDPG1-2	0 – 100psi	689 kPa	1/4	50	72	28	.09
LFDPG1-2	0 – 160psi	1103 kPa	1/4	50	72	28	.09
LFDPG1-2	0 – 200psi	1379 kPa	1/4	50	72	28	.09
LFDPG1-2 1/2"	0 – 15psi	103 kPa	1/4	63	85	28	.14
LFDPG1-2 1/2"	0 – 30psi	207 kPa	1/4	63	85	28	.14
LFDPG1-2 1/2"	0 – 60psi	413 kPa	1/4	63	85	28	.14
LFDPG1-2 1/2"	0 – 100psi	689 kPa	1/4	63	85	28	.14
LFDPG1-2 1/2"	0 – 160psi	1103 kPa	1/4	63	85	28	.14
LFDPG1-2 1/2"	0 – 200psi	1379 kPa	1/4	63	85	28	.14
LFDPG1-2 1/2"	0 – 300psi	2069 kPa	1/4	63	85	28	.14
LFDPG1-3	0 – 15psi	103 kPa	1/4	80	99	29	.18
LFDPG1-3	0 – 30psi	207 kPa	1/4	80	99	29	.18
LFDPG1-3	0 – 60psi	413 kPa	1/4	80	99	29	.18
LFDPG1-3	0 – 100psi	689 kPa	1/4	80	99	29	.18
LFDPG1-3	0 – 160psi	1103 kPa	1/4	80	99	29	.18
LFDPG1-3	0 – 200psi	1379 kPa	1/4	80	99	29	.18
LFDPG1-3	0 – 300psi	2069 kPa	1/4	80	99	29	.18
LFDPG1-4	0 – 30psi	207 kPa	1/4	100	120	31	.23
LFDPG1-4	0 – 60psi	413 kPa	1/4	100	120	31	.23
LFDPG1-4	0 – 100psi	689 kPa	1/4	100	120	31	.23
LFDPG1-4	0 – 160psi	1103 kPa	1/4	100	120	31	.23
LFDPG1-4	0 – 200psi	1379 kPa	1/4	100	120	31	.23
LFDPG1-4	0 – 300psi	2069 kPa	1/4	100	120	31	.23
LFDPG1-4	0 – 600psi	4137 kPa	1/4	100	120	31	.23



Specification

- ASME B40.100
- EN ISO 9001:2008
- EN ISO 14001:2004

Pressure-Temperature

- Working Temperature: -4°F to 176°F (-20°C to 80°C)

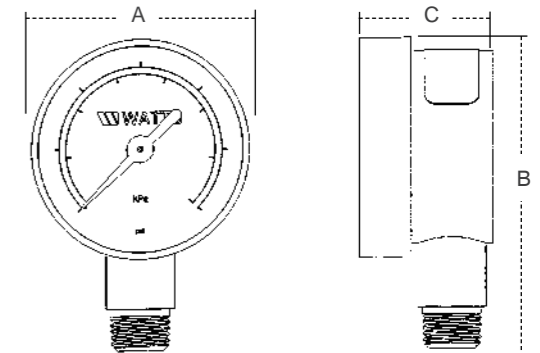

Series LFDPG-5

Top Entry Pressure Gauges

Size: DN50

LFDPG-5 Top-Entry Pressure Gauges are used in commercial, residential, and institutional HVAC applications. The LFDPG-5 features Lead Free* construction to comply with Lead Free* installations requirements. These gauges feature ABS polymer cases, Kostil Polymer windows, 1/8" or 1/4" NPT connections, and copper alloy Bourdon tube sensing elements. Accuracy is ASME, Type B.

Series LFDPG-5 gauges are available in various pressure rating scales. The dual scale features PSI and kPa measurements.

Features

- Kostil polymer window
- Copper alloy Bourdon sensing element
- Tin alloy welding
- 1/8" or 1/4" Lead Free Brass NPT connections
- ASME Type "B" accuracy

Material

Material	Standard
Case	ABS polymer
Window	Kostil polymer
Sensing Element	Copper alloy Bourdon tube
Welding	Tin alloy
Connector	Lead Free Brass

Installation Dimensions

Model	Scale	Size	Dimensions			Weight
			in.	A mm	B mm	
DPG5-2	0 – 160psi / 1103 kPa	1/8	50	68	27	.07
DPG5-2	0 – 160ps / 1103 kPa	1/4	50	71	27	.09



Specification

- ASME B40.100
- EN ISO 9001:2008
- EN ISO 14001:2004

Pressure-Temperature

- Working Temperature: -4°F to 176°F (-20°C to 80°C)

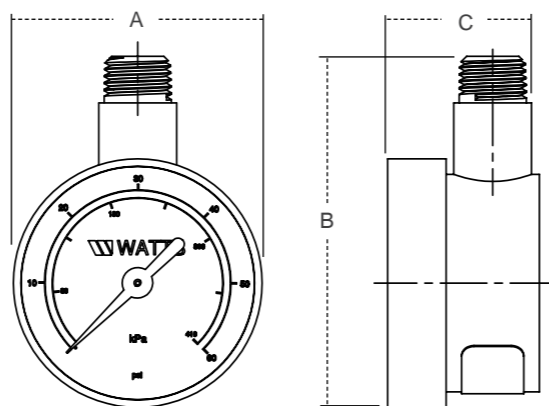

M1-ABS

Bourdon tube pressure gauges

Sizes: DN40-DN100

Bourdon tube pressure gauges M1-ABS Series - brand WATTS - for general industry, gases and liquids not viscous, not aggressive and not crystallising. Dry plastic case DN 40-50-63-80-100 mm bottom entry. Vacuum measures range -1/0, high pressure up to 400 bar. Temperature limits + 60°C, Accuracy class 1.6. Compliant with EN 837-1.

Features

- Design EN 837-1
- Working pressure: Steady: 75% of full scale value
Fluctuating: 60% of full scale value
Short time: full scale value
- Temperature limits: Ambient: -40 ... +60 °C
Medium: +60 °C maximum
Storage: -40 ... +60 °C
- Temperature effect: Deviation from reference temperature (+20°C): ±0,04%/1K of the span
- Accuracy class: Cl 1.6:
- Degree of protection: IP 31 per EN 60 529 / IEC 529
- Individual weight: M1-ABS 40 0.042 kg
M1-ABS 50 0.073 kg
M1-ABS 63 0.089 kg
M1-ABS 80 0.128 kg
M1-ABS 100 0.175 kg

Models

M1-ABS 40

DN40 pressure gauges.

Part No	Pressure Range	Connection	Options*	Box/Master	Min.order
PA1101DELF	-1/0 bar/inHg	R1/8	D+LF+C	240/240	240
PA110117LF	0-1 bar/psi	R1/8	D+LF+C	240/240	240
PA1102DE01	0-1.6 bar/psi	R1/8	D+LF+C	240/240	240
PA120317LF	0-2.5 bar/psi	R1/8	D+LF+C	240/240	10
PA120417LF	0-4 bar/psi	R1/8	D+LF+C	240/240	240
PA120617LF	0-6 bar/psi	R1/8	D+LF+C	240/240	10
PA121017LF	0-10 bar/psi	R1/8	D+LF+C	240/240	10
PA121217LF	0-12 bar/psi	R1/8	D+LF+C	240/240	10
PA121617LF	0-16 bar/psi	R1/8	D+LF+C	240/240	10
PA122017LF	0-20 bar/psi	R1/8	D+LF+C	240/240	10
PA1225DE00	0-25 bar/psi	R1/8	D+C	240/240	240
PA1240DE00	0-40 bar/psi	R1/8	D+C	240/240	240
PA1344DE00	0-60 bar/psi	R1/8	D+C	240/240	240
PA1348DE00	0-100 bar/psi	R1/8	D+C	240/240	240
	0-160 bar/psi	R1/8	D+LF+C	240/240	240
PA1360DE00	0-250 bar/psi	R1/8	D+C	240/240	240
	0-315 bar/psi	R1/8	D+LF+C	240/240	240
	0-400 bar/psi	R1/8	D+LF+C	240/240	240

Material

Material	Standard
Case	Black plastic
Window	Clear plastic
Dial	White plastic
Pointer	Black plastic
Pressure connection	Cu-alloy, 12 mm flats (DN 40) - 14 mm (≥ DN 50) flats
Pressure element	Bourdon tube Cu-alloy, soft soldered ≤ 60 bar C-type, > 60 bar helical type Sn-Ag soldered
Movement	Cu-alloy



M1-ABS 50

DN50 pressure gauges.

Part No	Pressure Range	Connection	Options*	Box/Master	Min.order
PA219918LF	-1/0 bar/inHg	R1/4	D+LF+C	100/100	10
PA210118LF	0-1 bar/psi	R1/4	D+LF+C	100/100	10
	0-1.6 bar/psi	R1/4		100/100	100
PA220318LF	0-2.5 bar/psi	R1/4	D+LF+C	100/100	10
PA220418LF	0-4 bar/psi	R1/4	D+LF+C	100/100	100
PA220618LF	0-6 bar/psi	R1/4	D+LF+C	100/100	10
PA221018LF	0-10 bar/psi	R1/4	D+LF+C	100/100	10
PA221218LF	0-12 bar/psi	R1/4	D+LF+C	100/100	100
PA221618LF	0-16 bar/psi	R1/4	D+LF+C	100/100	10
PA222018LF	0-20 bar/psi	R1/4	D+LF+C	100/100	100
PA222518	0-25 bar/psi	R1/4	D+C	100/100	100
PA224018	0-40 bar/psi	R1/4	D+C	100/100	100
PA220617LF	0-6 bar/psi	R1/8	D+LF+C	100/100	100
PA221017LF	0-10 bar/psi	R1/8	D+LF+C	100/100	100
PA221217LF	0-12 bar/psi	R1/8	D+LF+C	100/100	10
PA2344DF00	0-60 bar/psi	R1/4	D+C	100/100	100
	0-100 bar/psi	R1/4		100/100	100
	0-160 bar/psi	R1/4		100/100	100
	0-250 bar/psi	R1/4		100/100	100
PA2362DF00	0-315 bar/psi	R1/4	D+C	100/100	100
	0-400 bar/psi	R1/4		100/100	100

M1-ABS 63

DN63 pressure gauges.

Part No	Pressure Range	Connection	Options*	Box/Master	Min.order
PA319918LF	-1/0 bar /inHg	R1/4	D+LF+C	100/100	10
PA310118LF	0-1 bar /inHg	R1/4	D+LF+C	100/100	10
PA310218	0-1.6 bar/psi	R1/4	D+C	100/100	100
PA320318LF	0-2.5 bar/psi	R1/4	D+LF+C	100/100	10
PA320418LF	0-4 bar/psi	R1/4	D+LF+C	100/100	10
PA320618LF	0-6 bar/psi	R1/4	D+LF+C	100/100	10
PA321018LF	0-10 bar/psi	R1/4	D+LF+C	100/100	10
PA321218LF	0-12 bar/psi	R1/4	D+LF+C	100/100	10
PA321618LF	0-16 bar/psi	R1/4	D+LF+C	100/100	10
PA322018LF	0-20 bar/psi	R1/4	D+LF+C	100/100	10
PA3225DF00	0-25 bar/psi	R1/4	D+LF+C	100/100	100
PA3240DF00	0-40 bar/psi	R1/4	D+LF+C	100/100	100
PA3344DF00	0-60 bar/psi	R1/4		100/100	100
	0-100 bar/psi	R1/4		100/100	100
	0-160 bar/psi	R1/4		100/100	100
	0-250 bar/psi	R1/4		100/100	100
PA336218	0-315 bar/psi	R1/4	D+C	100/100	100
PA336618	0-400 bar/psi	R1/4	D+C	100/100	100

**M1-ABS 80**

DN80 pressure gauges.

Part No	Pressure Range	Connection	Options*	Box/Master	Min.order
PA4101EC00	-1/0 bar/inHg	G3/8B	D+LF+C	1/50	50
	0-1 bar/psi	G3/8B		1/50	50
	0-1.6 bar/psi	G3/8B		1/50	50
	0-2.5 bar/psi	G3/8B		1/50	50
	0-4 bar/psi	G3/8B		1/50	50
	0-6 bar/psi	G3/8B		1/50	50
PA4210DC01	0-10 bar/psi	G3/8B	D+LF+C	1/50	50
PA4216DC00	0-16 bar/psi	G3/8B	D+LF+C	1/50	50
PA4225DC00	0-25 bar/psi	G3/8B	D+LF+C	1/50	50
	0-40 bar/psi	G3/8B		1/50	50
	0-60 bar/psi	G3/8B		1/50	50
	0-100 bar/psi	G3/8B		1/50	50
	0-160 bar/psi	G3/8B		1/50	50
	0-250 bar/psi	G3/8B		1/50	50
	0-315 bar/psi	G3/8B		1/50	50
	0-400 bar/psi	G3/8B		1/50	50

M1-ABS 100

DN100 pressure gauges.

Part No	Pressure Range	Connection	Options*	Box/Master	Min.order
	-1/0 bar/inHg	G1/2B		1/30	30
PA5101DL00	0-1 bar/psi	G1/2B	D+C	1/30	30
	0-1.6 bar/psi	G1/2B		1/30	30
PA5203DD00	0-2.5 bar/psi	G1/2B	D+C+LF	1/30	30
PA5204DD01	0-4 bar/psi	G1/2B	D+C	1/30	30
PA5206DD00	0-6 bar/psi	G1/2B	D+C+LF	1/30	30
PA5210DD01	0-10 bar/psi	G1/2B	D+C	1/30	30
PA5216DD00	0-16 bar/psi	G1/2B	D+C+LF	1/30	30
PA5225DD00	0-25 bar/psi	G1/2B	D+C+LF	1/30	30
PA5240DD00	0-40 bar/psi	G1/2B	D+C+LF	1/30	30
	0-60 bar/psi	G1/2B		1/30	30
	0-100 bar/psi	G1/2B		1/30	30
	0-160 bar/psi	G1/2B		1/30	30
	0-250 bar/psi	G1/2B		1/30	30
	0-315 bar/psi	G1/2B		1/30	30
	0-400 bar/psi	G1/2B		1/30	30

***Options included**

D = Dual scale bar/psi (black/red)

LF = Fimet Watts logo on the dial

C = Accuracy class 1.6



Installation Dimensions

M1-ABS 40

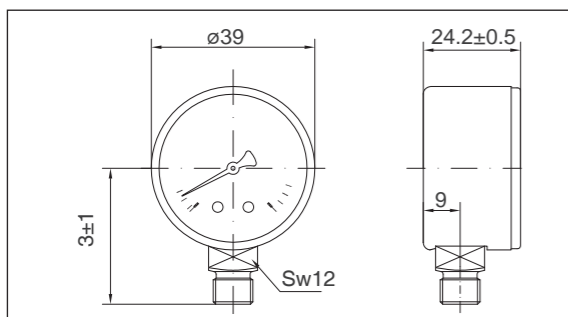

M1-ABS 63

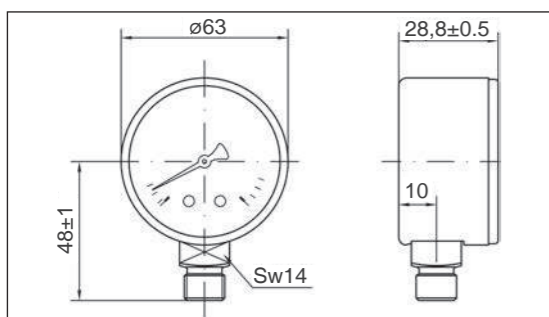

M1-ABS 100

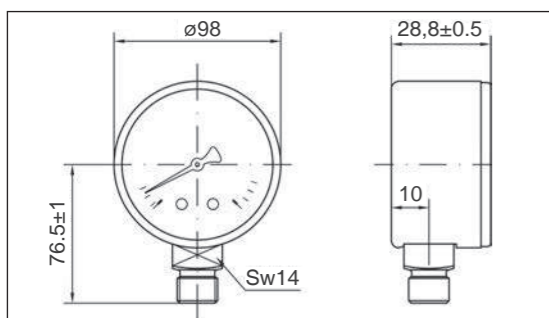

M1-ABS 50

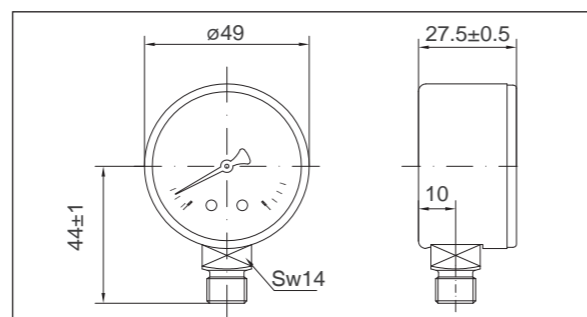

M1-ABS 80

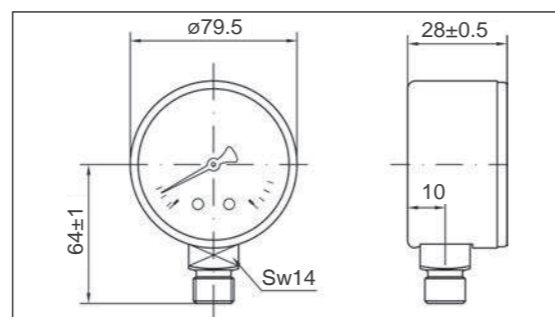

MG1-INOX

Bourdon tube pressure gauges

Sizes: DN50, DN63, DN100

Bourdon tube pressure gauges, MG1-INOX Series, Watts brand, for pneumatic industry, gases and liquids not viscous, not aggressive and not crystallizing. Glycerin filled inox case DN 50-63-100 mm bottom entry. Vacuum measures range -1/0 at high pressure up to 600 bar. Temperature limits +60°C. Accuracy class 1.6. Compliant with EN 837-1.

Features

- Design EN 837-1
- Working pressure: Steady: 75% of full scale value
Fluctuating: 60% of full scale value
Short time: full scale value
- Temperature limits: Ambient: -20 ... +60°C
Medium: +60°C maximum
Storage: -20 ... +60°C
- Temperature effect: Deviation from reference temperature (+20°C): ±0,04%/1K of the span
- Accuracy class: MG1-INOX 50 cl. 2.5
MG1-INOX 63 cl. 1.6
MG1-INOX 100 cl. 1.6
- Degree of protection: IP 65 for EN 60 529 / IEC 529
- Individual weight: MG1-INOX 50 0.130 kg
MG1-INOX 63 0.206 kg
MG1-INOX 100 0.526 kg

Material

Material	MG1-INOX 50	MG1-INOX 63	MG1-INOX 100
Case + roll on bezel	Stainless steel AISI 304 with blow-out device	Stainless steel AISI 304 with blow-out device	Stainless steel AISI 304 with blow-out device
Window	Polycarbonate	Vedril PMMA	Vedril PMMA
Dial	White aluminium	White aluminium	White aluminium
Pointer	Black plastic	Black plastic	Black plastic
Pressure connection	Cu-alloy, 14 mm flats	Cu-alloy, 14 mm flats	Cu-alloy, 21 mm flats
Pressure element	Bourdon tube Cu-alloy, soft soldered ≤ 60 bar C-type, > 60 bar helical type Sn-Ag soldered	Bourdon tube Cu-alloy, soft soldered ≤ 60 bar C-type, > 60 bar helical type Sn-Ag soldered	Bourdon tube Cu-alloy, soft soldered ≤ 60 bar C-type, > 60 bar helical type Sn-Ag soldered
Movement	Cu-alloy	Cu-alloy	Cu-alloy
Liquid filling	Glycerine 99.5%	Glycerine 99.5%	Glycerine 99.5%



MG1-INOX 50



MG1-INOX 63



MG1-INOX 100



MG1-INOX 50
DN50 pressure gauges.

Part No	Pressure Range	Connection	Options*	Box/Master	Min.order
	0-2.5 bar/psi	G1/4B		50/50	100
PZ7M2504DJ00	0-4 bar/psi	G1/4B	D	50/50	100
PZ7M2506DJ00	0-6 bar/psi	G1/4B	D	50/50	100
PZ7M2510DJ01	0-10 bar/psi	G1/4B	D	50/50	100
PZ7M2512DJ00	0-12 bar/psi	G1/4B	D	50/50	100
PZ7M2516DJ01	0-16 bar/psi	G1/4B	D	50/50	100
PZ7M2520DJ00	0-20 bar/psi	G1/4B	D	50/50	100
PZ7M2525DJ01	0-25 bar/psi	G1/4B	D	50/50	100
PZ7M2540DJ00	0-40 bar/psi	G1/4B		50/50	100
	0-60 bar/psi	G1/4B		50/50	100
PZ7M2648DJ00	0-100 bar/psi	G1/4B	D	50/50	100
	0-160 bar/psi	G1/4B		50/50	100
PZ7M2660DJ00	0-250 bar/psi	G1/4B	D	50/50	100
	0-315 bar/psi	G1/4B		50/50	100
	0-400 bar/psi	G1/4B		50/50	100
	0-600 bar/psi	G1/4B		50/50	100

MG1-INOX 63
DN63 pressure gauges.

Part No	Pressure Range	Connection	Options*	Box/Master	Min.order
	-76-0 cm Hg	G1/4B		100/ 100	100
PE309914LF	-1/0 bar/in Hg	G1/4B	D+LF	100/ 100	10
PE3401DJ00	-1/0.6 bar/psi	G1/4B	D	100/ 100	100
PE3502DJ00	-1+1.5 bar/in hg	G1/4B	D	100/ 100	100
PE3504BJ01	-1+3 bar	G1/4B		100/ 100	100
PE308722	-1+5 bar	G1/4B		100/ 100	100
PE3510DJ04	-1+9 bar	G1/4B		100/ 100	100
	-1+15 bar	G1/4B		100/ 100	100
PE340114LF	0-1 bar/psi	G1/4B	D+LF	100/ 100	10
PE340214LF	0-1.6 bar/psi	G1/4B	D+LF	100/ 100	100
PE350314LF	0-2.5 bar/psi	G1/4B	D+LF	100/ 100	10
PE350414LF	0-4 bar/psi	G1/4B	D+LF	100/ 100	10
PE350614LF	0-6 bar/psi	G1/4B	D+LF	100/ 100	10
PE351014LF	0-10 bar/psi	G1/4B	D+LF	100/ 100	10
PE351214LF	0-12 bar/psi	G1/4B	D+LF	100/ 100	10
PE351614LF	0-16 bar/psi	G1/4B	D+LF	100/ 100	10
PE352014LF	0-20 bar/psi	G1/4B	D+LF	100/ 100	10
PE352514LF	0-25 bar/psi	G1/4B	D+LF	100/ 100	10
PE354014LF	0-40 bar/psi	G1/4B	D+LF	100/ 100	10
PE364414LF	0-60 bar/psi	G1/4B	D+LF	100/ 100	10
PE364814LF	0-100 bar/psi	G1/4B	D+LF	100/ 100	10
PE365414LF	0-160 bar/psi	G1/4B	D+LF	100/ 100	10
PE366014LF	0-250 bar/psi	G1/4B	D+LF	100/ 100	10
PE366214LF	0-315 bar/psi	G1/4B	D+LF	100/ 100	10
PE366614LF	0-400 bar/psi	G1/4B	D+LF	100/ 100	10
PE367014LF	0-600 bar/psi	G1/4B	D+LF	100/ 100	10



MG1-INOX 100
DN80 pressure gauges.

Part No	Pressure Range	Connection	Options*	Box/Master	Min.order
	-76-0 cm Hg	G1/2B		1/30	30
PE509916LF	-1/0 bar/in Hg	G1/2B	D+LF	1/30	1
PE5402BL01	-1/0.6 bar	G1/2B		1/30	30
PE5403DL00	-1+1.5 bar/in hg	G1/2B	D	1/30	30
PE5404DL00	-1+3 bar	G1/2B	D	1/30	30
PE5406DL00	-1+5 bar	G1/2B	D+LF	1/30	30
	-1+9 bar	G1/2B		1/30	30
PE5416BL00	-1+15 bar	G1/2B		1/30	30
PE540116LF	0-1 bar/psi	G1/2B	D+LF	1/30	30
PE540216	0-1.6 bar/psi	G1/2B	D	1/30	30
PE550316LF	0-2.5 bar/psi	G1/2B	D+LF	1/30	1
PE550416LF	0-4 bar/psi	G1/2B	D+LF	1/30	1
PE550616LF	0-6 bar/psi	G1/2B	D+LF	1/30	1
PE551016LF	0-10 bar/psi	G1/2B	D+LF	1/30	1
PE551216LF	0-12 bar/psi	G1/2B	D+LF	1/30	1
PE551616LF	0-16 bar/psi	G1/2B	D+LF	1/30	1
PE552016LF	0-20 bar/psi	G1/2B	D+LF	1/30	30
PE552516LF	0-25 bar/psi	G1/2B	D+LF	1/30	1
PE554016LF	0-40 bar/psi	G1/2B	D+LF	1/30	1
PE564416LF	0-60 bar/psi	G1/2B	D+LF	1/30	1
PE564816LF	0-100 bar/psi	G1/2B	D+LF	1/30	1
PE565416LF	0-160 bar/psi	G1/2B	D+LF	1/30	1
PE566016LF	0-250 bar/psi	G1/2B	D+LF	1/30	1
PE566216LF	0-315 bar/psi	G1/2B	D+LF	1/30	30
PE566616LF	0-400 bar/psi	G1/2B	D+LF	1/30	1
PE567016LF	0-600 bar/psi	G1/2B	D+LF	1/30	1

***Options included**
D = Dual scale bar/psi (black/red)
LF = Fimet Watts logo on the dial

Installation Dimensions

MG1-INOX 50

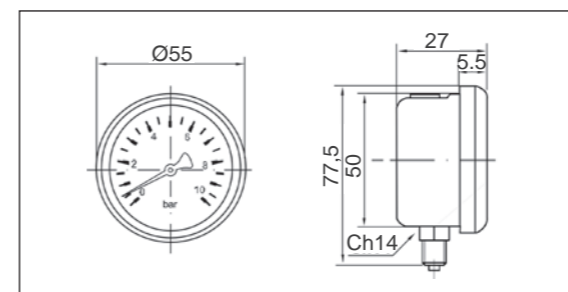

MG1-INOX 63

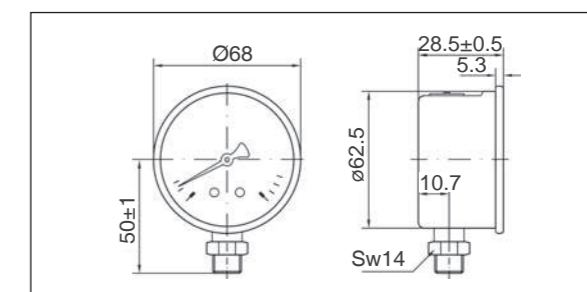

MG1-INOX 100

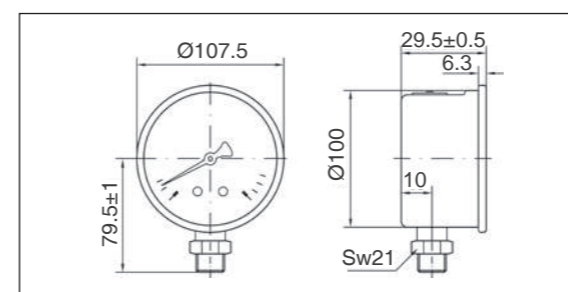



LFTBR-EN-202210

Series LFTBR

Bottom Entry Bimetal Thermometers

Size: DN80

Series LFTBR Bottom-Entry Bimetal Lead Free* Thermometers are used in commercial, residential, and institutional HVAC applications. These thermometers feature chrome steel cases, Kostil polymer windows, Lead Free* brass stems, brass amplifying movements, 1/2" NPT Lead Free* brass snap-in thermowells, and bimetal spiral spring sensing elements. The LFTBR features Lead Free* construction to comply with Lead Free* installation requirements. The Series LFTBR thermometers are available in various temperature rating scales.

Features

- Chrome steel case
- Kostil polymer window
- Lead Free* Brass stem
- Brass amplifying movements
- 1/2" NPT Lead Free* brass snap-in thermowells
- Bimetal spiral spring sensing element

Material

Material	Standard
Case	Chromed steel
Window	Kostil polymer
Stem	Lead Free* Brass
Amplifying Movement	Brass
Thermowell	Lead Free* Brass
Sensing Element	Bimetal spiral spring

Installation Dimensions

Size in.	Model	Scale		Probe Size mm	Dimensions					Weight kgs
		°F	°C		A mm	B mm	C mm	D mm	E mm	
1/2	LFTBR-3-232-248	32 - 248	0-120	51	80	137	51	30	11	.18
1/2	LFTBR-3-332-140	32 - 140	0-60	102	80	186	100	30	11	.36



Specification

ASME B40.100
EN ISO 9001:2008
EN ISO 14001:2004

Pressure-Temperature

- Working Temperature: 32°F to 248°F (0°C to 120°C) or -22°F to 122°F (-30°C to 50°C)

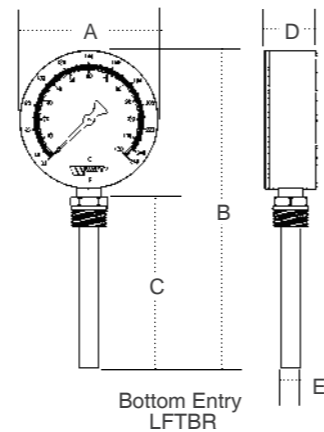

LFTL-EN-202210

Series LFTL

Liquid Fill Angle Thermometers

Size: DN127

Series LFTL Liquid Fill Angle Lead Free* Thermometers are used in commercial, residential, and institutional HVAC applications.

These thermometers are sealed glass tube type models with polypropylene cases, glass lens, non-mercury sensing fluids, and Lead Free* brass thermowells. The LFTL features Lead Free* construction to comply with Lead Free* installation requirements. Accuracy is +/- 2 % of full scale. Series LFTL thermometers are available in various temperature rating scales.

Features

- Polypropylene case
- Glass lens
- Non-Mercury sensing fluids
- Lead Free* brass 1/2" NPT thermowell

Material

Material	Standard
Case	Polypropylene
Lens	Glass
Thermowell	Lead Free* Brass
Sensing Fluid	Non-Mercury bed

Installation Dimensions

Size in.	Model	TEMP. RANGE °F	STEM mm	Dimensions					Weight kgs
				A mm	B mm	C mm	D mm	E mm	
1/2	LFTL-5-2 30-240	30-240	33	34	79	48	21	147	.24



Specification

ASME B40.100
EN ISO 9001:2008
EN ISO 14001:2004

Pressure-Temperature

- Working Temperature Range: 32°F to 932°F (0°C to 500°C)

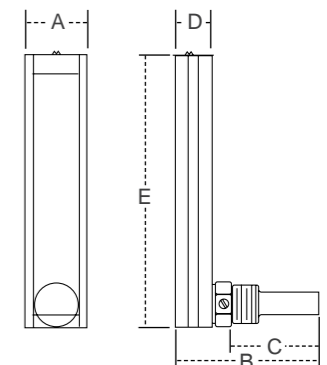



LFTA-EN-202210

Series LFTA

Liquid-Fill, Adjustable Angle Thermometers

Size: DN228

Series LFTA Liquid-Fill, Adjustable Angle Lead Free* Thermometers are used in commercial, residential, and institutional HVAC applications. These thermometers are sealed glass tube type models with a Valox case, glass lens, non-mercury sensing fluids, and a Lead Free* brass thermowell. The LFTA features Lead Free* construction to comply with Lead Free* installation requirements. Accuracy is +/-1 % of full scale. Series LFTA thermometers are available in various temperature rating scales.

Features

- Valox case
- Glass lens
- Non-Mercury sensing fluids
- Lead Free* Brass thermowell

Material

Material	Standard
Case	Valox
Lens	Glass
Thermowell	Lead Free* Brass
Sensing Material	Organic fill

Installation Dimensions

Size in.	Model	Temp. Range °F	STEM mm	Dimensions				Weight kgs
				A mm	B mm	C mm	D mm	
3/4	LFTA-9-3.5 0-12	0-120	89	60	442	144	26	.75
3/4	LFTA-9-3.5 0-160	20-160	89	60	442	144	26	.75
3/4	LFTA-9-3.5 30-240	30-240	89	60	442	144	26	.75



Specification

ASME B40.100
EN ISO 9001:2008
EN ISO 14001:2004

Pressure-Temperature

- Working Temperature Range: From -40°F to 300°F (From -40°C to 148°C)

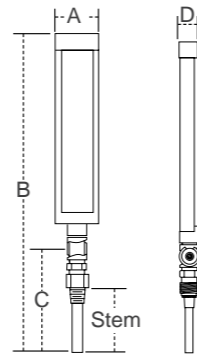

TBR-VE-EN-202210

TBR-VE

Bimetal thermometers

Size: DN80

Bimetal Thermometers Series TBR, Watts brand, for domestic and industrial heating, gases and liquids not viscous, not aggressive and not crystallising. Chrome-plated steel case DN 80 bottom connection. Measures range from 0-60°C up to 120°C / -30+50 °C. Stem Cu-alloy DN 9 with o-ring for clamping 50-75-100 mm. Complete with brass pocket 19 mm flats. Temperature limits as per scale indication. Accuracy class cl. 2.0. Compliant with EN 13190

Features

- Design EN 13190
- Temperature limits: Ambient: -20 ... +60 °C
Medium: as per scale indication
Storage: -20 ... +60 °C
- Operating temperature: As per scale indication
- Temperature effect: Not applicable
- Accuracy class: cl. 2
- Degree of protection: IP 31 for EN 60 529 / IEC 529
- Individual weight: 0.202 kg

Material

Material	Standard
Case	Chrome-plated steel
Window	Clear plastic
Dial	Aluminium white
Pointer	Black plastic
Stem	Cu-alloy Ø 9 mm with O-ring for clamping
Temperature element	Bimetal, spiralled
Movement	Patented cu-alloy-polyester combination
Pocket	Brass, 19 mm flats

Models

TBR-80/VE
DN80 thermometers.

Part No	Stem(mm)	Scale range	Connection	Options*	Box/Master	Min.order
PT8A507006	50	0-120 °C	G1/2B	G+QISP+ORT+VE+LF	1/50	1
PT8A447001	75	-30+50 °C	G1/2B	G+ORT+VE+LF	1/50	1
PT8A447003	75	0-60 °C	G1/2B	G+ORT+VE+LF	1/50	1
PT8B987002	100	-30+50 °C	G1/2B	G+ORT+VE+LF	1/50	1
PT8B447003	100	0-60 °C	G1/2B	G+ORT+VE+LF	1/50	1
PT8B507005	100	0-120 °C	G1/2B	G+QISP+ORT+VE+LF	1/50	1

*Options included

- G = Complete with brass pocket
- VE = European version without chrome-plated ring
- LF = Fimet Watts logo on the dial
- ORT = Stem with O-ring
- QISP = Dial according to INAIL standards



Installation Dimensions

