

Calculation and Selection Result

Calculation and Selection Result

Project 1: Project1

Project Information

Project name	Project1	Project ref	Project1_V1
Country		Date	2023-12-20
City		Client address	
Altitude(m)	0	Client name	

Equipment List

Model	Description	Quantity
CFDAS 058.0 CC2 R4-50	2-Pipe FCU/District Cooling Duct	1

FCU1

Input Information

General Data				
Series	2-Pipe FCU	Electric heater		No
Type	Duct	Fan motor type		AC
Product name	4-Row Duct A4 Duct District Cooling Duct High Static Pressure Duct	Fan speed		Medium
Design according to	Cooling mode	Air flow	L/s	/
Pipe connection direction	Left	ESP	Pa	50
Calculate Type	Fixed Temperature Difference	Cooling capacity	kW	17.00
Antifreeze type	None	Sensible capacity	kW	/
Air volume deviation limit (%)	/	Heating capacity	kW	/
Capacity deviation limit (%)	100			

Specifications CFDAS 058.0 CC2 R4-50 (1)

Unit model					
CFDAS 058.0 CC2 R4-50					
Fan motor data					
Type	Duct		Fan speed		Medium
Quantity	1		Air flow	L/s	705
Power supply	220-240/1/50		ESP	Pa	50
Power input	W	466	Rated current	A	2.13
Cooling					
Inlet air temp (DB/WB)	°C	27.0/19.0	Total capacity	kW	13.68
Outlet air temp (DB/WB)	°C	14.8/13.3	Sensible capacity	kW	10.91
Inlet water temp	°C	5.5	Water flow	L/s	0.36
Outlet water temp	°C	14.5	Water pressure drop	kPa	40.49
Coil Data			Water Pipe Diameter		
Face area	m ²	0.39	Inlet pipe	mm	RCØ19.1
Tube diameter	mm	9.52	Outlet pipe	mm	RCØ19.1
Rows		4	Drain pipe	mm	GØ19.1
Body Dimensions			Panel Dimensions		
Dimension (W*H*D)	mm	1500x340x612	Dimension (W*H*D)	mm	/
Packing size (W*H*D)	mm	1620x380x693	Packing size (W*H*D)	mm	/
Net weight	kg	54.80	Net weight	kg	/
Gross weight	kg	64.60	Gross weight	kg	/
Sound Pressure Level Data			Electrical Heater		
High/Medium/Low	dB(A)	54/52/51	Capacity	kW	/

Note: Sound Pressure Level is tested in a semi-anechoic test room.

Enthalpy-Humidity Chart

humidity chart of cooling

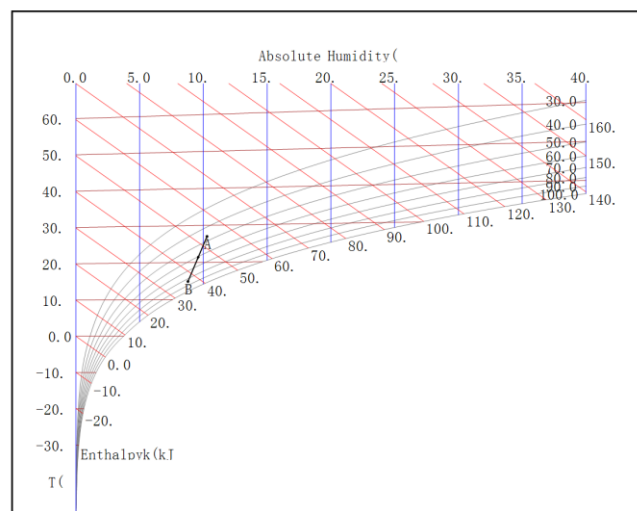

Appearance

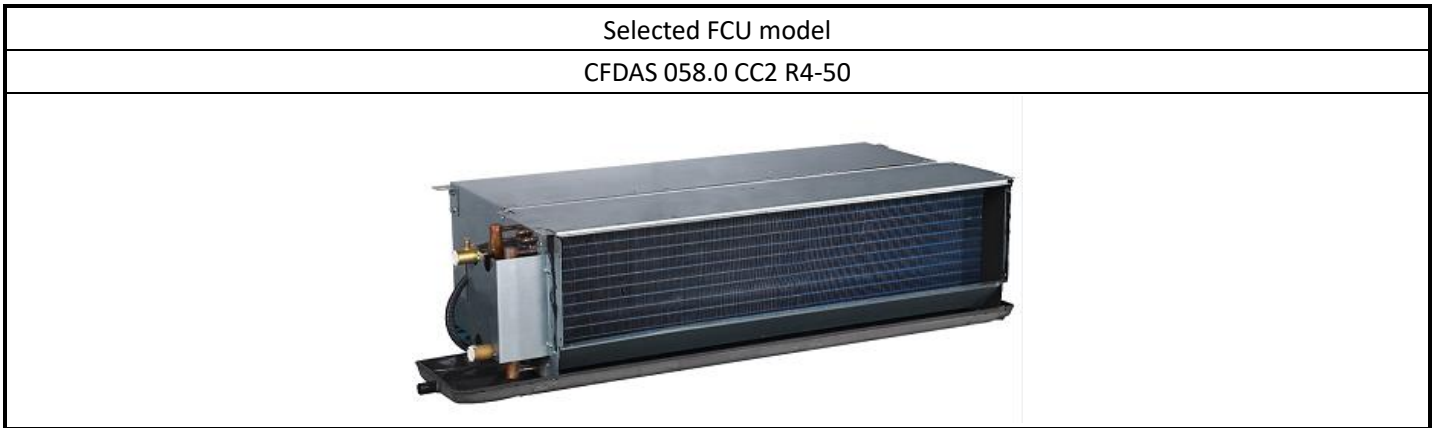

Dimensions

(Unit: mm):CFDAS 058.0 CC2 R4-50

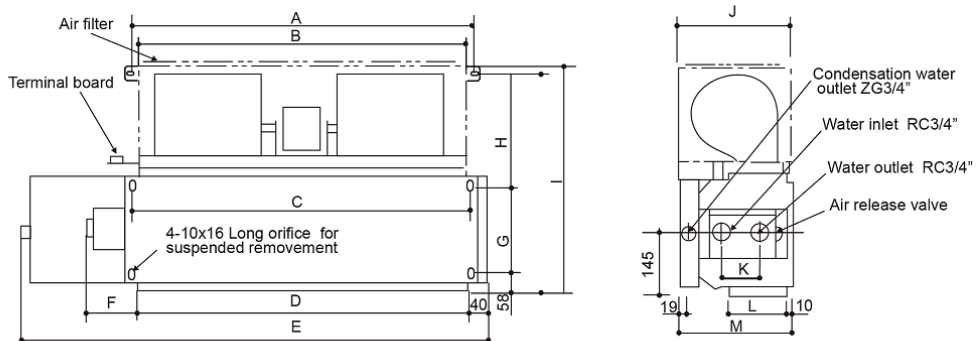

Model Size	800/1000	1200/1400/1500/1600	1800/2000
A	960	1085	1277
B	900	1135	1327
C	910	1112	1308
D	885	1085	1277
E	1180	1369	1500
F	150	160	160
G	195	195	195
H	335	335	335
I	612	612	612
J	342	342	342
K	231	231	231
L	230	230	230
M	340	340	340

Static pressure curve

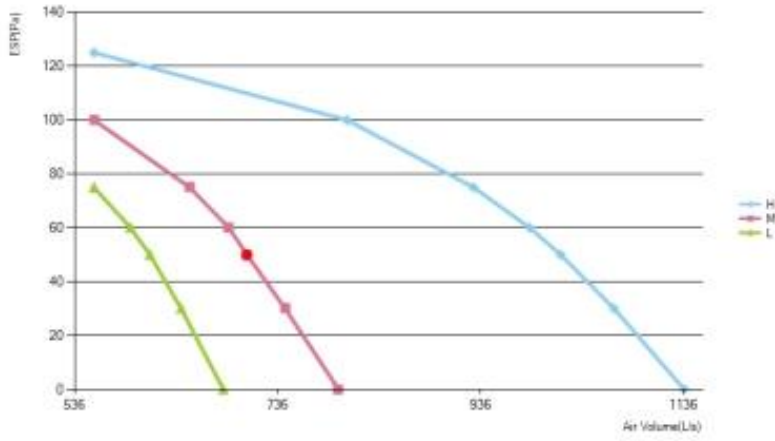

Wiring diagram

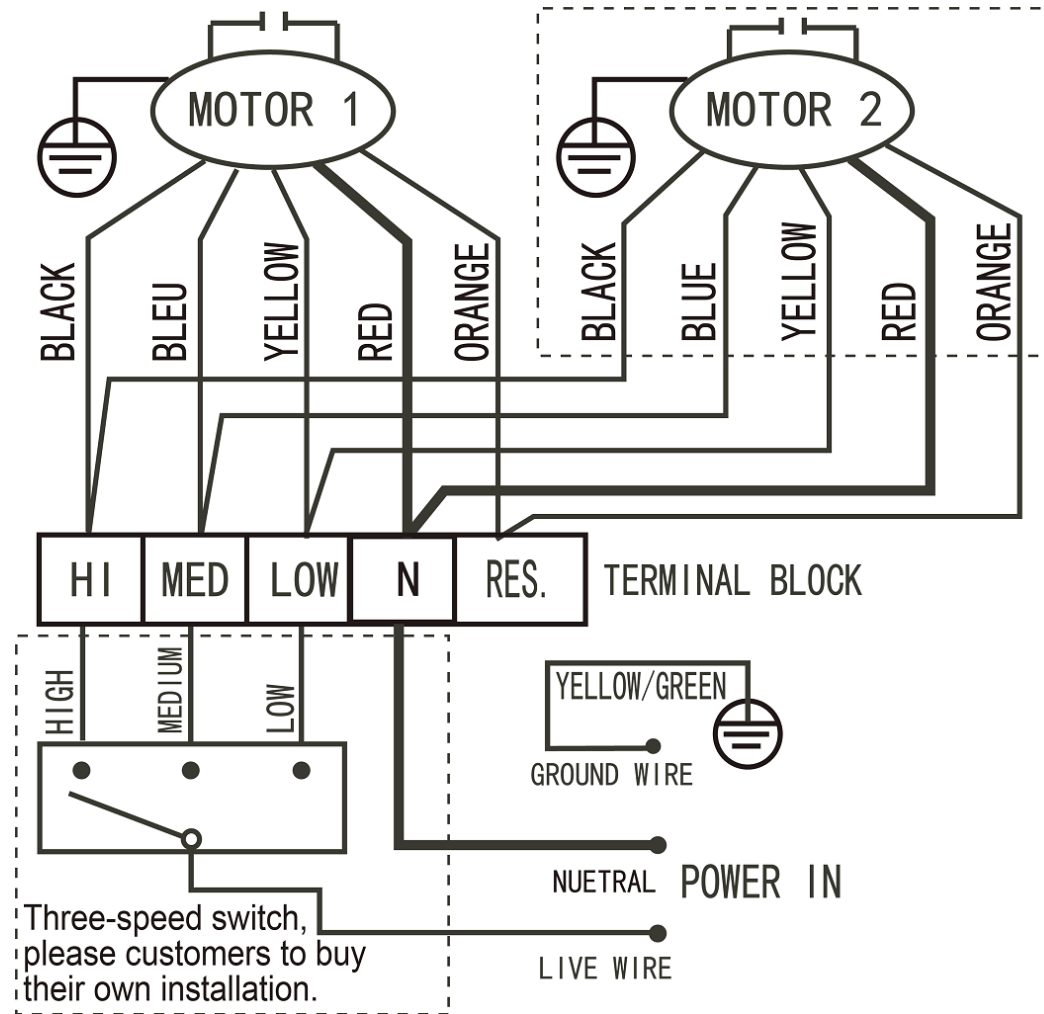

This selection software is provided as a tool to aid project design. Responsibility for product selection remains with the user. Product selection should be based on project requirements and the latest product specifications.